

Golden State
Water Company
A Subsidiary of American States Water Company

Engineering Design Center

Standard Drawings

June 2026



Golden State Water Company Standard Drawings

Table of Contents

PART A – STANDARD DRAWINGS

Section 1 – Pipeline Construction

P-1	Typical Utility Location for new construction
P-2A,B,C	Pipeline Separation Requirements
P-3	Water Pipe Bedding and Trench Backfill
P-4	Trench Repaving
P-5	AC Resurfacing
P-6	Cutting and Plugging Water Mains
P-7	Trench Plates
P-8	6-inch Standard Wet Barrel Fire Hydrant
P-9	6-inch Standard Dry Barrel Fire Hydrant
P-10A	4-inch Flush Out Type 1
P-10B	4-inch Flush Out Type 3
P-11A	4-inch Blow-off Assembly
P-11B	2-inch Blow-off Assembly
P-12	6-inch Flush Out Assembly
P-13	Sampling Station
P-14	1-inch Combination Air Release and Vacuum Relief Valve
P-15	2-inch Combination Air Release and Vacuum Relief Valve
P-16A	1-inch Compact Style Combination Air Release and Vacuum Relief Valve
P-16B	1-inch Compact Style Combination Air Release and Vacuum Relief Valve for Cold Weather Climate
P-17	2-inch Compact Style Combination Air Release and Vacuum Relief Valve
P-18	Standard Thrust Block
P-19	Restraint of Joints for Ductile Iron and PVC Pipe at Tee Connection
P-20	Restraint of Joints for Ductile Iron and PVC Pipe at 90-degree Vertical or Horizontal Bend
P-21	Restraint of Joints for Ductile Iron and PVC Pipe at a Dead End or Each Side of Valve
P-22	Casing for Water Mains
P-23	Tapping Sleeve and Valve
P-24	Cut-in Tee
P-25	Water Service Construction Notes
P-26	1-inch Water Service Connection
P-27	2-inch Water Service Connection
P-28	Typical Meter Box Location
P-29	1-inch Grouped Domestic Service Connection
P-30A,B	Large Meter with Bypass (3-inch to 12-inch Meter)
P-31	Valve Box – Type 1
P-32	Valve Box – Type 3
P-33	Normally Closed Valve Can

P-34A	Pressure Regulating Station (with low flow pressure control valve larger than 3-inches)
P-34B	Pressure Regulating Station (with low flow pressure control valve 2-inches or smaller)
P-35A	Backflow Prevention Assembly for Above Ground Installation (Services 2" or Smaller)
P-35B	Backflow Prevention Assembly for Above Ground Installation (Services 4" or Larger)
P-35C	Backflow Prevention Assembly for 2" Fire Service Installation
P-35D	Metered Fire Hydrant with Backflow Prevention Assembly
P-36	Utility Vault Installation
P-37	Sealing Pipe Opening through Vault
P-38	Insulating Flange Kit Materials
P-39	90-degree Welded Steel Utility Invert
P-40	90-degree Mechanical Joint D.I.P. Utility Invert
P-41	45-degree Welded Steel Utility Invert
P-42	45-degree Mechanical Joint D.I.P. Utility Invert
P-43	Valve Anchor
P-44	2-inch Water Fire Service Connection

Section 2 – Civil and Site Work

C-1	Curb Drain Box
C-2A	Adjustable Pipe Support
C-2B	Adjustable Pipe Support with Restraining U-Bolt and Anchors
C-2C	Adjustable Pipe Support with Restraining U-Bolt on RCP Standpipe
C-3A	Reinforced Concrete Block Wall
C-3B	Retaining Wall for Fire Hydrant and Other Water Appurtenances
C-4A	Steel Tube Fence and Gate
C-4B	Chain Link Fence and Gate
C-5	Typical Site Paving
C-6	Concrete Alley Gutter
C-7	Concrete Curb and Curb & Gutter
C-8	Project Information Sign
C-9	Vehicle Barricade
C-10	Typical Fire Hydrant Location
C-11	Paving Around Valves (Not in the Pavement)
C-12	Pipeline Marker Post Installation
C-13	Pole Mounted Light
C-14	Rumble Pad Construction Entrance-Exit (TC-1B)
C-15	Erosion Control Fiber Roll Installation (SC-5)
C-16A,B	Erosion Control Temporary Gravel Bag Berm Installation
C-17	Concrete Headwall
C-18	Injection Point/Sample Port Protective Cage
C-19A	Local Drainage Structure
C-19B	Local Drainage Pit & Lid Stack Assembly
C-19C	Local Drainage Pit Typical Seepage Pit Plan
C-20A,B,C	Aluminum Tower Antenna & Grounding, Antenna Pole & Grounding, & Base Footing Detail
C-21	Drain Pipe Clean-out Detail

PART B – FACILITY DESIGN DRAWINGS

Section 3 – Pump Stations

PS-1	Typical Booster Pump Station Site Plan and Dimensions
PS-2A,B	Standard Pump Station Floor Plan and Piping Plan
PS-3A	Typical Pump Station Pump and Piping Sections
PS-3B	Typical Pump Station Pressure Relief Riser Section
PS-3C	Typical Pump Station Single Meter Riser Section
PS-3D	Front View Pump and Piping Section
PS-3E	Typical Pump Station Building and Piping Section
PS-4	Typical Pump Can Construction
PS-5	Slab, Footing, and Foundation Section & Details
PS-6	Pressure Switch / Transmitter and Gauge Assembly Detail
PS-7	1" Combination Air Release and Vacuum Relief Valve Assembly
PS-8	2" Combination Air Release and Vacuum Relief Valve Assembly
PS-9	1" Combination Air Release and Vacuum Relief Valve Assembly for Pump Barrel
PS-10A,B	Pump Canopy Plan & Details
PS-11A,B	Architectural Views of Pump Building
PS-12	Top Plate Splice
PS-13	Horizontal Roof Diaphragm Nailing
PS-14A,B,C	Roof Framing Details
PS-15	Pump Station Air Flow
PS-16A	4' Square Skylight and Enclosure
PS-16B	2'-6" x 3'-0" Opening Skylight and Enclosure
PS-17A,B	Concrete Pump Base Pedestal in Dirt or AC Pavement & Concrete Floor Slab Details

Section 4 – Wells

W-1	Water Well Destruction
W-2	Typical Well Site Plan and Dimensions
W-3	Typical Well Construction Cross Section
W-4A	Well Pump Base and Pump Connection (Up to 1,000 GPM)
W-4B	Well Pump Base and Pump Connection (Greater than 1,000 GPM)
W-5A,B,C,D	Well Discharge Pipe and Flush Pipe
W-6	Water Quality Sampling and Air Release & Vacuum Valve Assembly
W-7	Pressure Gage and Water Quality Sampling Port
W-8A	Chemical Injection Quill and Hose Bib
W-8B	Chemical Injection Quill Support
W-9A	Emergency Eye Wash and Shower
W-9B	Chemical Building Work Table
W-9C	Chlorine Analyzer
W-10A	New Well Floor Plan
W-10B	Slab Footing Foundation Detail with Subbase and Soils Preparation
W-11	Acoustic Well Pump Enclosure
W-12A,B	Floor Plan / Architectural Views of Disinfection Building – 1 Bay

W-13A,B	Floor Plan / Architectural Views of Disinfection Building – 2 Bay
W-14A,B	Floor Plan / Architectural Views of Disinfection Building – 3 Bay
W-15A,B	Floor Plan / Architectural Views of Disinfection Building – 4 Bay
W-16A,B	Floor Plan & Architectural Views of Fluoride Injection Building
W-17	Slab Foundation and Structural Details
W-18	Chemical Building Door and Louver Details
W-19A,B,C	Chemical Building Signage, Usage Notes, & Hazardous Material Notes
W-20A,B,C	Floor Plan & Architectural Views Well Building with Removable Roof and Walls
W-21A,B,C,D	Floor Plan & Architectural Views Precast Concrete Disinfection Building

Section 5 – Water Tanks

T-1A	Welded Steel Reservoir Typical Site Plan
T-1B	Welded Steel Reservoir Typical Section View
T-1C	Shell Reinforcing Plate
T-2A	Inlet Connection
T-2B	Inlet Connection Knuckle Roof Tank
T-2C	Inlet Connection Flat Roof Tank and Miscellaneous Details
T-3A,B	Outlet Connection
T-4	Overflow Pipe
T-5	Large Access Manway with Cleanout
T-6	Overflow & Cleanout Catch Basin and Support Bracket
T-7	36-inch Access Way and Section
T-8	Stairway and Anti-Climb Cage
T-9	Tank Roof Working Area
T-10	Roof Hatch and Interior Ladder
T-11	Interior Ladder Safety Post
T-12	Sealed Flanged Roof Hatch
T-13	Center Roof Vent
T-14	Tank Roof CP Hand Hole Cover
T-15A,B	Water Sampling Connection and Sensing Line Connection & Tank Multiple Sample Ports
T-16	Half Height Water Level Indicator
T-17	Altitude Valve and Vault
T-18	Altitude Vault Ladder Tie-down Detail
T-19A,B	Example & Blank of Typical Tank Survey Appurtenance Locations

Part A – Standard Drawings

Section 1

Pipeline Construction

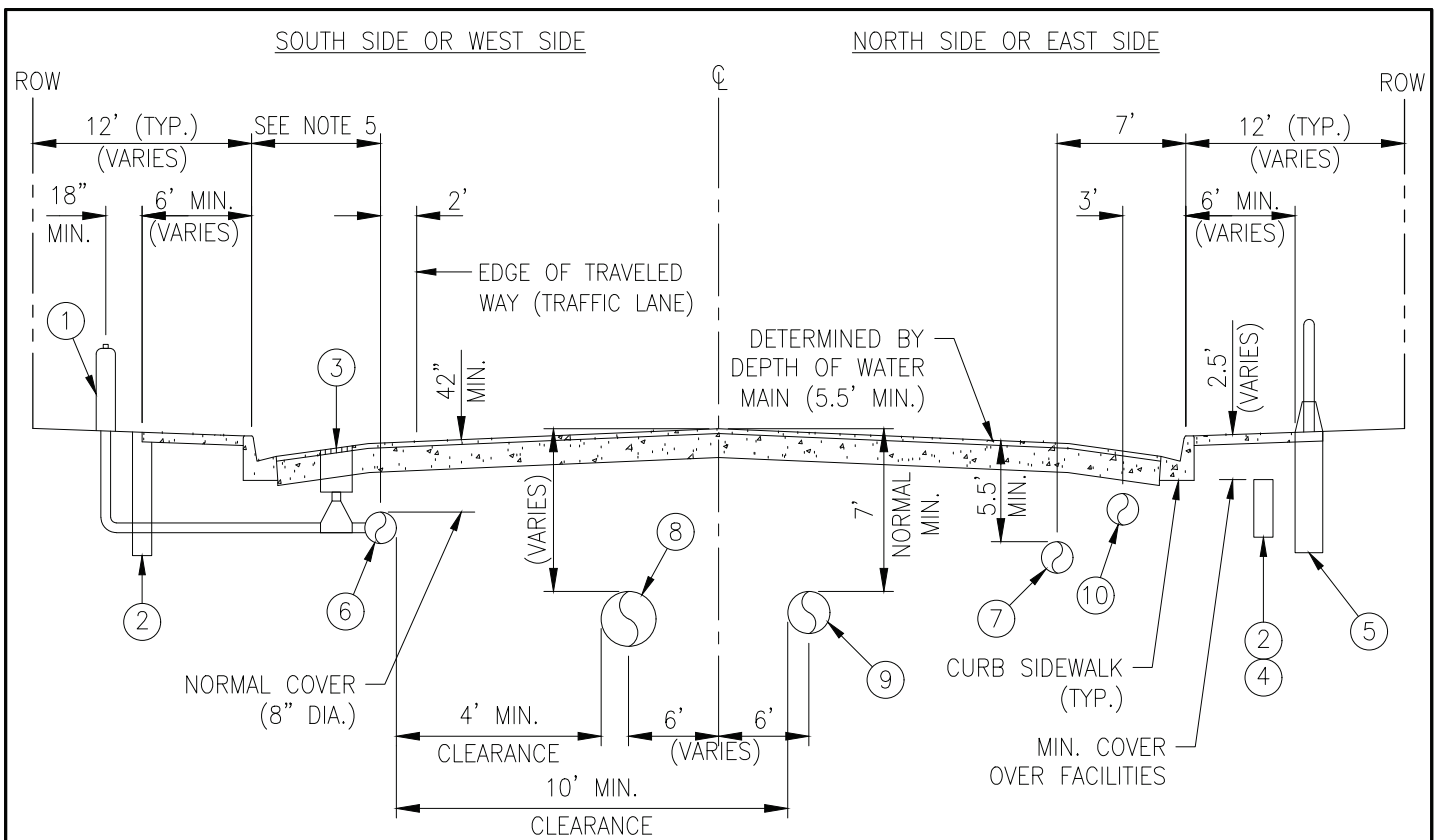

ITEM	DESCRIPTION
①	Fire hydrant, locate in accordance with GSWC Std. Dwg. No. C-10
②	Joint utilities trench
③	Valve box
④	Street lighting conduit in trench
⑤	Street light base
⑥	Domestic water main
⑦	Reclaimed water main (where required)
⑧	Storm drain
⑨	Sewer main
⑩	Gas main

NOTES:

1. Location and depth of existing and proposed utilities must be provided by the developer and shown on any plans submitted to the City/County Public Works Department for approval.
2. Changes may be permitted by GSWC in cases of conflicting facilities.
3. For commercial sidewalks, the fire hydrant shall be placed 18" behind sidewalk. Hydrants shall not be located in sidewalks.
4. Materials shall be selected from the GSWC Approved Materials List.
5. Distance from curb face to water main is 4' min. for 8" pipe and 5' min. for 12" pipe or larger in residential/commercial developments in streets up to 40' curb to curb. Distance can be 7' in major streets greater than 40' wide.

APPROVED BY:
GSWC STANDARDS COMMITTEE

Alison Sweet

EDC MANAGER

6/15/26
DATE



Golden State
Water Company

A Subsidiary of American States Water Company

TITLE:

TYPICAL UTILITY LOCATION
FOR NEW CONSTRUCTION

SCALE:
NONE

DATE:
11/01/25

REV
2026

STANDARD DWG NO.
P-1

CASE A

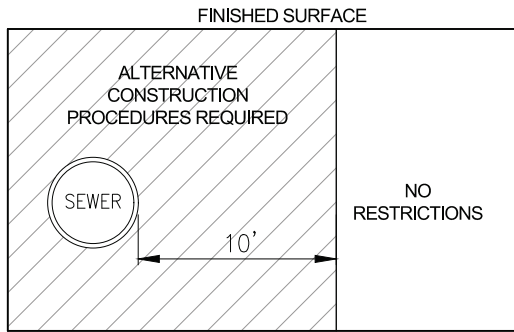

PARALLEL CONSTRUCTION REQUIREMENTS NEAR SEWERS

NOTES:

1. New water mains shall not be installed in the same trench and shall be at least 10 feet horizontally from and 1 foot vertically above any parallel pipeline conveying:
 - a. untreated sewage
 - b. primary or secondary treated sewage
 - c. disinfected secondary recycled water
 - d. hazardous fluids such as fuels, industrial wastes and wastewater sludge
2. Use professional judgement to propose construction that is protective of public health.

CASE B

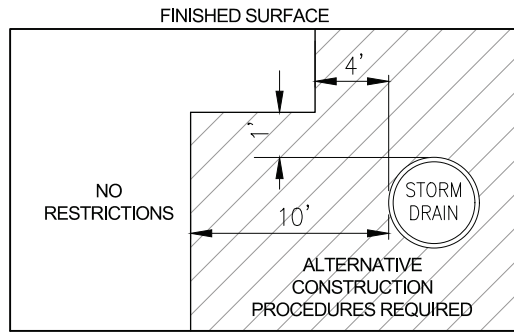

PARALLEL CONSTRUCTION REQUIREMENTS NEAR STORM DRAINS

NOTES:

1. New water mains shall not be installed in the same trench and shall be at least 4 feet horizontally from and 1 foot vertically above any parallel pipeline conveying:
 - a. storm drainage
 - b. disinfected tertiary recycled water
2. Use professional judgement to propose construction that is protective of public health.
3. The vertical separation in Case B is required when the horizontal separation is less than 10 feet.

CASE C

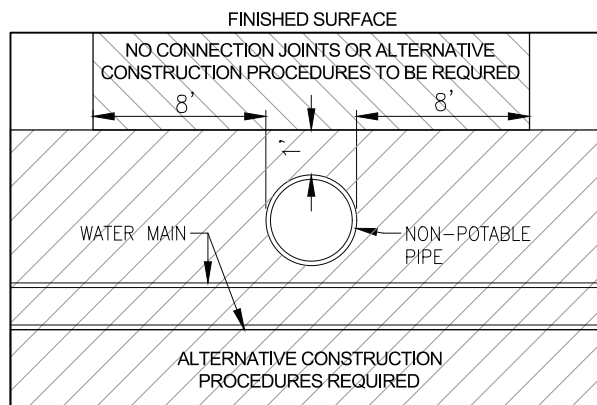

NOTES:

CROSSING CONSTRUCTION REQUIREMENTS NEAR NON-POTABLE PIPELINES

1. New water mains crossing a pipeline carrying non-potable water fluids (as listed in Case A or Case B) shall be constructed no less than 45-degrees to and at least 1 foot above the pipeline. Alternative construction procedures are not required if the angle of the crossing is greater than 45 degrees and the water main is at least 1 foot above the pipe being crossed.
2. Alternative construction procedures are not required if there are no connection joints made in the waterline within 8 feet horizontal measured on either side of the non-potable fluid pipeline (wall to wall measurement) when crossing above a non-potable fluid pipeline.
3. Use professional judgement to propose construction that is protective of public health.

APPROVED BY:
GSWC STANDARDS COMMITTEE

Alison Sweet

EDC MANAGER

6/15/26
DATE



Golden State
Water Company

A Subsidiary of American States Water Company

TITLE:

PIPELINE SEPARATION
REQUIREMENTS

SCALE:
NONE

DATE:
11/01/25

REV
2026

STANDARD DWG NO.
P-2A

GENERAL NOTES:

- 1) Application of this standard drawing must comply with Section 64572, Title 22, California Code of Regulations, latest revision.
- 2) If the condition of the existing sewer cannot be readily determined, the alternative construction requirements for water mains described below shall apply depending on if the crossing is perpendicular or parallel.
- 3) A "sewer line" is defined as a pipeline conveying non-potable water or hazardous liquids including but not limited to storm drainage, recycled water, sewage and fuels.
- 4) All exceptions to these minimum separation standards must be reviewed by the Division of Drinking Water (DDW) and a written waiver obtained prior to construction of the crossing.

I. Separation Standards per Division of Drinking Water Requirements (DDW)

a. The Minimum Separation Requirements Between Water Mains And Non-Potable Pipelines As Contained In Section 64572, Title 22, California Code Of Regulations

i. Parallel Construction Requirements:

1. Sewer Lines: Water mains shall be at least 10 feet clear horizontal distance from sewer lines and 1 foot clear vertical distance above sewer lines.
2. Storm Drain Or Recycled Water Pipelines: Water mains shall be at least 4 feet clear horizontal and 1 foot clear vertical distance above storm drain or recycled water pipelines.

ii. Crossing Construction Requirements: When pipelines must cross, potable water mains shall be at least 1 foot clear above non-potable pipelines and at no less than 45-degrees crossing angle.

iii. Separation distances as specified shall be measured from the nearest outside edge of each pipeline; i.e. the clear distance.

- iv. Water mains and sewer lines must **not** be installed in the same common trench.
- v. New water mains shall not be installed within 100 horizontal feet of the nearest edge of any sanitary landfill, wastewater disposal pond or hazardous waste disposal site or within 25 horizontal feet of the nearest edge of any cesspool, septic tank, sewage leach field, seepage pit, underground hazardous material storage tank or groundwater recharge project site without written approval of the Department of Drinking Water.

b. Exceptions to Basic Separation Standards

- i. Local conditions may create a situation where there is no alternative but to install water mains at a distance less than that required by the Basic Separation Standards above. In such cases alternative construction criteria as shown below should be followed.
- ii. Sewer mains of 24 inches in diameter or larger may create special hazards because of the large volumes of flow from a pipeline break. Therefore installations of water mains in the vicinity of sewer mains 24 inches in diameter or larger must be reviewed on a case-by-case basis by DDW to determine if the separation and protection measures are adequate.

<p>APPROVED BY: GSWC STANDARDS COMMITTEE</p>  <p>EDC MANAGER</p> <p>6/15/26 DATE</p>	 <p>Golden State Water Company <small>A Subsidiary of American States Water Company</small></p>	<p>TITLE: PIPELINE SEPARATION REQUIREMENTS</p>			
		<p>SCALE: NONE</p>	<p>DATE: 07/23/24</p>	<p>REV 2026</p>	<p>STANDARD DWG NO. P-2B</p>

GENERAL NOTES CONTINUED:

II. Construction of Water Lines Parallel to Sewer and Storm Drain Lines

- a. See Case A and Case B
- b. New water mains in this zone shall be constructed of Special Pipe Materials (see Section VI). Joints shall be restrained.

III. Construction of Water Lines Crossing Sewer and Storm Drain Lines

- a. See Case C
- b. The new water main in this zone shall have no joints in the area over the existing non-potable pipe unless they are restrained and shall be constructed of Special Pipe Material. Water main inverts under existing sewer or storm drain piped shall be constructed as shown on GSWC Standard Drawings P-39, P-40, P-41 or P-42.

IV. Crossings of a Sewer Force Main

- a. In addition to other sewer requirements, when a new water main crosses over an existing sewer force main the water main shall be constructed of pipe materials with a minimum rated working pressure of 200 psi.
- b. No water main shall cross **under** a sewer force main.

V. Crossings of Gravity Sewer Laterals

- a. Special construction criteria, as defined above, shall apply to sewer laterals that cross above a potable water main but not to sewer laterals that cross below a potable water main.

VI. Definition of Special Pipe Material

- a. Ductile iron pipe (Class 350) with bitumastic coating (AWWA C151), or
- b. Cement mortar lined and coated (AWWA C200) rated at 200 psi or greater, or
- c. PVC water pipe (Class 235 DR18) (AWWA C900) or equivalent, or
- d. Reinforced Concrete Pressure Pipe, Steel Cylinder Pipe, 200 psi minimum, (AWWA C300, C301 or C303, latest revisions), or
- e. HDPE pipe with fusion welded joints, (DR-18, 200 psi minimum) (AWWA C906)

APPROVED BY:
GSWC STANDARDS COMMITTEE

Alison Sweet

EDC MANAGER

6/15/26
DATE



Golden State
Water Company

A Subsidiary of American States Water Company

TITLE:

PIPELINE SEPARATION
REQUIREMENTS

SCALE:
NONE

DATE:
11/01/25

REV
2026

STANDARD DWG NO.
P-2C

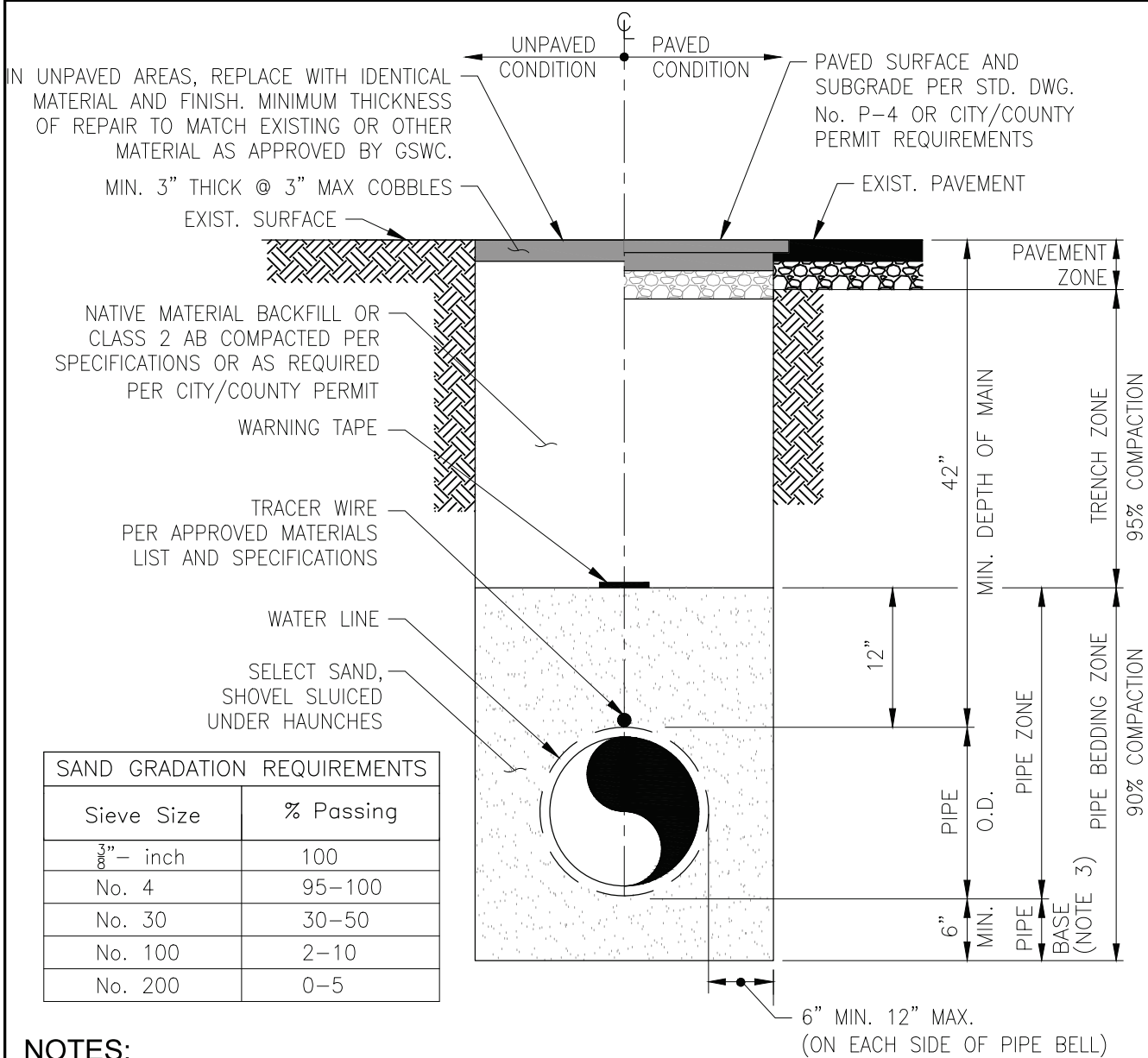

SAND GRADATION REQUIREMENTS	
Sieve Size	% Passing
3/8" - inch	100
No. 4	95-100
No. 30	30-50
No. 100	2-10
No. 200	0-5

NOTES:

1. Trench and pavement per City/County permit requirements or as noted on the drawing and Std. Dwg. No. P-4.
2. Compaction of backfill per specifications.
3. Pipe base shall be 12" thick where native material has rocks larger than 6 inches in trench bottom.
4. Contractor shall hand excavate "bell hole" for each pipe joint so that the weight of the pipe does not rest on the bell. Contractor to refill and hand-tamp each "bell hole" prior to completing the placement of the bedding.
5. For areas where native soil contains cobbles and large stones (such as Rancho Cordova), place geotechnical filter fabric between Pipe Zone and Trench Zone backfill to prevent migration of rocks to the pipe.
6. Encase D.I.P. and fittings in polyethylene encasement per AWWA Standard C-105, latest edition, and per GSWC specifications.
7. Table shows gradation requirements for backfill in Pipe Bedding Zone.
8. Tracer wire shall be tested for electrical continuity by the Contractor prior to acceptance of the project.

APPROVED BY:
GSWC STANDARDS COMMITTEE

Alison Sweet

EDC MANAGER

6/15/26
DATE



Golden State
Water Company

A Subsidiary of American States Water Company

TITLE:

WATER PIPE BEDDING AND
TRENCH BACKFILL

SCALE:
NONE

DATE:
11/01/25

REV
2026

STANDARD DWG NO.
P-3

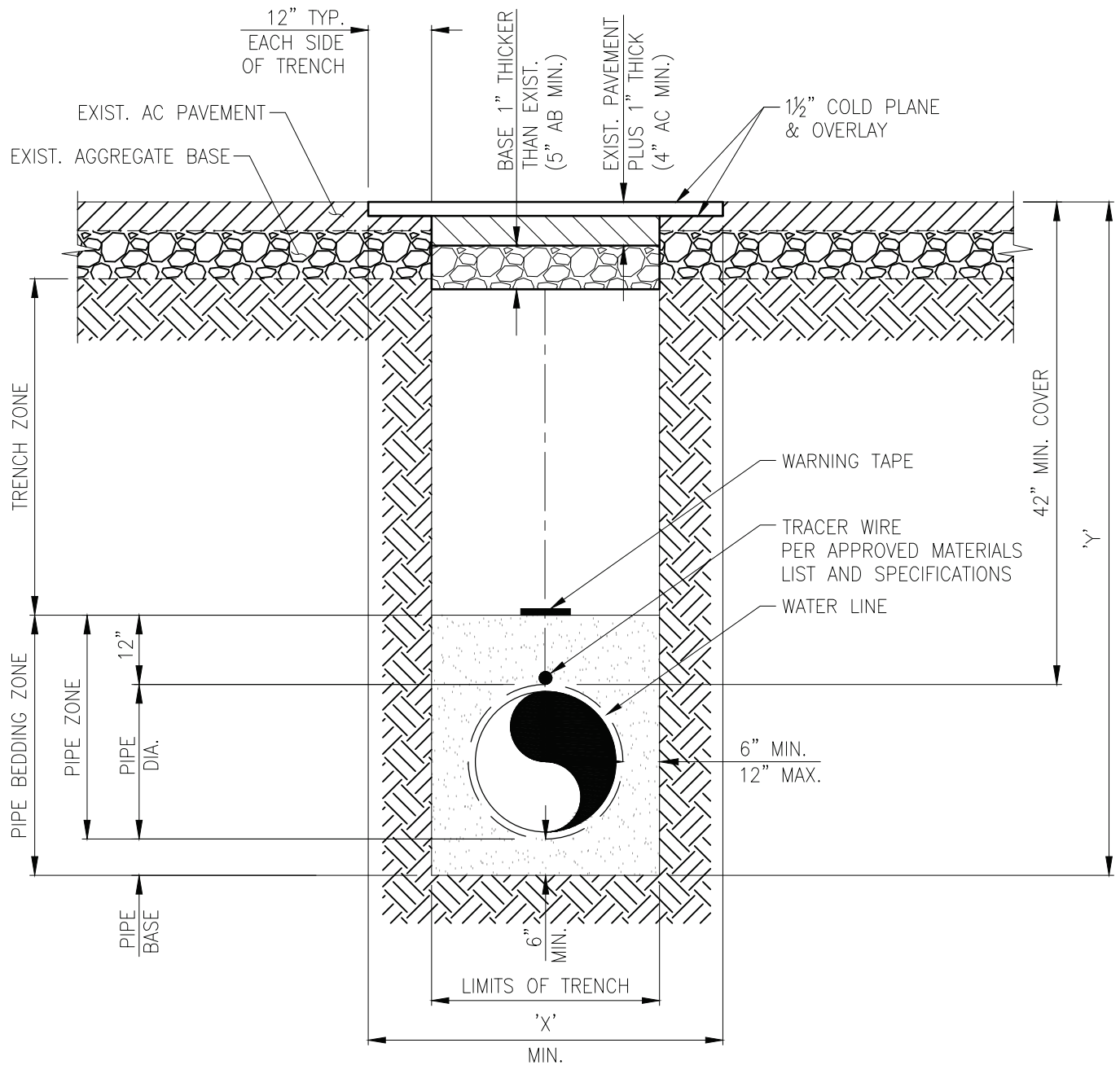

NOTES:

1. For specific repaving requirements see permit from City/County.
2. Contractor to clean surfaces that are adjacent new paving and remove rocks, dirt, old paving and/or old concrete that would prevent pavement compaction equipment from keeping contact with the new paving and prevent proper compaction of the new pavement.

TRENCH DIMENSIONS		
PIPE DIA. (Inches)	X DISTANCE (Inches)	Y DISTANCE (Inches)
6	42	54
8	44	56
12	48	60
16	52	64
24	60	72
30	66	78

APPROVED BY:
GSWC STANDARDS COMMITTEE

Alison Sweet

EDC MANAGER

6/15/26
DATE



Golden State
Water Company

A Subsidiary of American States Water Company

TITLE:

TRENCH REPAVING

SCALE:
NONE

DATE:
11/01/25

REV
2026

STANDARD DWG NO.
P-4

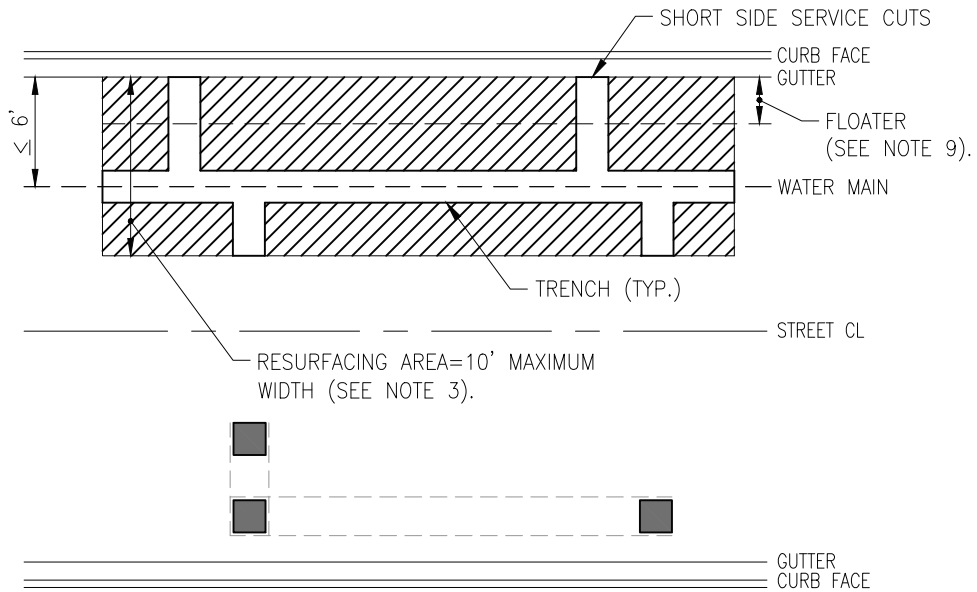

SCENARIO A

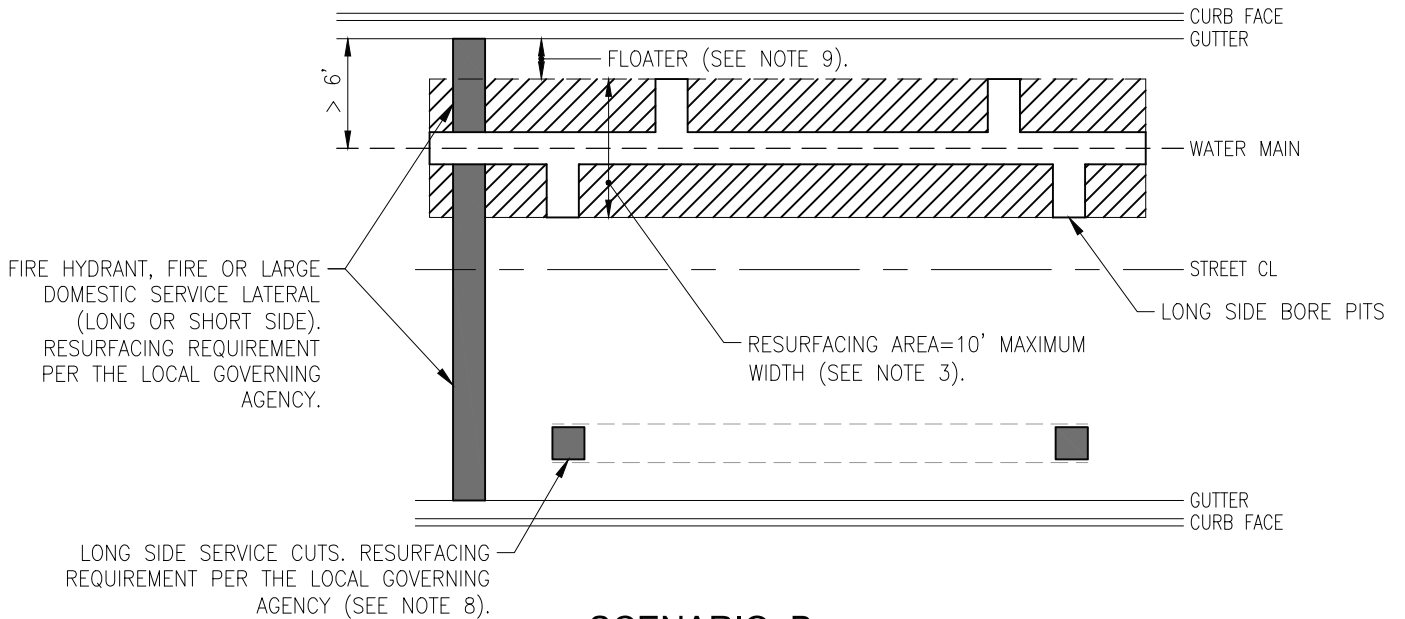

SCENARIO B

NOTES:

1. ■ Trench repairs per the local governing agency to be included in it's respective bid item.
2. ▨ 1-1/2" or 2" grind and cap per the local governing agency, shall encompass the pipeline trench and domestic service cuts.
3. The resurfacing area over the trench shall maintain a constant width throughout the entire project.
4. The cost to grind and cap the resurfacing area shall be included in it's respective bid item for the pipeline or domestic service installations.
5. SCENARIO A - Short side domestic services shall be installed by method of open cut or pneumatic bore.
6. SCENARIO B - Short side domestic services shall be installed by pneumatic bore. no services shall be open cut unless authorized by GSWC.
7. SCENARIO A AND B - Long side domestic services shall be installed by use of pneumatic bore. no services shall be open cut unless authorized by GSWC.
8. Long side service cuts shall be uniform in size and alignment.
9. Floater (section between the edge of trench to the edge of existing pavement) 2-3 ft., or as required by the local governing agency. If less than 2 ft., repave to gutter.

APPROVED BY:
GSWC STANDARDS COMMITTEE

Alison Sweet

EDC MANAGER

6/15/26
DATE



Golden State
Water Company

A Subsidiary of American States Water Company

TITLE:

AC RESURFACING

SCALE:
NONE

DATE:
06/30/23

REV
2024

STANDARD DWG NO.
P-5

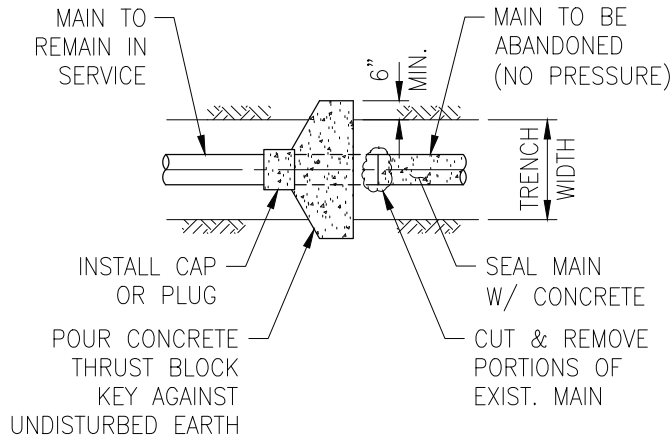

CONDITION "A"

EXIST. AC, PVC, CI OR DIP MAINS

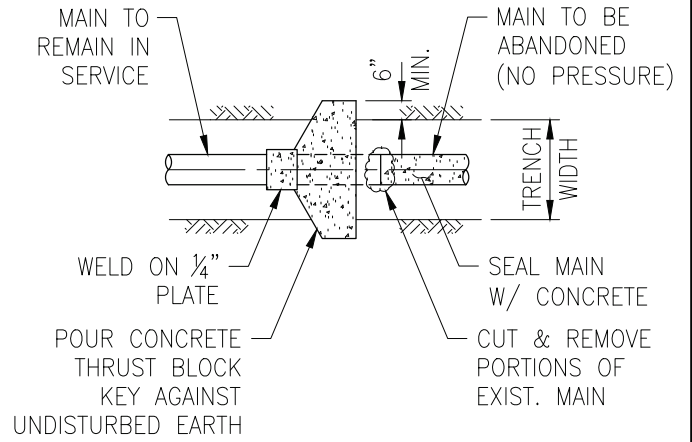

CONDITION "B"

EXIST. STEEL MAINS

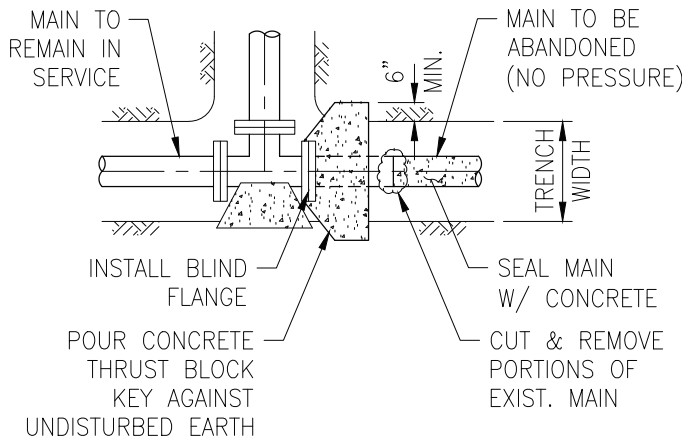

CONDITION "C"

EXIST. FLANGED FITTING OR VALVE

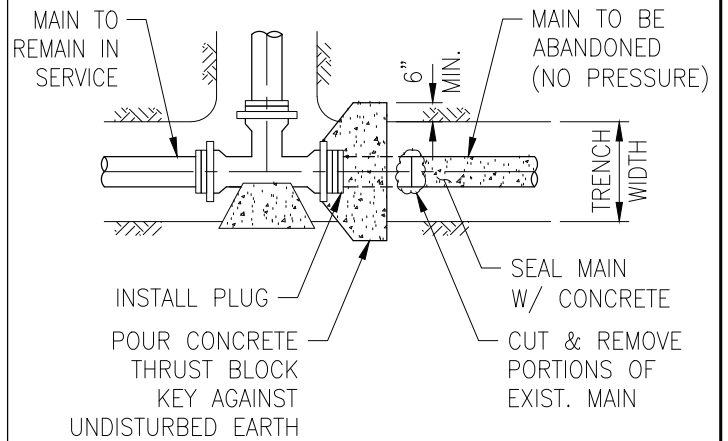

CONDITION "D"

EXIST. MJ END FITTING OR VALVE

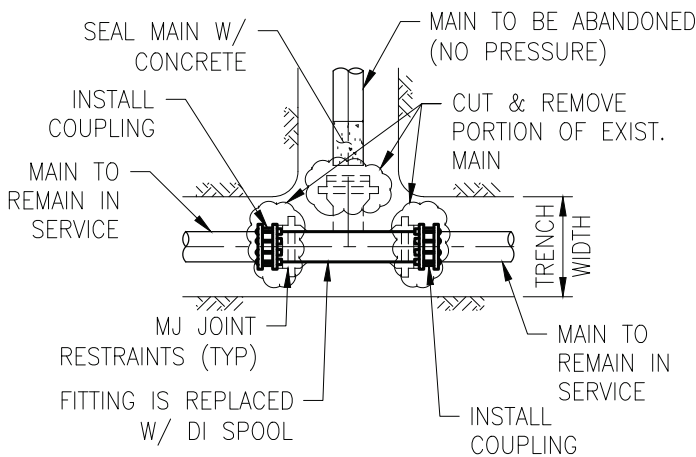

REMOVE EXIST. TEE

COMMON WHEN ABANDONING MAINS IN ALLEYWAYS & BACKYARD EASEMENTS

NOTES:

1. Bearing area against undisturbed soil shall be the same as for dead ends. See Std. Dwg. P-18 for required thrust block area.
2. When called out on plans, install blow-off.
3. Thrust blocks shall be class 560-C-3250 concrete, unless otherwise specified.
4. All buried bolts shall be coated with "Devwrap 142S".
5. Notch the undisturbed soil prior to pouring thrust blocks.
6. Concrete will be mixed completely before pouring. No mixing in the trench.

APPROVED BY:
GSWC STANDARDS COMMITTEE

Alison Sweet

EDC MANAGER

6/15/26
DATE



Golden State
Water Company

A Subsidiary of American States Water Company

TITLE:

**CUTTING & PLUGGING
WATERMAINS**

SCALE:
NONE

DATE:
11/01/25

REV
2026

STANDARD DWG NO.
P-6

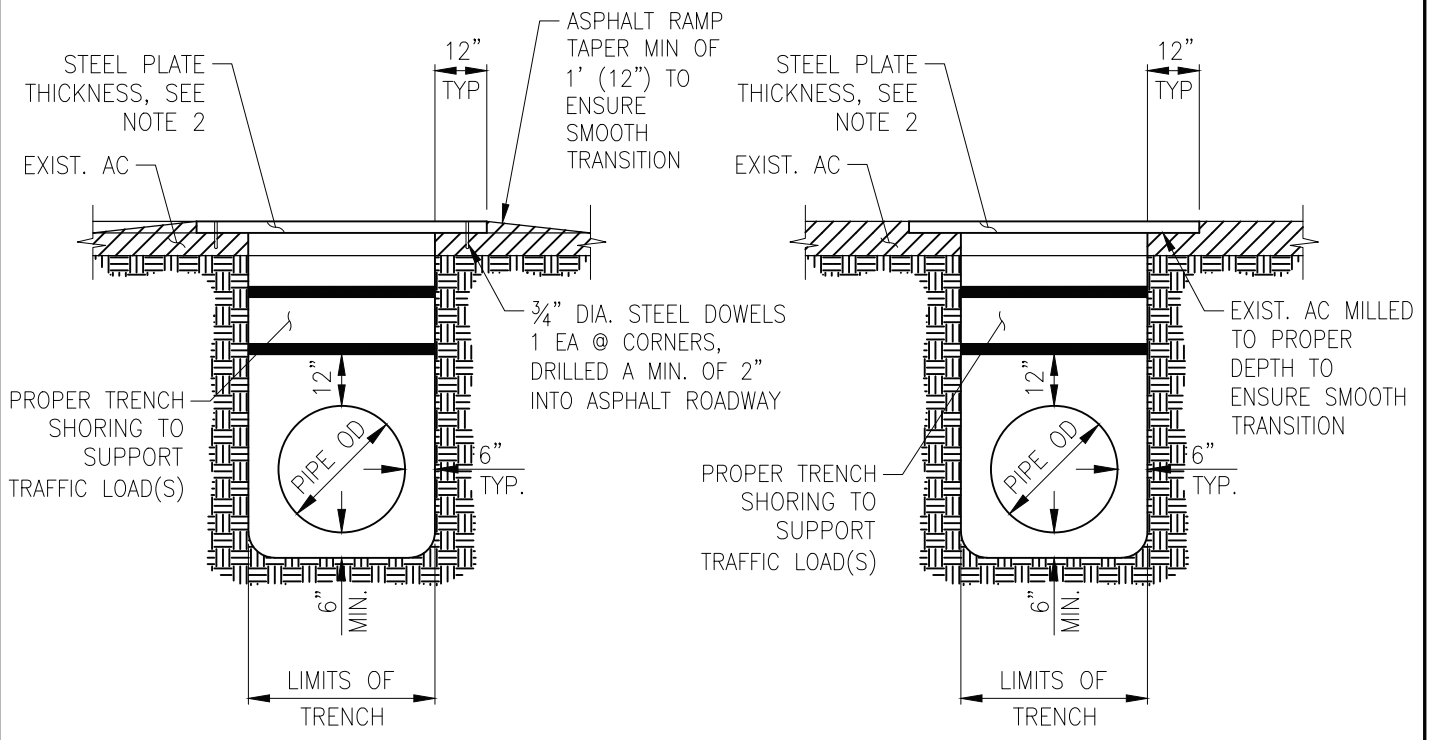

TRENCH PLATE STANDARD DRAWING FOR SPEEDS UNDER 45 MPH

TRENCH PLATE STANDARD DRAWING FOR SPEEDS OVER 45 MPH

NOTES:

1. Use of trench plates shall meet the current requirements of the City/County jurisdiction where the work is being done or this drawing, whichever is more stringent.
2. Minimum steel plate thickness based on using A-36 grade steel designed for HS20-44 truck loading per Caltrans Bridge Design Specifications Manual.

Trench Width	Min. Plate Thickness
0"-10"	1/2"
11"-23"	3/4"
23"-31"	7/8"
31"-41"	1"
41"-63"	1 3/4"

3. For spans greater than 63" a structural design shall be prepared by a California registered civil engineer.
4. All steel plates used in or out of the traveled way shall be without deformation. The GSWC representative shall determine the trueness of the steel plate by using a straight edge and will reject any plate that is permanently deformed.
5. Steel plates used in the traveled portion of the right of way shall have a surface that was manufactured with a nominal Coefficient of Friction (COF) of 0.35. The contractor shall determine what amount of surface wear is acceptable, and independently ascertain when to remove, test, or resurface an individual steel plate.
6. Contractor shall not install any steel plate that is permanently deformed or delivered without the required surfacing.
7. A warning sign meeting Caltrans standards shall be placed in advance of steel plate bridging. This sign shall be used with all other required construction signing.

APPROVED BY:
 GSWC STANDARDS COMMITTEE

 EDC MANAGER
 6/15/26
 DATE



TITLE:
 TRENCH PLATES

SCALE: NONE	DATE: 11/01/25	REV 2026	STANDARD DWG NO. P-7
----------------	-------------------	-------------	-------------------------

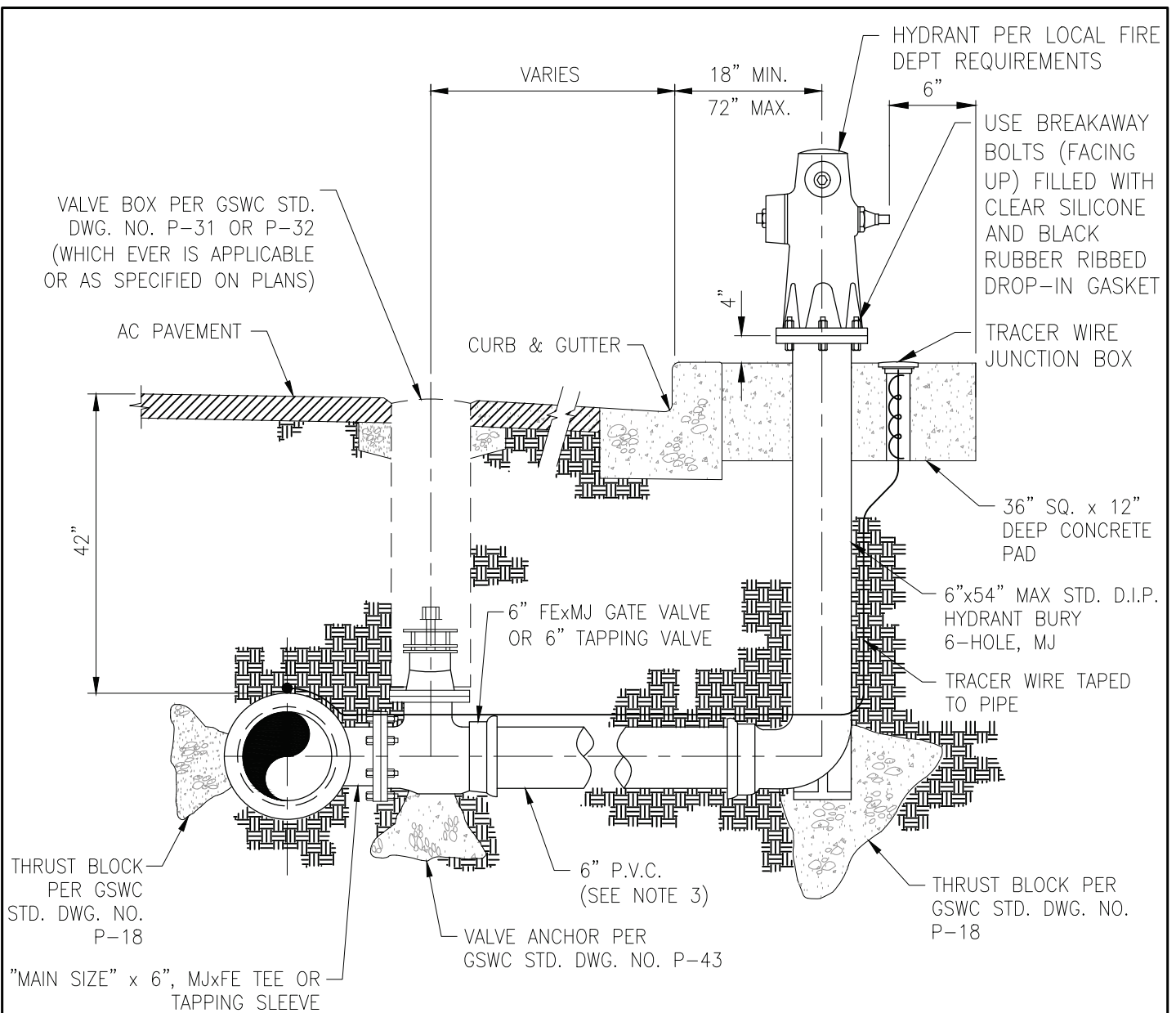

NOTES:

1. On roads without curbs, fire hydrants shall be located within the road right of way, one foot clear from the property line unless otherwise indicated on the plans. Hydrant shall be constructed on a 36" square concrete pad.
2. Hydrants, risers and curbs shall be painted per local fire department requirements.
3. Ductile iron pipe shall be used when the main line is DIP.
4. In LA County, valves shall be 10' - 25' from hydrant. Install 2 valves if distance from main is greater than 25'. Include a 90° bend on 6" lateral pipe.
5. Fire hydrants shall be located per GSWC Std. Dwg. No. C-10.
6. Fire hydrant 4" outlet shall be located perpendicular to the curb face
7. ALTERNATIVE: Use 36" long bury with extensions as required to achieve 4" min. clearance between hydrant and concrete pad.

APPROVED BY:
GSWC STANDARDS COMMITTEE

Alison Sweet

EDC MANAGER

6/15/26
DATE



Golden State
Water Company

A Subsidiary of American States Water Company

TITLE:

**6-INCH STANDARD WET
BARREL FIRE HYDRANT**

SCALE:
NONE

DATE:
11/01/25

REV
2026

STANDARD DWG NO.
P-8

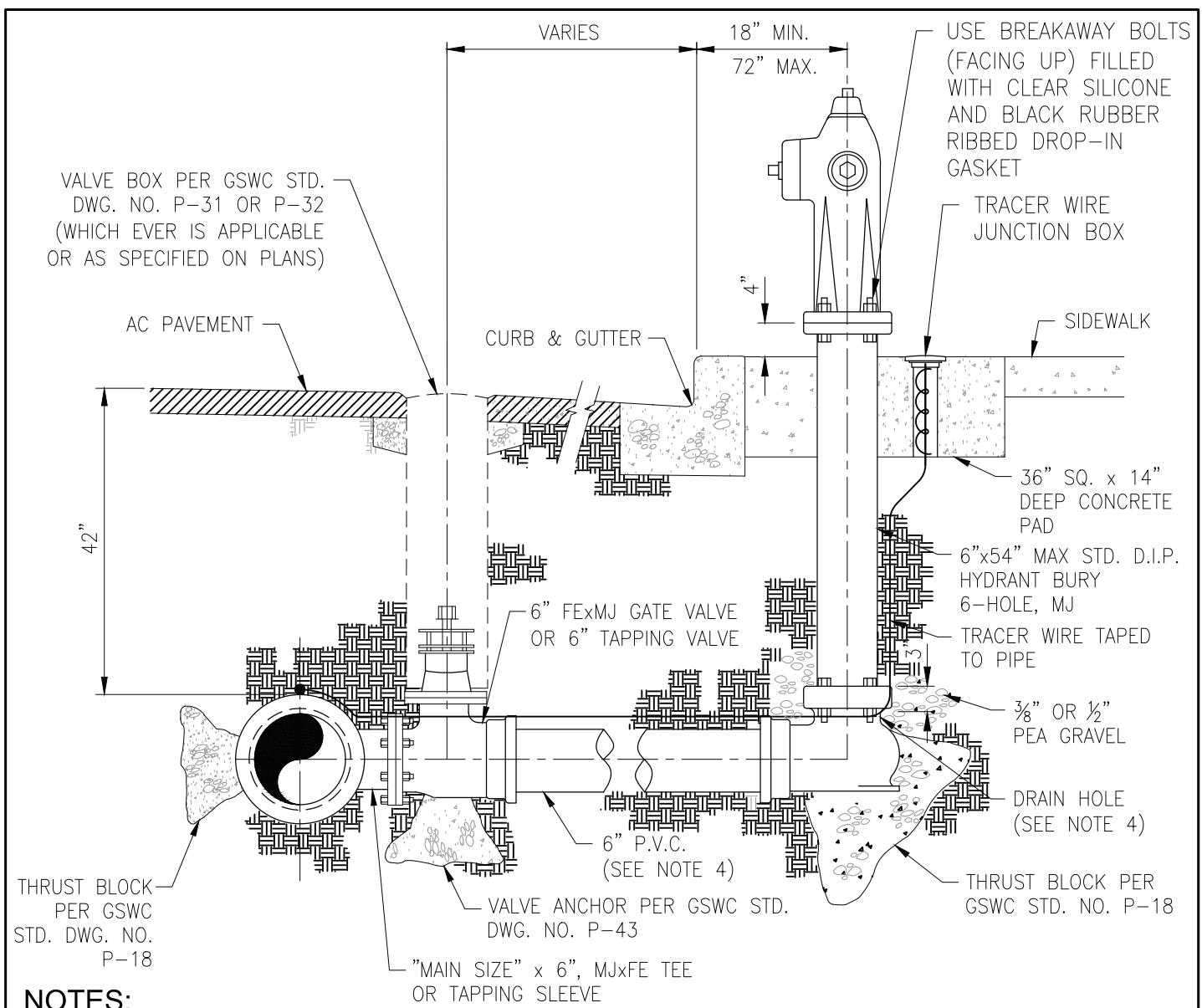

NOTES:

1. On roads without curbs, fire hydrants shall be located within the road right of way, one foot clear from the property line unless otherwise indicated on the plans. Hydrant shall be constructed on a 36" square concrete pad.
2. Hydrants, risers and curbs are to be painted per local fire department requirements.
3. Adequate clearance between thrust block and drain hole shall be provided to assure proper drainage.
4. Ductile iron pipe shall be used when the main line is DIP.
5. In LA County, valves shall be 10' – 25' from hydrant. Install 2 valves if distance from main is greater than 25'. Include a 90° bend on 6" lateral pipe.
6. Fire hydrants shall be located per GSWC Std. Dwg. No. C-10.
7. Fire hydrant 4" outlet shall be located perpendicular to the curb face
8. ALTERNATIVE: Use 36" long bury with extensions as required to achieve 4" min. clearance between hydrant and concrete pad.

APPROVED BY: GSWC STANDARDS COMMITTEE EDC MANAGER	Golden State Water Company <small>A Subsidiary of American States Water Company</small>	TITLE: 6-INCH STANDARD DRY BARREL FIRE HYDRANT
6/15/26 DATE	SCALE: NONE	DATE: 11/01/25
2026	REV	STANDARD DWG NO. P-9

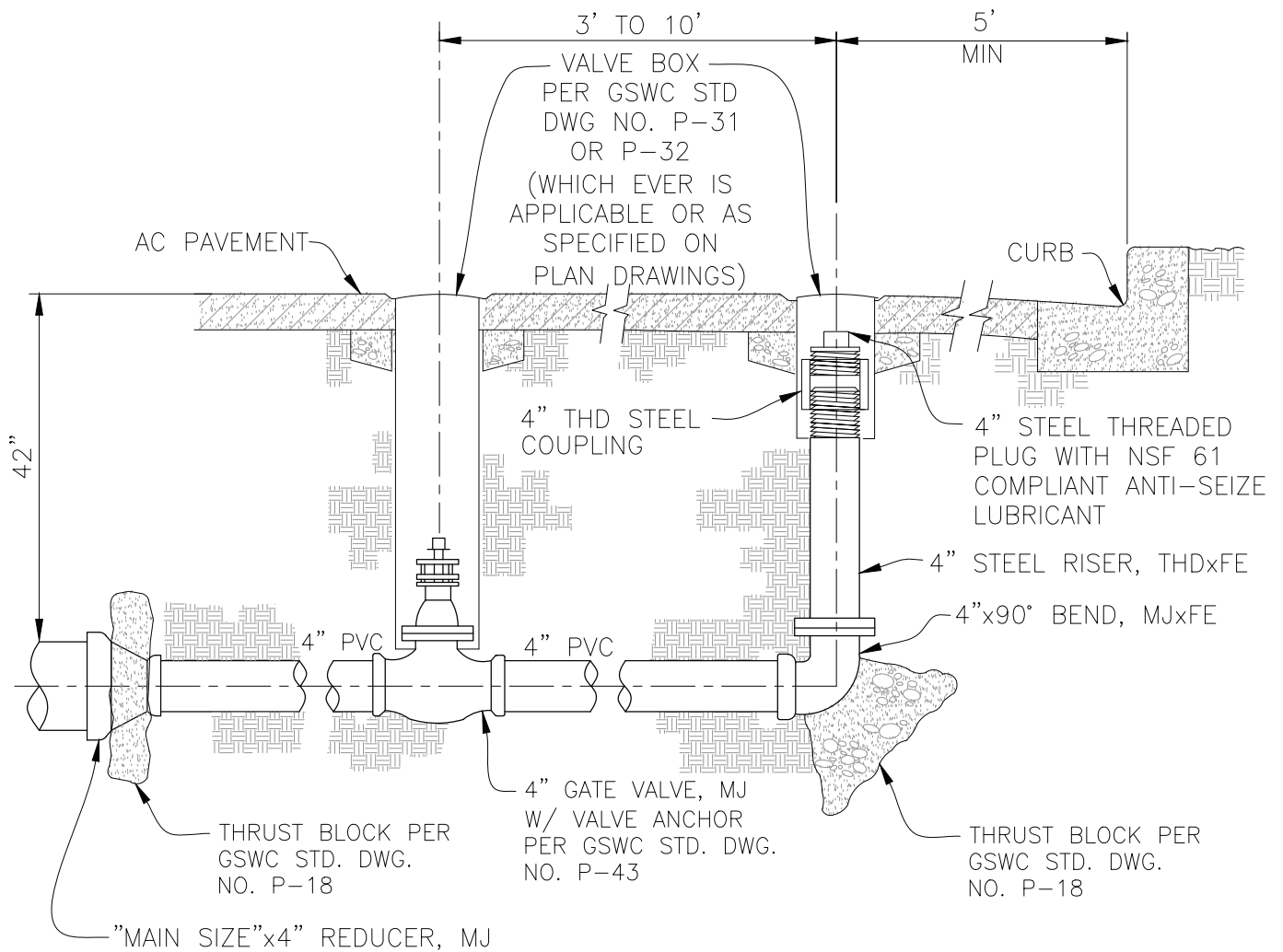

NOTES:

1. Ductile iron pipe shall be used when the main line is DIP.
2. D.I.P. shall be cement lined and bitumastic coated.
3. On roads without curbs, flush out shall be located within the road right-of-way, one foot clear from the property line unless otherwise indicated on the plans.

APPROVED BY:
GSWC STANDARDS COMMITTEE

Alison Sweet

EDC MANAGER

6/15/26
DATE



Golden State
Water Company

A Subsidiary of American States Water Company

TITLE:

4-INCH FLUSH OUT
TYPE 3

SCALE:
NONE

DATE:
02/11/26

REV
2026

STANDARD DWG NO.
P-10B

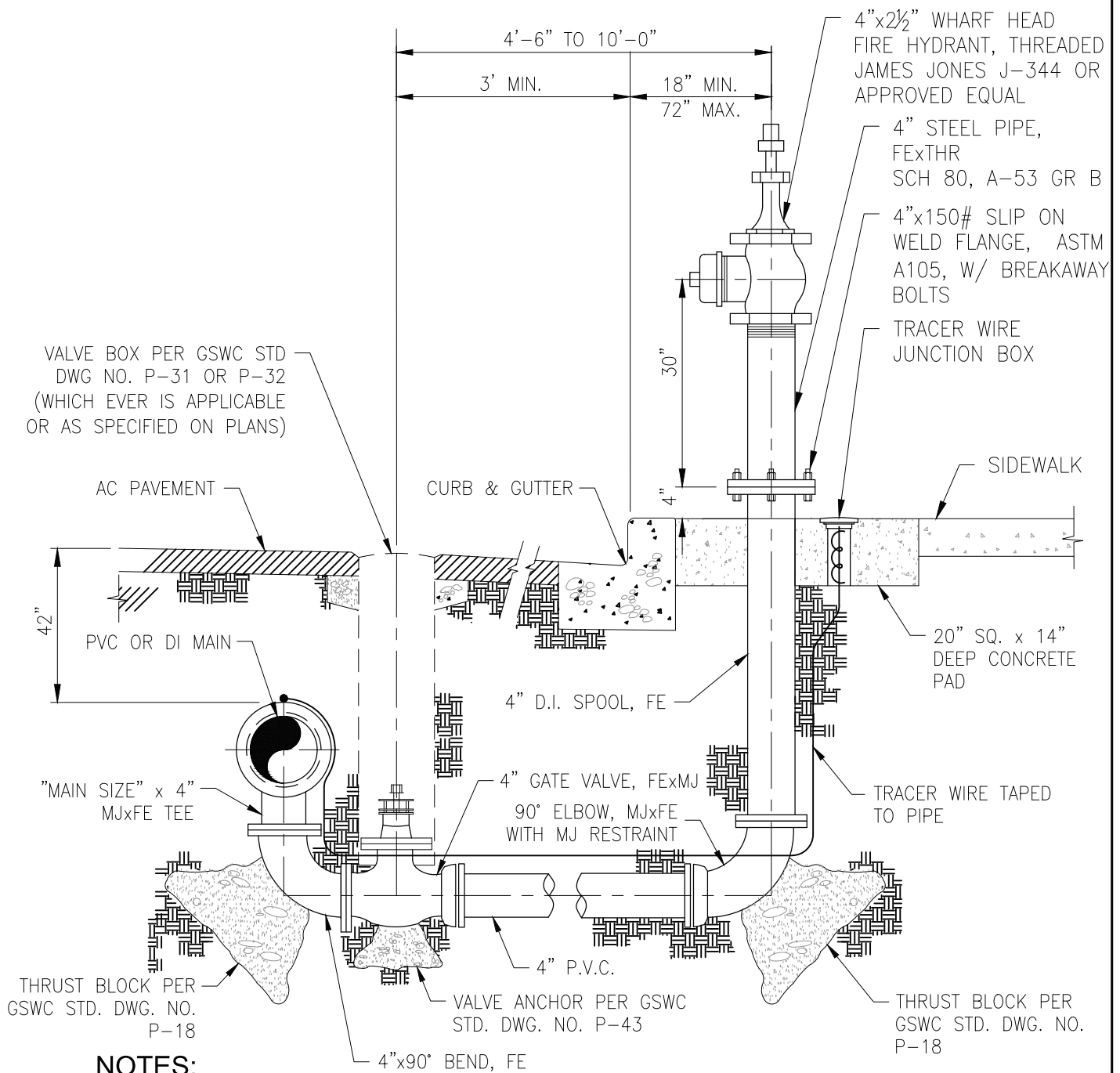

NOTES:

1. On mains 12" and larger, install a 12" long flanged spool between 90° bend and gate valve.
2. Ductile iron pipe shall be used when the main line is DIP.
3. Coating materials shall be per GSWC painting specifications for above grade piping.
4. D.I.P. shall be cement lined and bitumastic coated.
5. Blow-offs shall be located per GSWC Std. Dwg. No. C-10.
6. On roads without curbs, blow-off shall be located within the road right-of-way, one foot clear from the property line unless otherwise indicated on the plans. Blow-off shall be constructed on a 36" square concrete pad.

APPROVED BY:
 GSWC STANDARDS COMMITTEE

 EDC MANAGER
 6/15/26
 DATE



Golden State
 Water Company
 A Subsidiary of American States Water Company

TITLE: 4-INCH BLOW-OFF ASSEMBLY			
SCALE: NONE	DATE: 11/01/25	REV: 2026	STANDARD DWG NO. P-11A

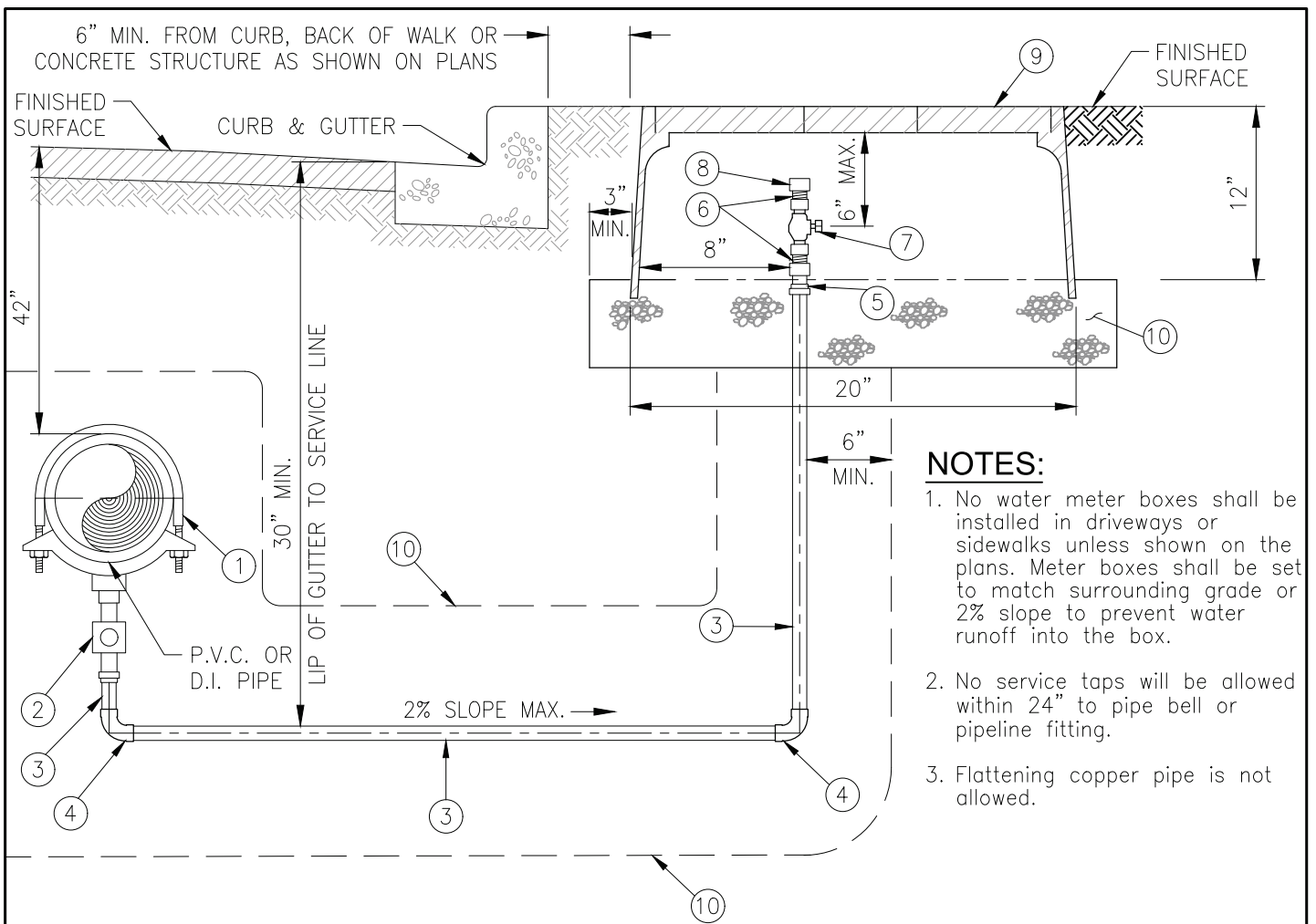

- NOTES:**
1. No water meter boxes shall be installed in driveways or sidewalks unless shown on the plans. Meter boxes shall be set to match surrounding grade or 2% slope to prevent water runoff into the box.
 2. No service taps will be allowed within 24" to pipe bell or pipeline fitting.
 3. Flattening copper pipe is not allowed.

ITEM	EACH	DESCRIPTION	SPECIFICATION	REMARKS
①	1	Service saddle	Strap to be S.S. or bronze	See Approved Materials List
②	1	2" ball valve corp. stop	2" C.C. x C.T.S. compression	See Approved Materials List
③	2	Copper tubing	2" Type K, soft	One piece only, no bends, unless elbow is used. Elbow joints to be silver soldered.
④	1	Elbow	2" C.T.S.	See Approved Materials List
⑤	1	2" straight coupling	2" F.I.P. x C.T.S. compression	See Approved Materials List
⑥	1	2" brass nipple	2" IP thread	See Approved Materials List
⑦	1	2" ball valve	2" F.I.P. x F.I.P.	See Approved Materials List
⑧	1	2" plastic cap	2" ABS plastic cap F.I.P.	See Approved Materials List
⑨	1	Water meter box pad	14"x24"x6", 3/4" crushed rock	Pad for meter box
⑩	1	Trench with sand envelope	Imported with SE > 30	12" min. & 24" max. trench width

APPROVED BY:
GSWC STANDARDS COMMITTEE

Alison Sweet

EDC MANAGER

6/15/26
DATE



Golden State
Water Company

A Subsidiary of American States Water Company

TITLE:

**2-INCH BLOW-OFF
ASSEMBLY**

SCALE:
NONE

DATE:
02/17/26

REV
2026

STANDARD DWG NO.
P-11B

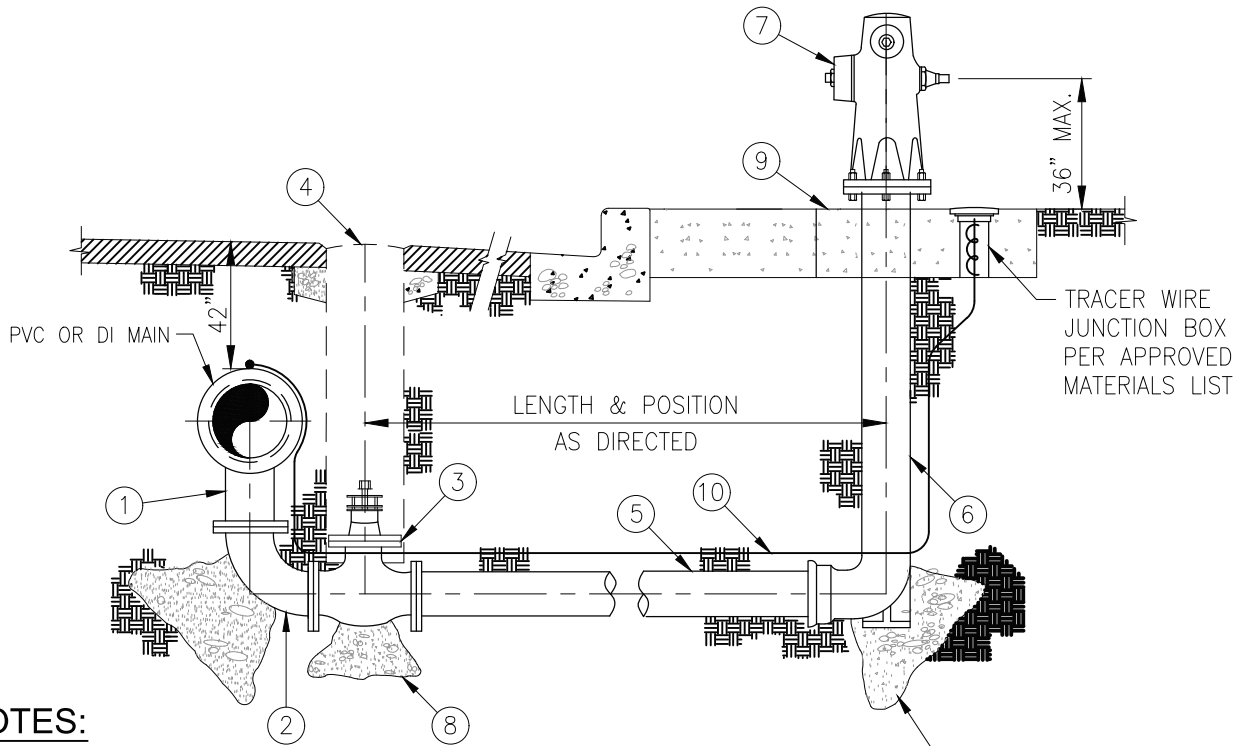

NOTES:

1. Restrained joints are required.
2. Blow-off (hydrant body) to be painted "Safety Yellow" for potable water.
3. Blow-off shall be located similar to GSWC Std. Dwg. No. C-10 for fire hydrants.
4. DIP shall be cement lined and bitumastic coated.
5. On roads without curbs, flush out shall be located in the road right-of-way, one foot clear from the property line unless otherwise indicated on the plans. Flush out shall be constructed on a 36" square concrete pad.
6. On mains 12" and larger, install a 12" long flanged spool between 90° bend and gate valve.

ITEM	EACH	DESCRIPTION	DESCRIPTION	REMARKS
①	1	Std. 6" tee branch	D.I. flg on 6" branch	Set vertically down
②	1	6" 90° L.R. bend	D.I. 6" long radius, FLxFL	With thrust block
③	1	6" gate valve		Resilient wedge, FLxFL
④	1	8" valve well and cap	Std. Dwg. P-31 or P-32	
⑤	1	6" pipe blow-off lateral		FExFE or FExPE DIP or PVC
⑥	1	6" std. fire hydrant bury		6 hole FExFE or FExMJ (6"x54" MIN.)
⑦	1	6" residential fire hydrant	Std. Dwg. P-8 or P-9	4"x2½" James Jones JJ-3700, painted
⑧	-	Valve anchor, Per GSWC Std. Dwg. No. P-43		
⑨	1	560 C3250 concrete pad	36"SQ x 14" deep	
⑩	1	tracer wire taped to pipe		

APPROVED BY:
GSWC STANDARDS COMMITTEE

Alison Sweet

EDC MANAGER

6/15/26
DATE



Golden State
Water Company

A Subsidiary of American States Water Company

TITLE:

**6-INCH FLUSH OUT
ASSEMBLY**

SCALE:
NONE

DATE:
11/01/25

REV
2026

STANDARD DWG NO.
P-12

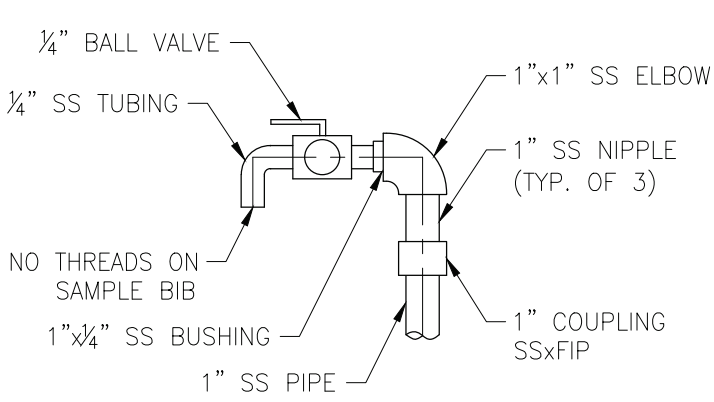

SAMPLE VALVE DETAIL

N.T.S.

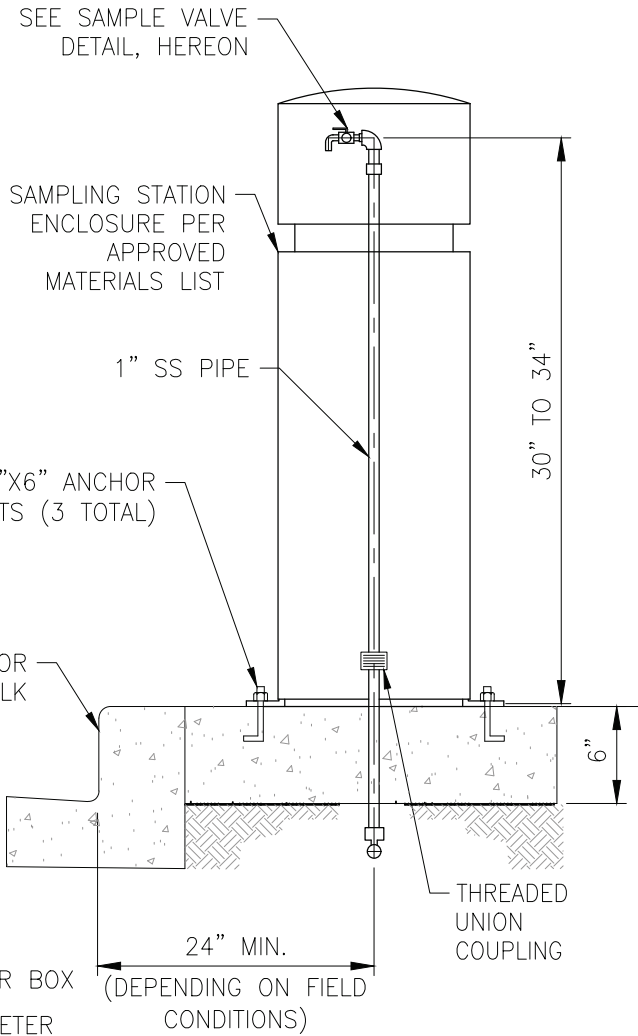

SECTION A-A

N.T.S.

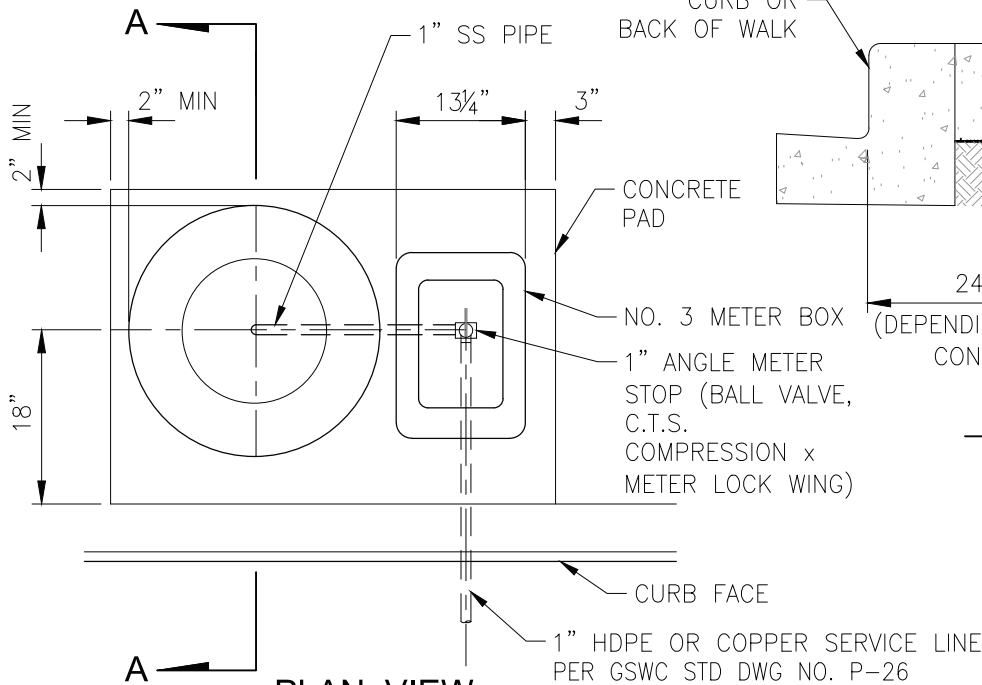

PLAN VIEW

N.T.S.

NOTES:

1. No sampling stations shall be installed beyond limits of public right of way without easements.
2. Door shall open to side opposite vehicular traffic.
3. Sampling stations shall be located similar to GSWC Std. Dwg. No. C-10 for Fire Hydrants.
4. Stainless steel materials to be electrically insulated from D.I.P. or copper materials.
5. In areas subject to freezing temperatures use sampling stations designed for use in freezing climates. See Potable Water Materials Guideline.
6. Paint curb face red for 6' each side of sampling station.

APPROVED BY:
GSWC STANDARDS COMMITTEE

Alison Sweet

EDC MANAGER

6/15/26
DATE



Golden State
Water Company

A Subsidiary of American States Water Company

TITLE:

SAMPLING STATION

SCALE:	DATE:	REV	STANDARD DWG NO.
NONE	11/03/25	2026	P-13

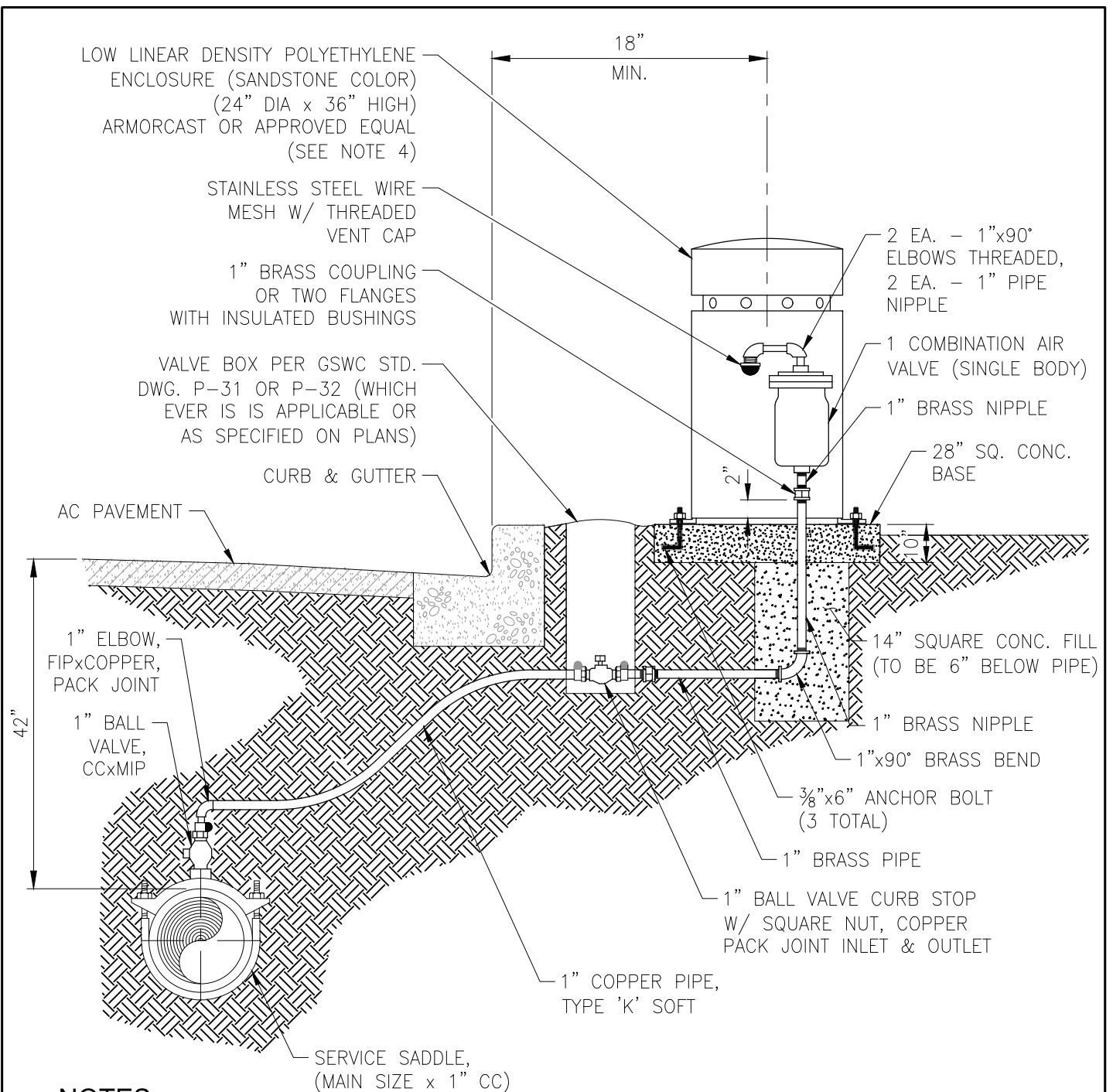

NOTES:

1. Maintain positive slope from main to air release valve.
2. Slip-on or copper fittings with silver solder brazing shall be used in lieu of copper pack joints.
3. Air valve assembly shall be located similar to GSWC Std. Dwg. No. C-10 for fire hydrants.
4. As an alternative the enclosure can be 12" dia. x 24" high.
5. On roads without curbs, air valve assembly shall be located within the road right of way, one foot clear from the property line unless otherwise indicated on the plans. Air valve assembly shall be constructed on a 28" square concrete pad.

APPROVED BY:
GSWC STANDARDS COMMITTEE

Alison Sweet

EDC MANAGER

6/15/26
DATE



Golden State
Water Company

A Subsidiary of American States Water Company

TITLE:

1-INCH COMBINATION
AIR RELEASE & VACUUM VALVE

SCALE:
NONE

DATE:
11/01/25

REV
2026

STANDARD DWG NO.
P-14

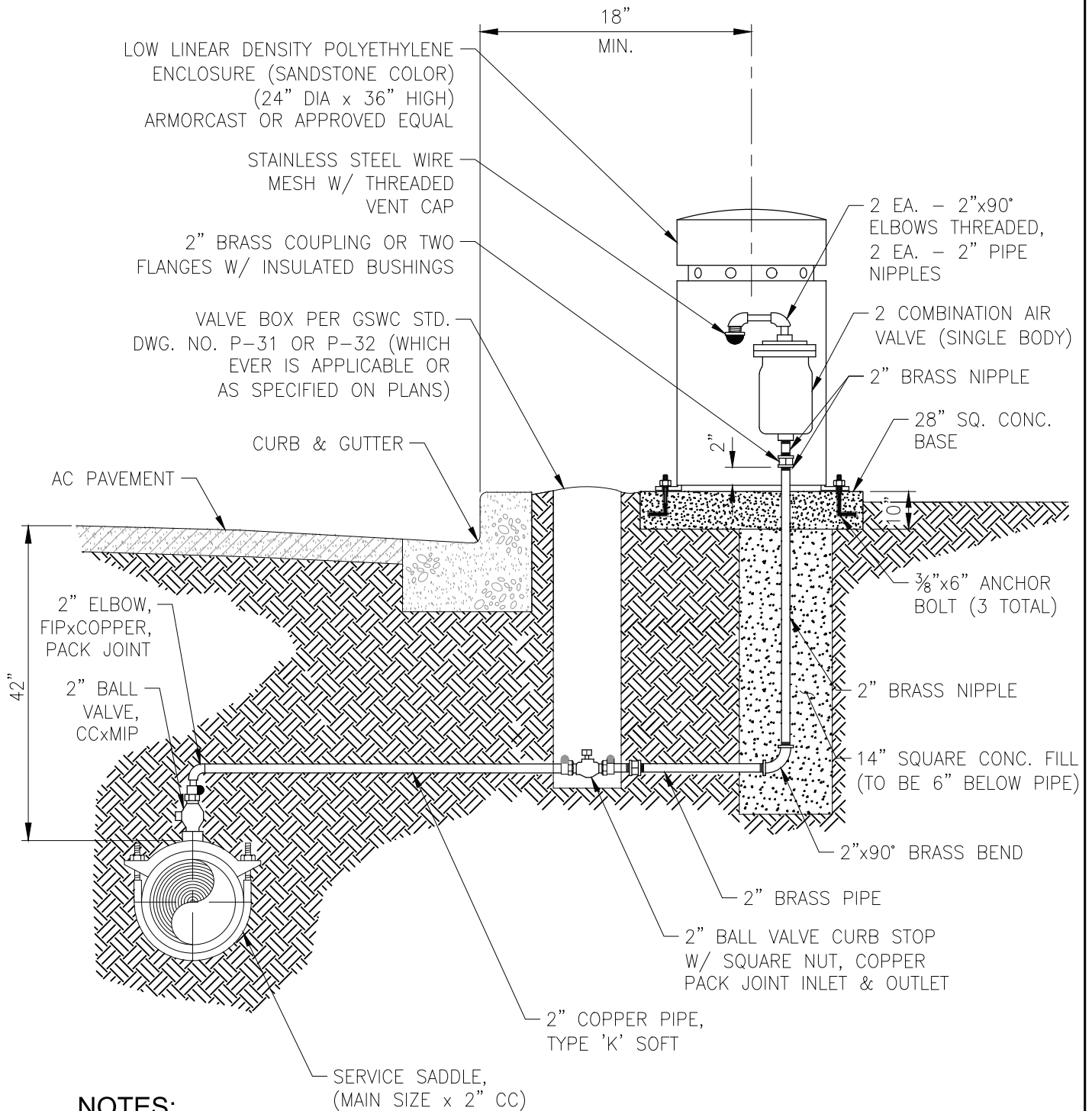

NOTES:

1. Maintain positive slope from main to air release valve.
2. Slip-on or copper fittings with silver solder brazing shall be used in lieu of copper pack joints.
3. Air valve assembly shall be located similar to GSWC Std. Dwg. No. C-10 for fire hydrants.
4. On roads without curbs, air valve assembly shall be located within the road right of way, one foot clear from the property line unless otherwise indicated on the plans. Air valve assembly shall be constructed on a 28" square concrete pad.

APPROVED BY:
GSWC STANDARDS COMMITTEE

Alison Sweet

EDC MANAGER

6/15/26
DATE



Golden State
Water Company

A Subsidiary of American States Water Company

TITLE:

2-INCH COMBINATION
AIR RELEASE & VACUUM VALVE

SCALE:
NONE

DATE:
11/03/25

REV
2026

STANDARD DWG NO.
P-15

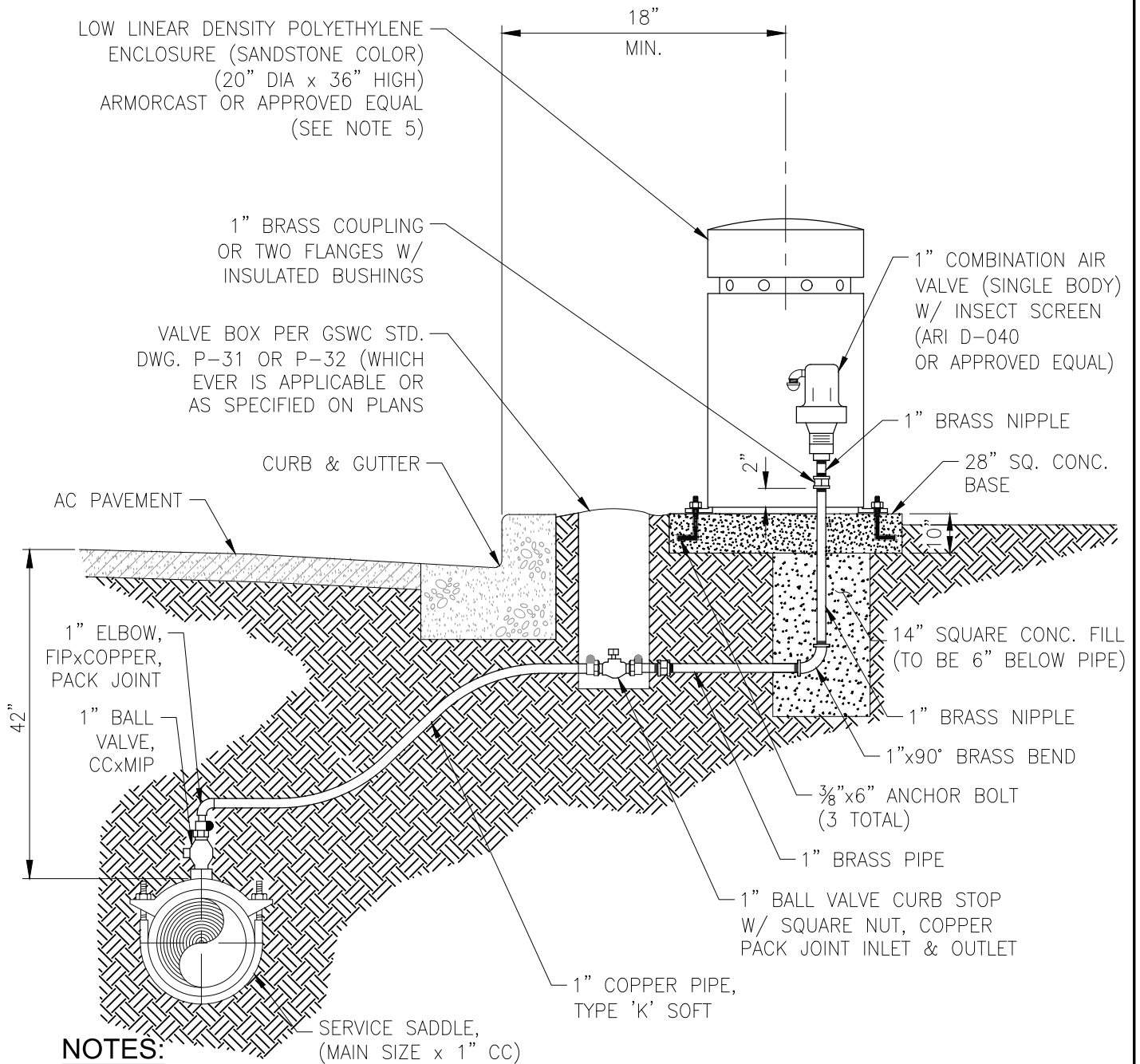

NOTES:

1. Maintain positive slope from main to air release valve.
2. Slip-on or copper fittings with silver solder brazing shall be used in lieu of copper pack joints.
3. Air valve assembly shall be located similar to GSWC Std. Dwg. No. C-10 for fire hydrants.
4. A foam insulator shall be used around A/V valve body, in areas where there are freezing conditions. See Approved Materials List.
5. As an alternative, the enclosure can be 12" dia. x 24" high.
6. On roads without curbs, air valve assembly shall be located within the road right of way, one foot clear from the property line unless otherwise indicated on the plans. Air valve assembly shall be constructed on 28" square concrete pad.

APPROVED BY:
GSWC STANDARDS COMMITTEE

Alison Sweet

EDC MANAGER

6/15/26
DATE



Golden State
Water Company

A Subsidiary of American States Water Company

TITLE:

1-INCH COMPACT STYLE COMBINATION
AIR RELEASE & VACUUM VALVE

SCALE:
NONE

DATE:
11/03/25

REV
2026

STANDARD DWG NO.
P-16A

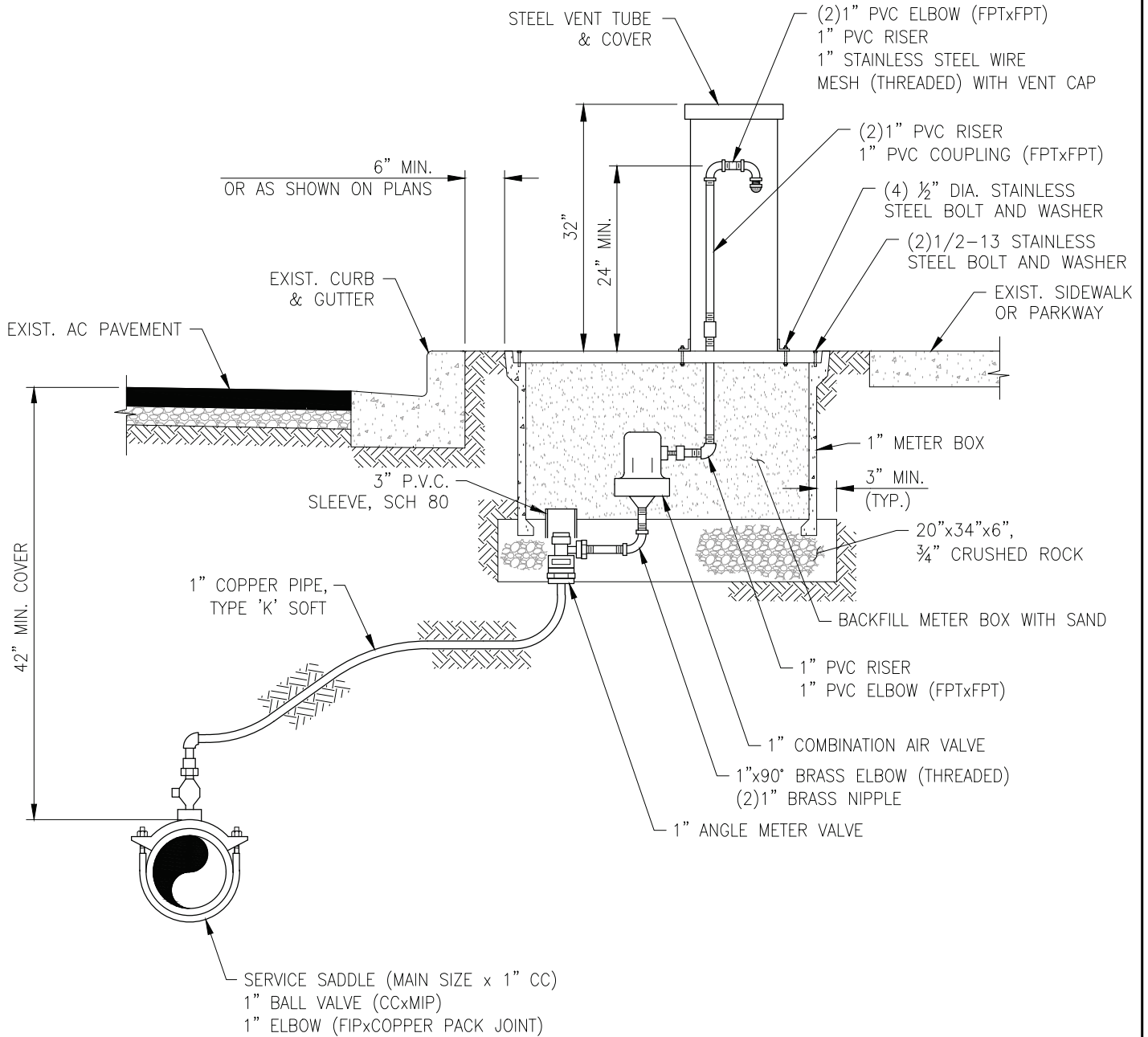

NOTES:

1. Maintain positive slope from main to air release valve.
2. Slip-on or copper fittings with silver solder brazing shall be used in lieu of copper pack joints.
3. Air valve assembly shall be located similar to GSWC STD. DWG. NO. C-10 for fire hydrants.
4. A foam insulator shall be used around air valve body. See Approved Materials List.
5. On roads without curbs, the meter box shall be located within the road right-of-way, one foot clear from the property line unless otherwise indicated on the plans.

APPROVED BY:
GSWC STANDARDS COMMITTEE

Alison Sweet

EDC MANAGER

6/15/26
DATE



Golden State
Water Company

A Subsidiary of American States Water Company

TITLE: 1-INCH COMBINATION
AIR RELEASE & VACUUM VALVE
FOR COLD WEATHER CLIMATE

SCALE:	DATE:	REV	STANDARD DWG NO.
NONE	11/03/25	2026	P-16B

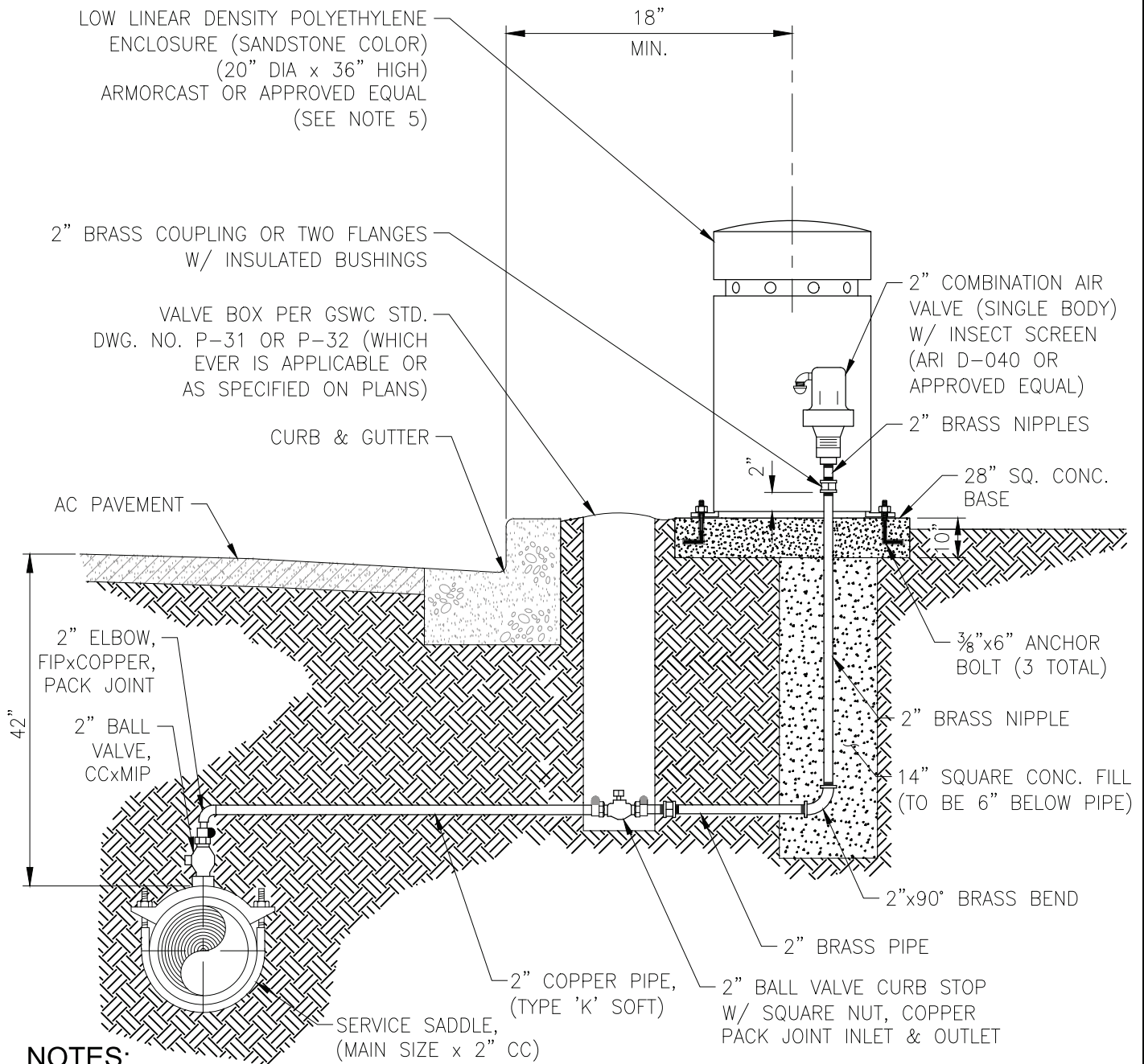

NOTES:

1. Maintain positive slope from main to air release valve.
2. Slip-on or copper fittings with silver solder brazing shall be used in lieu of copper pack joints.
3. Air valve assembly shall be located similar to GSWC Std. Dwg. No. C-10 for fire hydrants.
4. A foam insulator shall be used around A/V valve body, in areas where there are freezing conditions. See Approved Materials List.
5. As an alternative, the enclosure can be 12" dia. x 24" high.
6. On roads without curbs, air valve assembly shall be located within the road right of way, one foot clear from the property line unless otherwise indicated on the plans. Air valve assembly shall be constructed on a 28" square concrete pad.

APPROVED BY:
GSWC STANDARDS COMMITTEE

Alison Sweet

EDC MANAGER

6/15/26
DATE



Golden State
Water Company

A Subsidiary of American States Water Company

TITLE:

2-INCH COMPACT STYLE COMBINATION
AIR RELEASE & VACUUM VALVE

SCALE:
NONE

DATE:
11/03/25

REV
2026

STANDARD DWG NO.
P-17

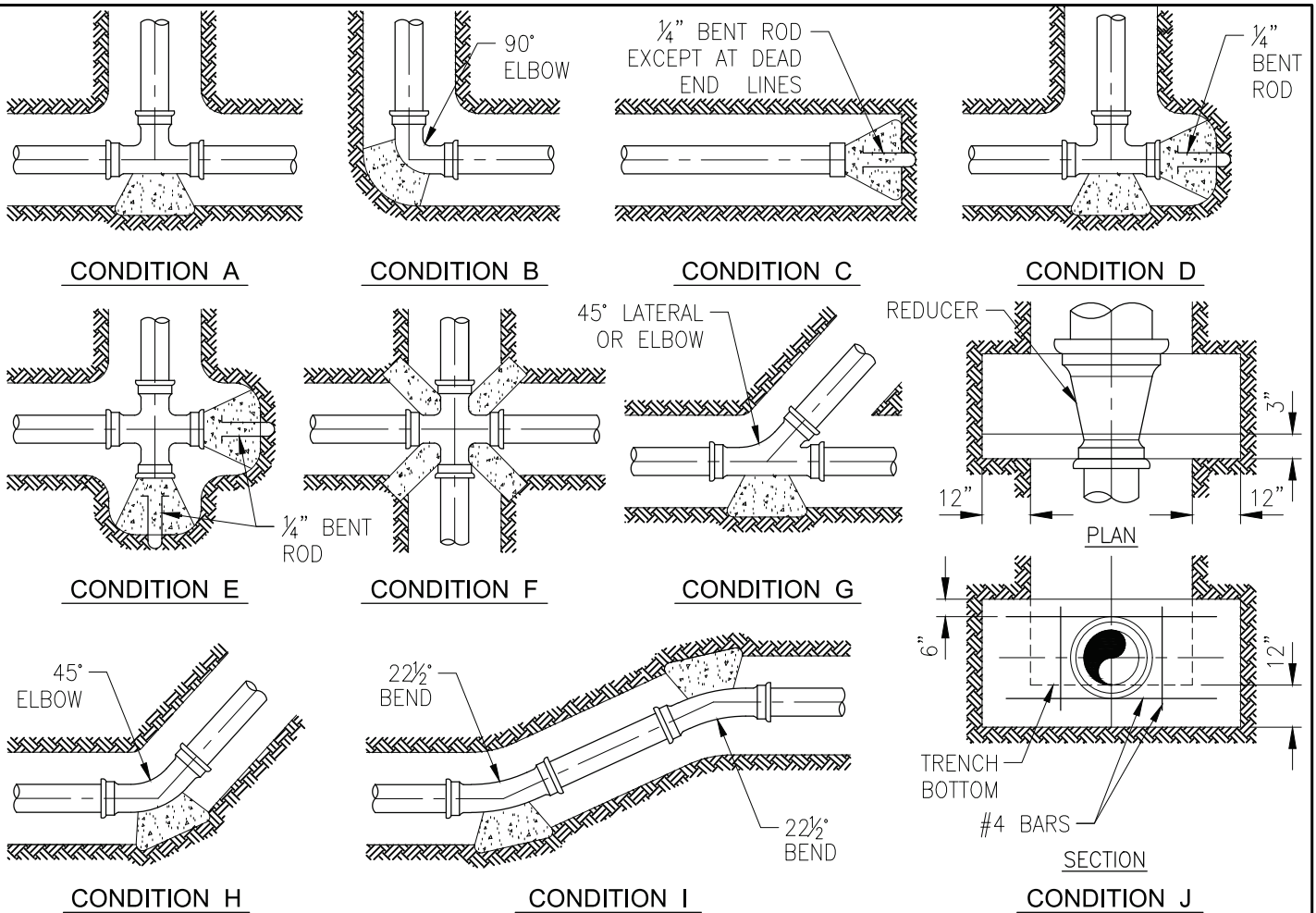

NOTES:

1. All buried bolts shall be coated with "Bitumastic No. 50" or approved equal.
2. Thrust block areas based on 225 PSI pressure and 2,000 PSF allowable soil pressure with 2½ feet of cover minimum. Additional bearing area required for poor soil conditions and shall be approved by the GSWC engineer.
3. Thrust block bearing faces shall be placed against undisturbed soil, approved compacted backfill or class 100-E-100 slurry.
4. Thrust blocks shall be 560-C-3250 concrete, unless specified otherwise.
 - A. Install ¼" bend rod handles.
 - B. Use cardboard separators between blocks, if needed.

THRUST BLOCK BEARING AREA IN SQUARE FEET

PIPE SIZE	DESCRIPTION									
	A	B	C	D	E	F	G	H	I	J
4"	3.1	4.3	3.1	2 @ 3.1	2 @ 3.1	4 @ 1.2	2.3	2.3	2 @ 1.2	8.0
6"	6.3	8.9	6.3	2 @ 6.3	2 @ 6.3	4 @ 2.5	4.8	4.8	2 @ 2.5	9.0
8"	10.9	15.4	10.9	2 @ 10.9	2 @ 10.9	4 @ 4.2	8.3	8.3	2 @ 4.2	10.1
10"	16.3	28.1	16.3	2 @ 16.3	2 @ 16.3	4 @ 6.4	12.5	12.5	2 @ 6.4	11.3
12"	23.1	32.7	23.1	2 @ 23.1	2 @ 23.1	4 @ 9.0	17.7	17.7	2 @ 9.0	12.5
14"	31.0	43.9	31.0	2 @ 31.0	2 @ 31.0	4 @ 12.1	23.8	23.8	2 @ 12.1	13.8
16"	40.1	56.7	40.1	2 @ 40.1	2 @ 40.1	4 @ 15.7	30.7	30.7	2 @ 15.7	15.1
20"	61.8	87.5	61.8	2 @ 61.8	2 @ 61.8	4 @ 24.1	47.3	47.3	2 @ 24.1	17.7
24"	88.2	124.8	88.2	2 @ 88.2	2 @ 88.2	4 @ 34.4	67.5	67.5	2 @ 34.4	20.3

APPROVED BY:
GSWC STANDARDS COMMITTEE

Alison Sweet
EDC MANAGER

6/15/26
DATE



Golden State
Water Company
A Subsidiary of American States Water Company

TITLE:

STANDARD THRUST BLOCK

SCALE: NONE	DATE: 11/03/25	REV: 2026	STANDARD DWG NO. P-18
----------------	-------------------	--------------	--------------------------

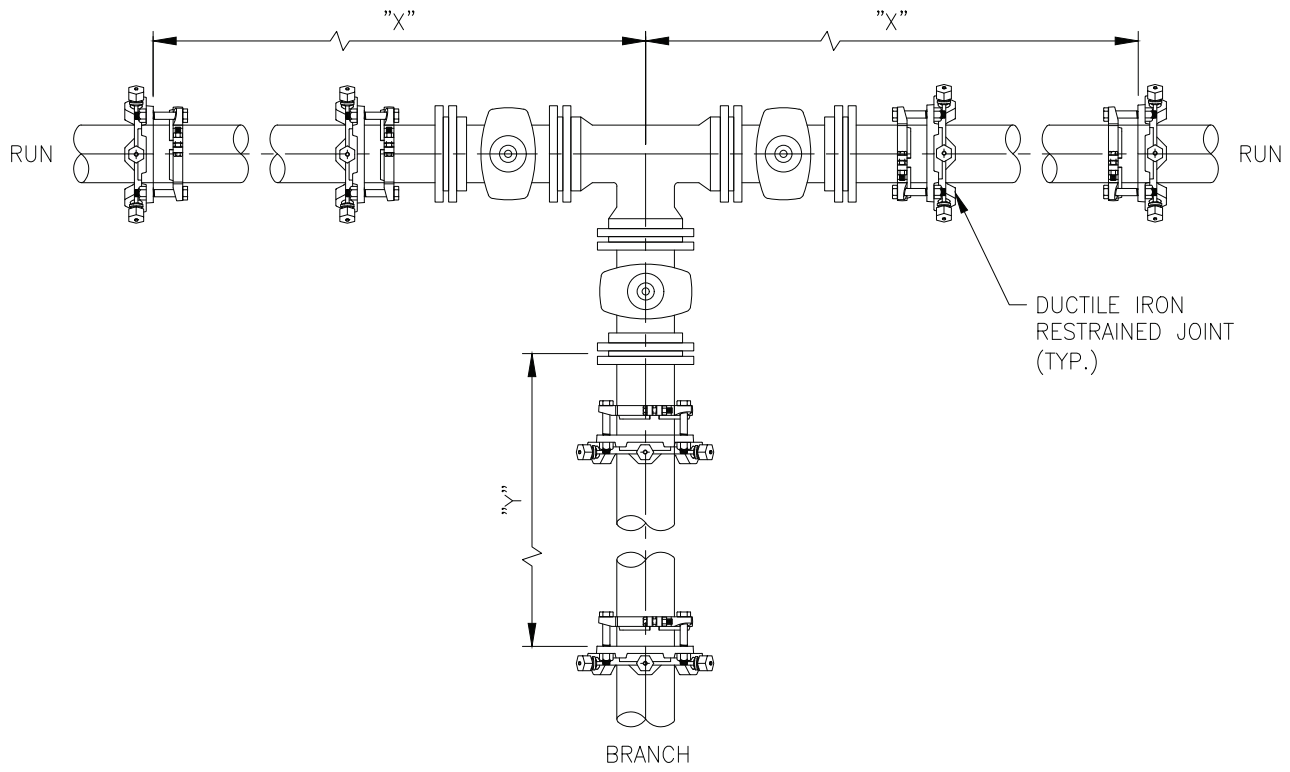

"X" PIPE LENGTH

	4	6	8	12	16	18	20	24
4	100	100	100	120	150	150	150	150
6	X	120	120	150	150	150	150	150
8	X	X	191	169	169	169	169	169
12	X	X	X	240	240	240	240	240
16	X	X	X	X	309	309	309	309
18	X	X	X	X	X	342	342	342
20	X	X	X	X	X	X	374	374
24	X	X	X	X	X	X	X	438

RESTRAINED LENGTH IN FEET

NOTES:

- "X" and "Y" shall be determined by length values using the DIPRA design method if conditions differ from assumptions given on Std. Dwg. No. P-21.
- If actual conditions differ from those listed above or the required restrained length cannot be met, the restrained length shall be determined by the design engineer and concurred with the GSWC engineer.

APPROVED BY:
 GSWC STANDARDS COMMITTEE

 EDC MANAGER
 6/15/26
 DATE



TITLE:
 RESTRAINT OF JOINTS FOR
 DUCTILE IRON & PVC PIPE
 AT TEE CONNECTION

SCALE: NONE	DATE: 02/23/26	REV 2026	STANDARD DWG NO. P-19
----------------	-------------------	-------------	--------------------------

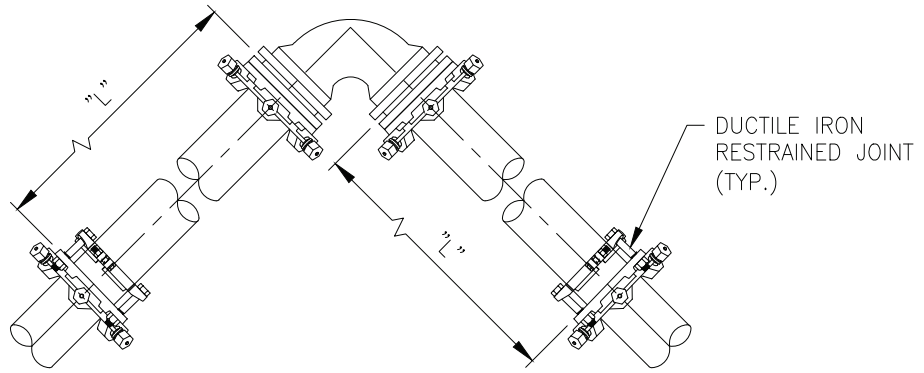

		PIPE SIZE							
		4	6	8	12	16	18	20	24
BEND ANGLE	11.25°	3	5	6	7	9	10	11	13
	22.5°	7	9	12	15	19	21	23	26
	45°	14	19	25	31	39	49	47	54
	90°	33	45	59	74	94	104	113	131

RESTRAINED LENGTH "L" IN FEET

HORIZONTAL BEND

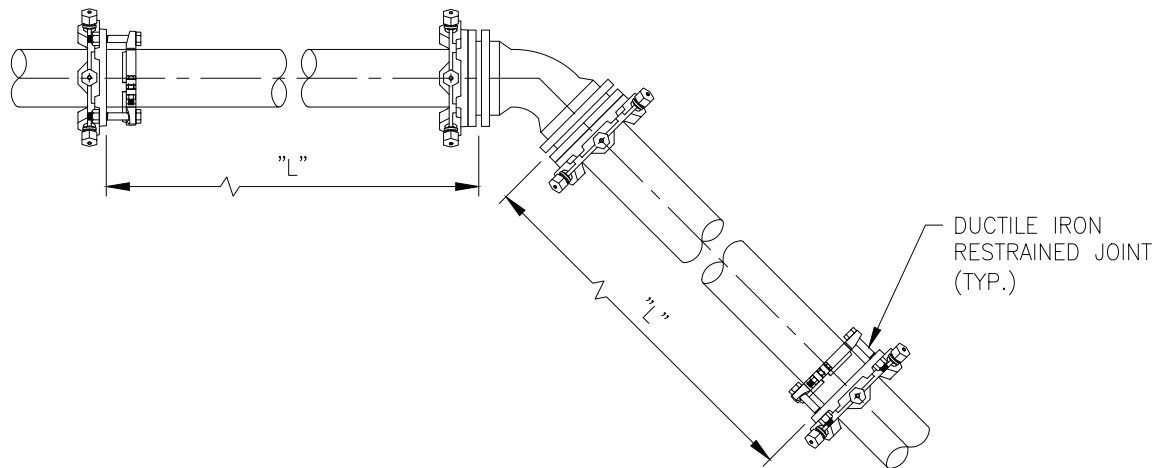

		PIPE SIZE							
		4	6	8	12	16	18	20	24
BEND ANGLE	11.25°	10	15	19	24	30	34	37	43
	22.5°	21	29	38	48	61	66	74	87
	45°	43	61	79	100	128	142	155	181

RESTRAINED LENGTH "L" IN FEET

VERTICAL BEND

NOTES:

1. If actual conditions differ from those listed above or the required restrained length cannot be met, the restrained length shall be determined by the design engineer and concurred with the GSWC engineer.

APPROVED BY:
GSWC STANDARDS COMMITTEE

Alison Sweet

EDC MANAGER

6/15/26
DATE



Golden State
Water Company

A Subsidiary of American States Water Company

TITLE: RESTRAINT OF JOINTS FOR
DUCTILE IRON & PVC PIPE
AT 90-DEGREE HORIZONTAL OR VERTICAL
BENDS

SCALE:	DATE:	REV	STANDARD DWG NO.
NONE	02/23/26	2026	P-20

DUCTILE IRON
RESTRAINED JOINT
(TYP.)

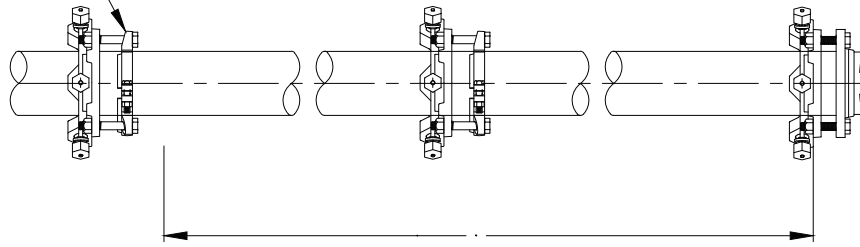

PIPE SIZE IN INCHES	4	6	8	12	16	18	20	24
RESTRAINED LENGTH "L" IN FEET	104	148	191	240	309	342	374	438

DEAD END

NOTES:

(Use for Std. Dwg. NO. P-19, P-20, & P-21)

1. All joint within length "L" shall be restrained.
2. Assumed Depth of cover for 8" pipe or less to be 3.5' min. (42"); 16" pipe or greater to be 4.0' min. (48").
3. Assumptions for determining length shown:
 - Test pressure: 225 psi
 - Type 4 laying conditions
 - A safety factor of 2
 - Sand/silt soil conditions
 - Polyethylene wrap
4. Length calculated using DIPRA restrained joint program.
5. If actual conditions differ from those listed above or the required restrained length cannot be met, the restrained length shall be determined by the design engineer and concurred with the GSWC engineer.

APPROVED BY:
GSWC STANDARDS COMMITTEE

Alison Sweet

EDC MANAGER

6/15/26
DATE



Golden State
Water Company

A Subsidiary of American States Water Company

TITLE: RESTRAINT OF JOINTS FOR
DUCTILE IRON AND PVC PIPE
AT A DEAD END OR EACH SIDE OF
VALVE

SCALE:	DATE:	REV	STANDARD DWG NO.
NONE	11/04/25	2026	P-21

STEEL PIPE WITH MINIMUM
PLATE THICKNESS AND
MINIMUM INSIDE DIAMETER
PER SCHEDULE HEREON
(SEE NOTE 9)

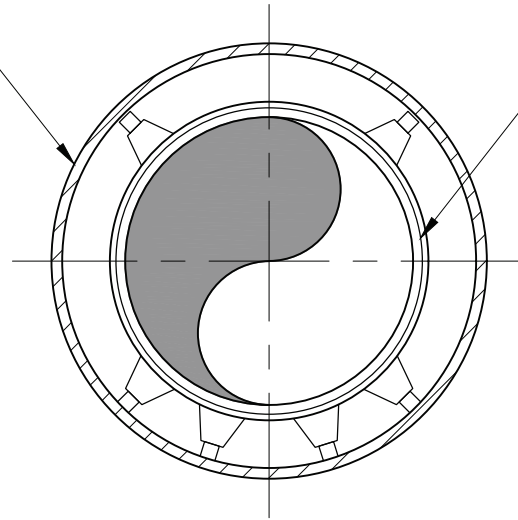

CARRIER PIPE CENTERED
IN CASING

CASING SCHEDULE

NOMINAL PIPE SIZE	NOMINAL CASING SIZE	MINIMUM WALL THICKNESS	
		OPEN TRENCH	JACK AND BORE
8"	16" I.D.	1/4"	3/8"
12"	20" I.D.	5/16"	1/2"
16"	30" I.D.	3/8"	1/2"
18"	32" I.D.	3/8"	1/2"
20"	36" I.D.	3/8"	1/2"
24"	42" I.D.	1/2"	1/2"
30"	48" I.D.	1/2"	5/8"
36"	56" I.D.	5/8"	3/4"
42"	60" I.D.	3/4"	7/8"

NOTES:

1. For PVC carrier pipe, use polyethylene casing insulators with polyethylene skids.
2. For ductile iron carrier pipe, use stainless steel band spacers and insulators with glass filled polymer plastic runners.
3. All casing insulators shall be designed by the manufacturer for application given the particular carrier pipe O.D. and casing pipe I.D.
4. All bolts and bands shall be Type 304 stainless steel.
5. Spacing between the casing insulators shall be per the manufacturers recommendations except that there shall be at least 4 casing insulators per pipe section, one 12" from each joint and two centered in between.
6. Both ends of the casing between the casing and carrier pipe must be sealed watertight using an end seal selected from the Approved Materials List. Bands shall be Type 304 stainless steel. Casing end seal shall be 1/4-inch thick styrene butadiene rubber.
7. All steel casing pipe joints shall be welded full circumference.
8. Materials shall be selected from the Approved Materials List.
9. HDPE casing may be used if it meets adequate strength for geotechnical conditions and with written approval from GSWC.

APPROVED BY:
GSWC STANDARDS COMMITTEE

Alison Sweet

EDC MANAGER

6/15/26
DATE



Golden State
Water Company

A Subsidiary of American States Water Company

TITLE:

CASING FOR
WATER MAINS

SCALE:
NONE

DATE:
02/23/26

REV
2026

STANDARD DWG NO.
P-22

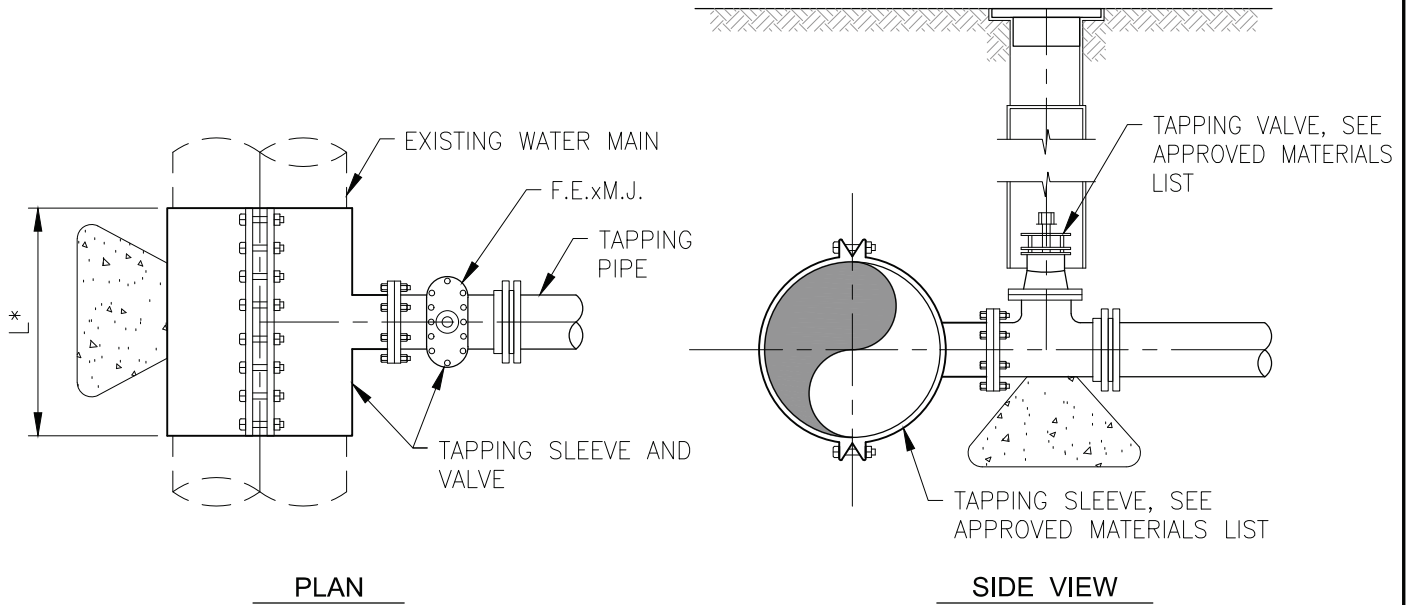

NOTES:

1. Tapping sleeve to be stainless steel per the Approved Materials List.
2. Tapping sleeve and valve are to be completely wrapped with 8 mil. polyethylene encasement.
3. After installation and before hot tap is complete, the tapping sleeve shall be tested at system pressure, for a minimum of 15 minutes with no visible leakage.
4. Tapping sleeve shall have a full length and width gasket. O-Ring gaskets are not acceptable.
5. Diameter of the hot tap shall be one pipe size smaller than the main line diameter. Size on size hot taps will require special approval by GSWC.
6. Tapping valve shall have a flange insulation kit between ductile iron valve and stainless steel tapping sleeve.

EXISTING WATER MAIN SIZE (INCHES)	TAPPING PIPE SIZE (INCHES)									
	4	6	8	10	12	14	16	18	20	24
4	X									
6	15	X								
8	15	15	X							
10	15	15	20	X						
12	15	15	20	20	X					
14	15	15	20	20	24	X				
16	16	16	20	20	24	24	X			
18	16	16	20	20	24	24	32	X		
20	16	16	20	20	24	24	32	36	X	
24	16	16	20	20	24	24	32	36	40	

L* = LENGTH OF TAPPING SLEEVE (INCHES)

APPROVED BY:
GSWC STANDARDS COMMITTEE

Alison Sweet

EDC MANAGER

6/15/26
DATE



Golden State
Water Company

A Subsidiary of American States Water Company

TITLE:

TAPPING SLEEVE AND VALVE

SCALE:
NONE

DATE:
11/03/25

REV
2026

STANDARD DWG NO.
P-23

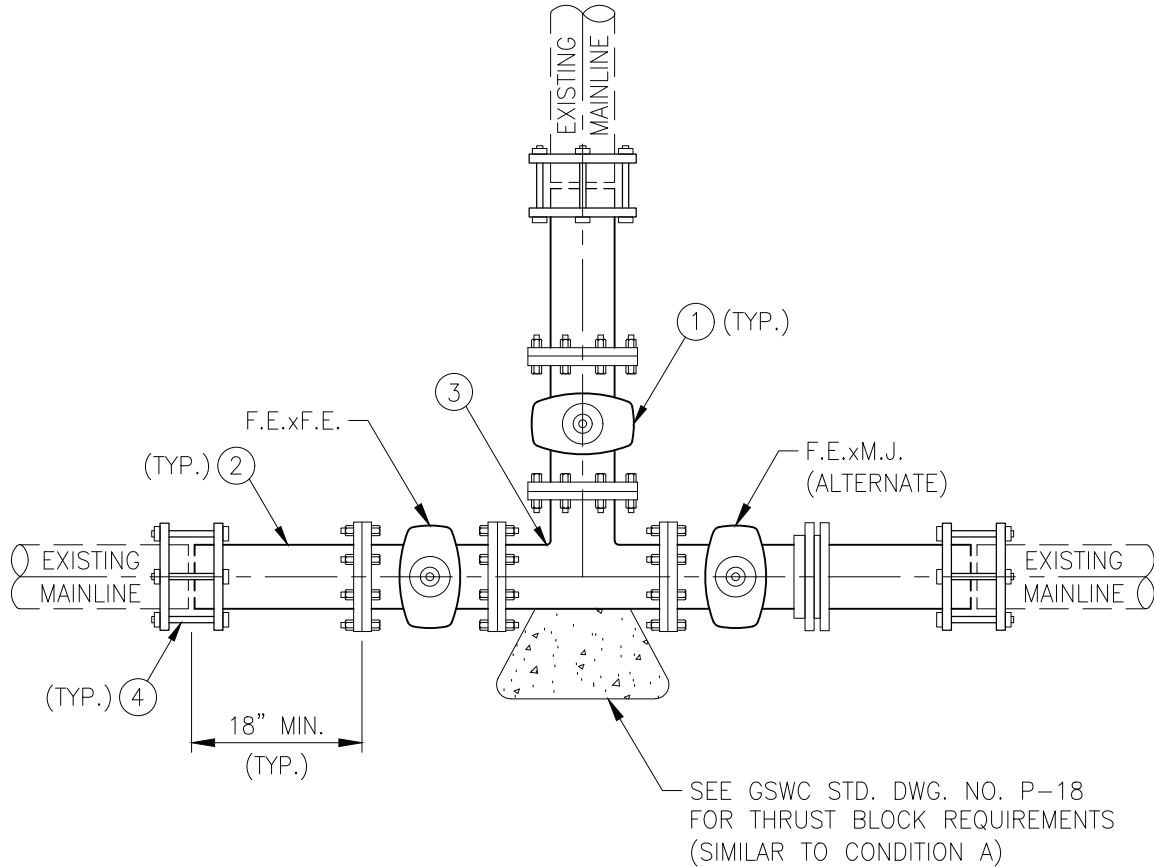

NOTES:

1. Cut-in tee may use F.E.xF.E. or F.E.xM.J. as called out on the drawings.
2. Use pipe material similar to existing mainline (PVC pipe shall be 3' min. length).

ITEM	DESCRIPTION
①	F.E.xF.E. (or F.E.xM.J.) gate valve per Approved Materials List.
②	D.I.P. F.E.xP.E. per Approved Materials List.
③	F.E.xF.E. tee per Approved Materials List.
④	Flexible coupling per Approved Materials List. For same size O.D. use Ductile Iron M.J. sleeve.

APPROVED BY:
GSWC STANDARDS COMMITTEE

Alison Sweet

EDC MANAGER

6/15/26
DATE



Golden State
Water Company

A Subsidiary of American States Water Company

TITLE:

CUT-IN TEE

SCALE:
NONE

DATE:
02/23/26

REV
2026

STANDARD DWG NO.
P-24

NEW SERVICE INSTALLATION NOTES:

- Meter box placement shall be per GSWC Std. Dwg. No. P-28 and/or as shown on plans. No meters shall be installed beyond limits of public right of way without easements, unless otherwise indicated on plans.
- Minimum separation between new service taps:

Service size 1	Service size 2	Minimum separation
2" or smaller	2" or smaller	3.0 feet
2" or smaller	3" or larger	3.0 feet
3" or larger	3" or larger	5.0 feet

Note: When installing consecutive 1" service taps, alternate saddles from 45 degrees to 22 degrees.

- For HDPE service lines, snake the service line in the trench to provide enough slack to allow at least one foot of thermal contraction per 100 feet of length. Attach tracer wire to HDPE service line.
- No joints permitted in service lines unless an elbow is used for the 2" water service connection.
- All new services shall be installed using service saddles.
- For $\frac{5}{8}$ " x $\frac{3}{4}$ " meter, use an A24 adapter. For $\frac{3}{4}$ " x $\frac{3}{4}$ " meter, use an A34 adapter.
- For a 1" angle meter valve, 1" copper pack joint x $\frac{3}{4}$ " meter nut may be utilized when specified on construction plans.
- Services shall be installed a minimum of 10 feet from all sewer laterals and proposed street tree or street light locations.
- In areas with corrosive soils use HDPE service lines with tracer wire.
- Use silver solder (lead free) for all copper service work.
- Applicant shall install backflow prevention assembly per requirements of GSWC's Cross-Connection Control Policy on all services as called for on the plans.
- Curb marking will be as allowed by the local governing agency.

REPLACEMENT HOUSELINE NOTES:

- Minimum size shall be no less than 1 inch.
- If the existing houseline is copper, it will be replaced with type K same size copper. If the existing houseline is standard galvanized or plastic, it will be replaced with HDPE or PVC SCH 80 unless the local building code specifies other material.
- There is to be no PVC above grade. Above grade pipe shall match customer's existing material. For bidding purposes contractor shall bid copper pipe with dielectric couplings.
- A gate valve will be installed on new houselines that bypasses an existing valve.
- Depth of houseline shall meet the requirements of the local plumbing code.
- Contractor will supply a list of materials used for each houseline and an as-built drawing of houseline installation.
- Contractor shall restore impacted areas to equal or better than condition prior to performing work.
- Curb marking will be as allowed by the local governing agency.

APPROVED BY:
GSWC STANDARDS COMMITTEE

Alison Sweet

EDC MANAGER

6/15/26
DATE



Golden State
Water Company

A Subsidiary of American States Water Company

TITLE:

WATER SERVICE
CONSTRUCTION NOTES

SCALE:
NONE

DATE:
11/03/25

REV
2026

STANDARD DWG NO.
P-25

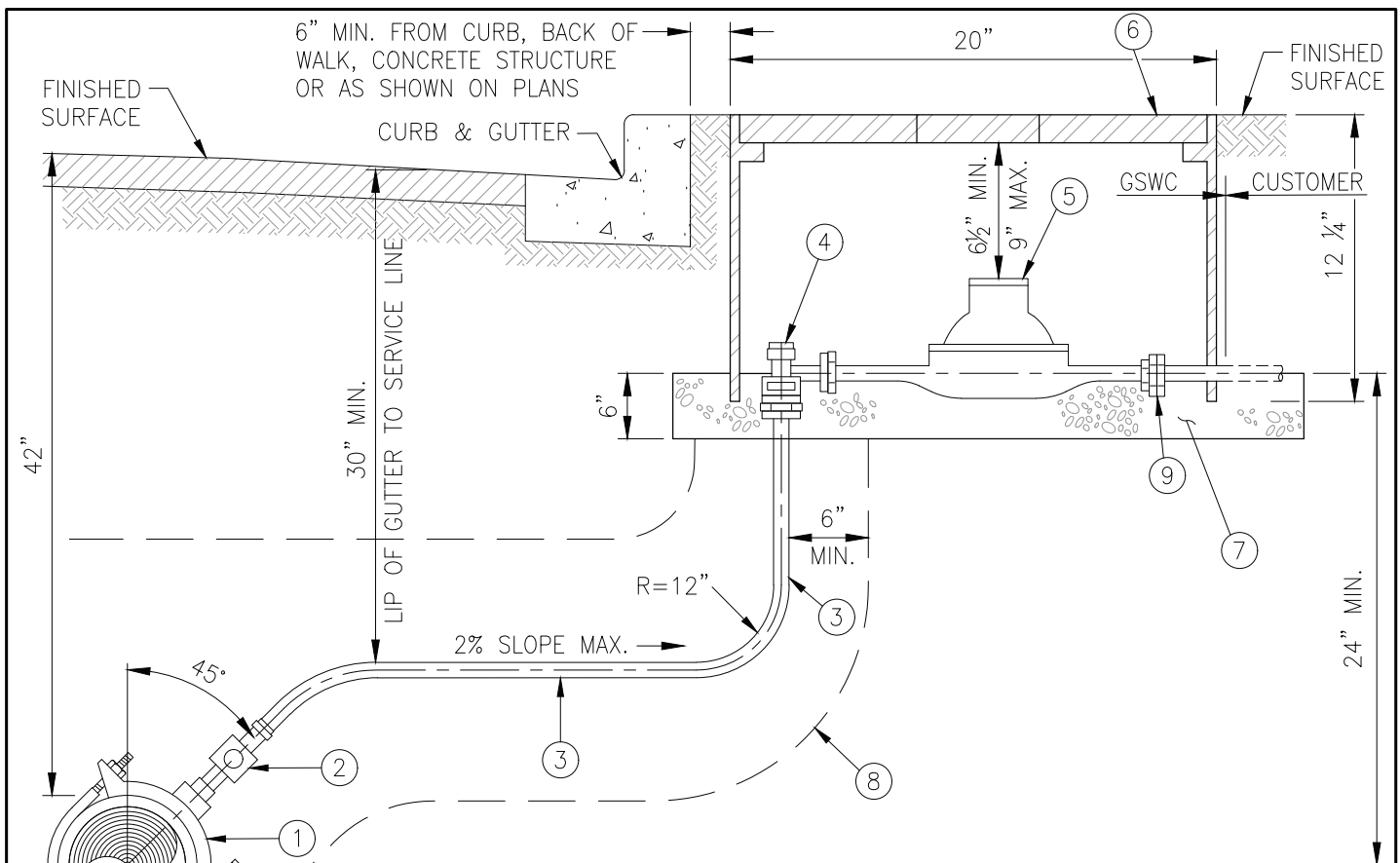

NOTES:

1. No water meter box shall be installed in driveway or sidewalk unless shown on the plans. Meter boxes shall be set to match surrounding grade or 2% slope to prevent water runoff into the box.
2. No service closer than 24 inches to pipe bell.
3. Water meters in Wrightwood shall be installed at a minimum depth of 30 inches below grade. Use 2 stacked water meter boxes over meter.
4. HDPE service line shall be installed with a tracer wire that will terminate with a 12" coil in the meter box.
5. GSWC may provide a meter spacer in lieu of a meter.
6. Meter box shall have one 3"x4" opening on one end of the box (customer side).

ITEM	EACH	DESCRIPTION	SPECIFICATION	REMARKS
①	1	Service saddle	Strap to be S.S. or bronze	See Approved Materials List
②	1	1" ball valve corp. stop	C.C. x C.T.S. compression	
③	1	Copper tubing or HDPE	1" Type K, soft	One piece only, no splices
④	1	1" angle meter stop (ball valve)	1" C.T.S. compression x meter lock wing w/ 1/8" thick cloth inserted in gasket	
⑤	1	Water meter	5/8", 3/4" or 1"	Supplied by GSWC; installed by contractor
⑥	1	Water meter box	12"x20" meter box	See Approved Materials List
⑦	1	Water meter box pad	14"x24"x6", 3/4" crushed rock	Pad for meter and box
⑧	1	Trench with sand envelope	Imported with SE > 30	12" min. & 24" max. trench width
⑨	1	Coupling	1" C.T.S. compression x F.I.P. thread	

APPROVED BY:
 GSWC STANDARDS COMMITTEE

 EDC MANAGER
 6/15/26
 DATE



TITLE:
1-INCH WATER SERVICE CONNECTION

SCALE: NONE	DATE: 11/13/25	REV: 2026	STANDARD DWG NO. P-26
----------------	-------------------	--------------	--------------------------

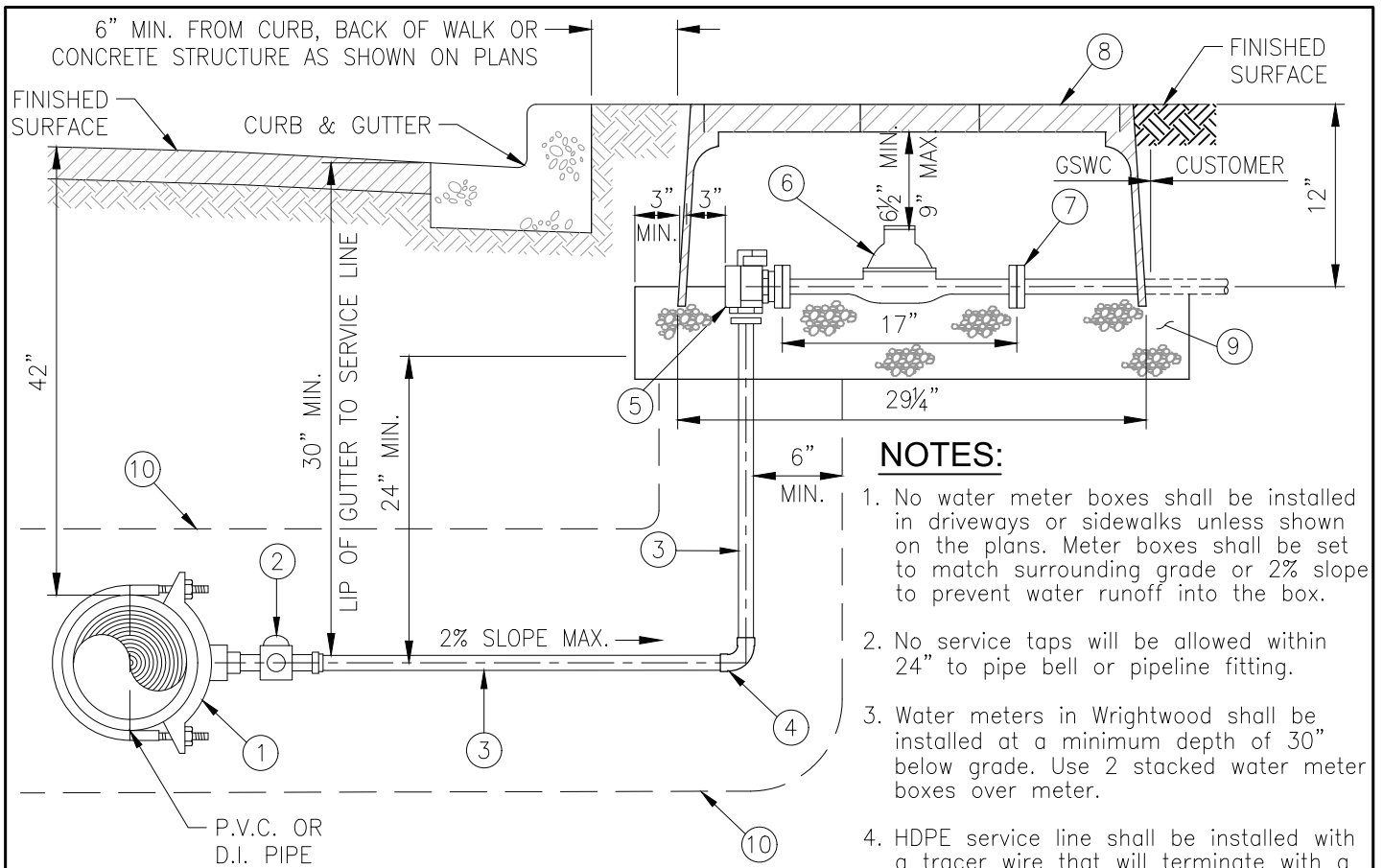

NOTES:

1. No water meter boxes shall be installed in driveways or sidewalks unless shown on the plans. Meter boxes shall be set to match surrounding grade or 2% slope to prevent water runoff into the box.
2. No service taps will be allowed within 24" to pipe bell or pipeline fitting.
3. Water meters in Wrightwood shall be installed at a minimum depth of 30" below grade. Use 2 stacked water meter boxes over meter.
4. HDPE service line shall be installed with a tracer wire that will terminate with a 12" coil in the meter box.
5. Flattening copper pipe is not allowed.
6. GSWC may provide a meter spacer in lieu of a meter.

ITEM	EACH	DESCRIPTION	SPECIFICATION	REMARKS
①	1	Service saddle	Strap to be S.S. or bronze	See Approved Materials List
②	1	2" bronze ball valve corp. stop	2" C.C. x C.T.S. compression	See Approved Materials List
③	2	Copper tubing or HDPE	2" Type K, soft	One piece only, no bends, unless elbow is used. Elbow joints to be silver soldered.
④	1	Elbow	2" C.T.S.	See Approved Materials List
⑤	1	Angle meter stop (ball valve)	2" C.T.S. compression x meter lock wing w/ 1/8" thick cloth inserted in gasket	1/8" thick cloth gasket at both meter flanges.
⑥	1	Water meter	2" flg meter	Supplied by GSWC; installed by contractor
⑦	1	Bronze water meter flange	2" F.I.P. threads w/ 1/8" thk cloth insert drop in gasket	
⑧	1	Water meter box	17"x30" meter box	See Approved Materials List
⑨	1	Water meter box pad	20"x34"x6", 3/4" crushed rock	Pad for meter box
⑩	1	Trench with sand envelope	Imported with SE > 30	12" min. & 24" max. trench width

APPROVED BY:
GSWC STANDARDS COMMITTEE

Alison Sweet
EDC MANAGER

6/15/26
DATE



Golden State
Water Company
A Subsidiary of American States Water Company

TITLE:

**2-INCH WATER
SERVICE CONNECTION**

SCALE: NONE	DATE: 11/14/25	REV: 2026	STANDARD DWG NO. P-27
----------------	-------------------	--------------	--------------------------

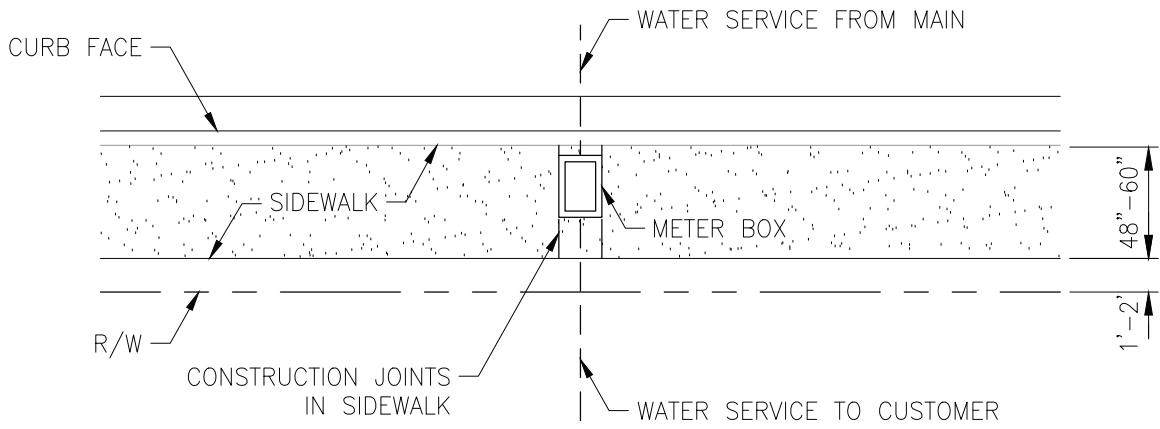

**CONDITION 1
IN THE SIDEWALK**

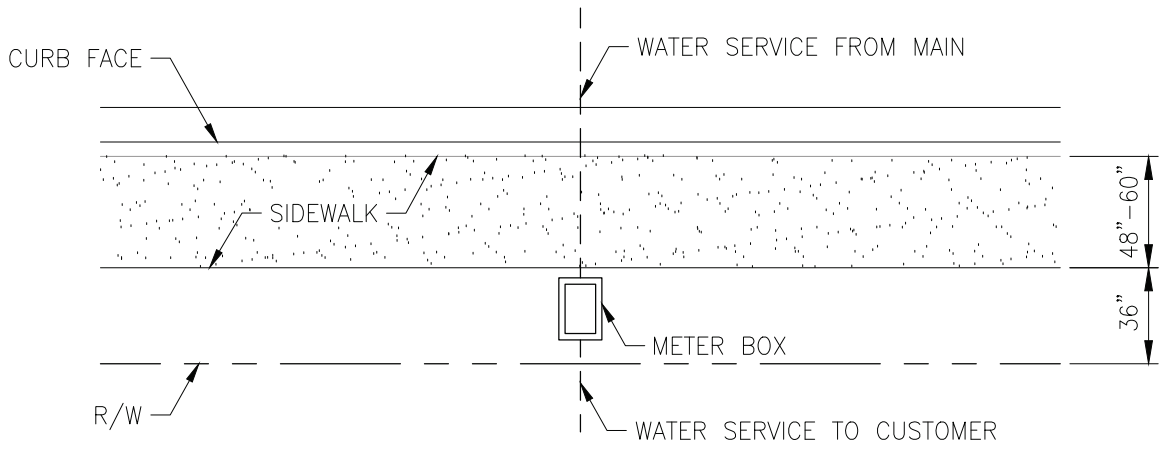

**CONDITION 2
BEHIND THE SIDEWALK**

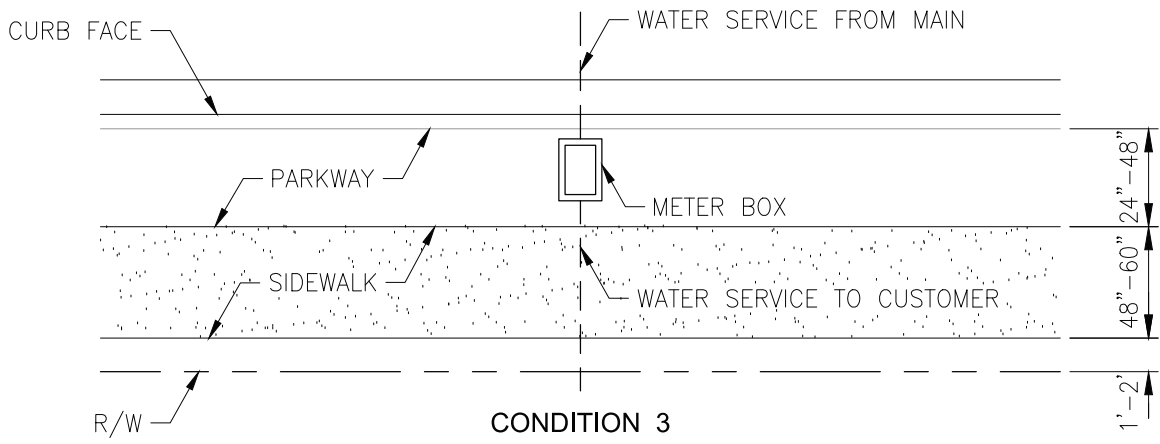

**CONDITION 3
IN THE PARKWAY**

NOTES:

1. Meter box size for 1" service will be 12"x20".
2. Meter box size for 2" service will be 17"x30".
3. For Meter Box Details see GSWC Std. Dwg. No. P-26 and P-27.
4. Location of meter box shall be called out on the plans by referencing this standard drawing.

APPROVED BY:
GSWC STANDARDS COMMITTEE

Alison Sweet

EDC MANAGER

6/15/26
DATE



**Golden State
Water Company**

A Subsidiary of American States Water Company

TITLE:

TYPICAL METER BOX LOCATION

SCALE:
NONE

DATE:
07/31/23

REV
2024

STANDARD DWG NO.
P-28

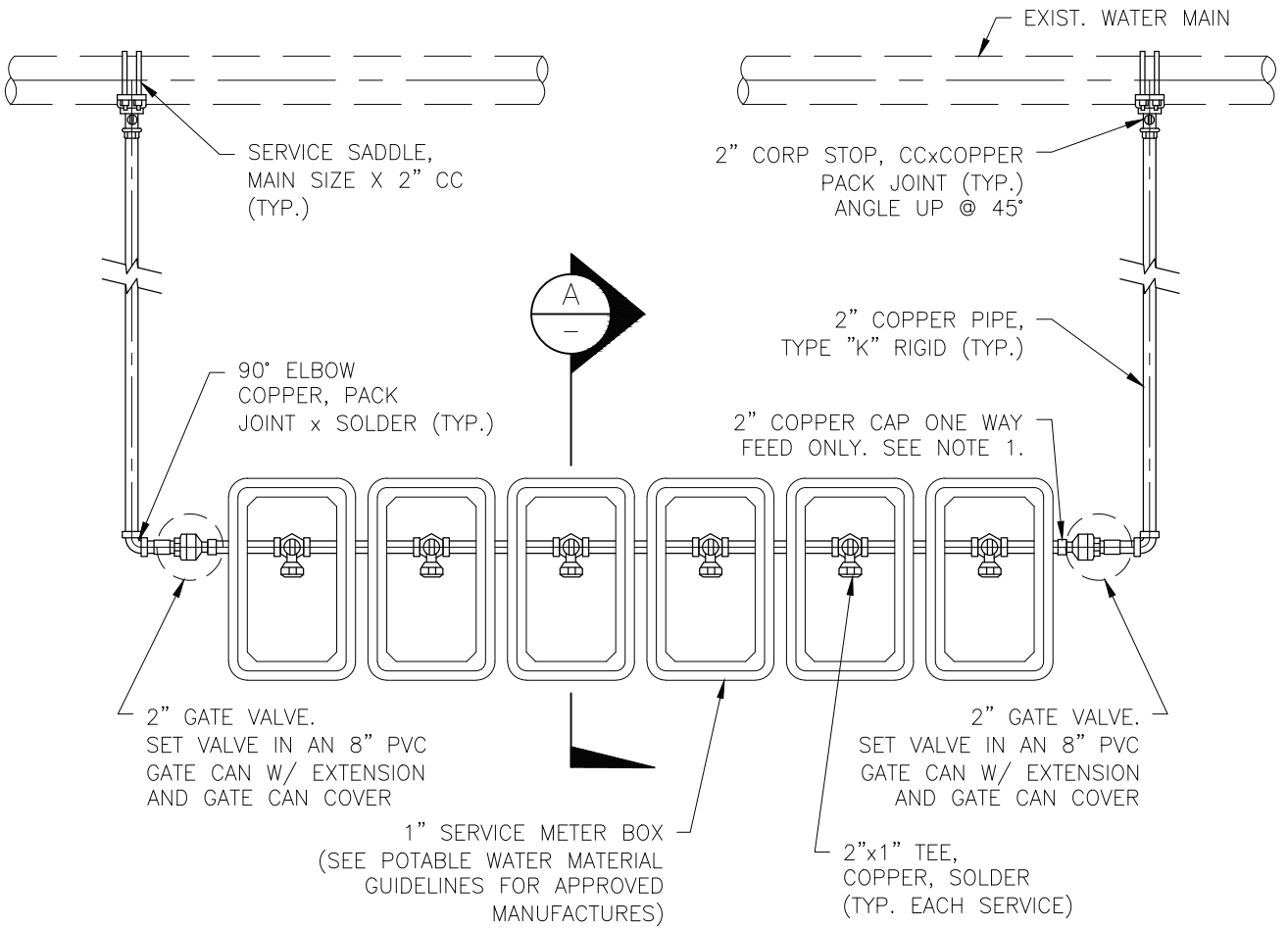

PLAN

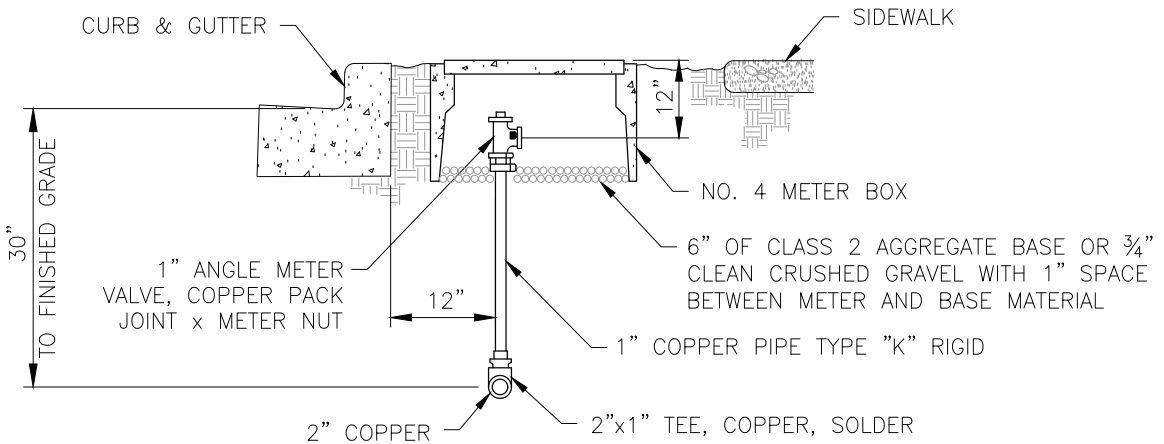

SECTION A

NOTE:

1. Two-way feed shall be provided where six or more services are to be installed. A maximum of fifteen services may be installed on one battery.
2. Meter boxes shall be located per GSWC Std. Dwg. No. P-28.

APPROVED BY:
GSWC STANDARDS COMMITTEE

Alison Sweet

EDC MANAGER

6/15/26
DATE



Golden State
Water Company

A Subsidiary of American States Water Company

TITLE:

**1-INCH GROUPED
DOMESTIC SERVICE CONNECTION**

SCALE:	DATE:	REV	STANDARD DWG NO.
NONE	11/03/25	2026	P-29

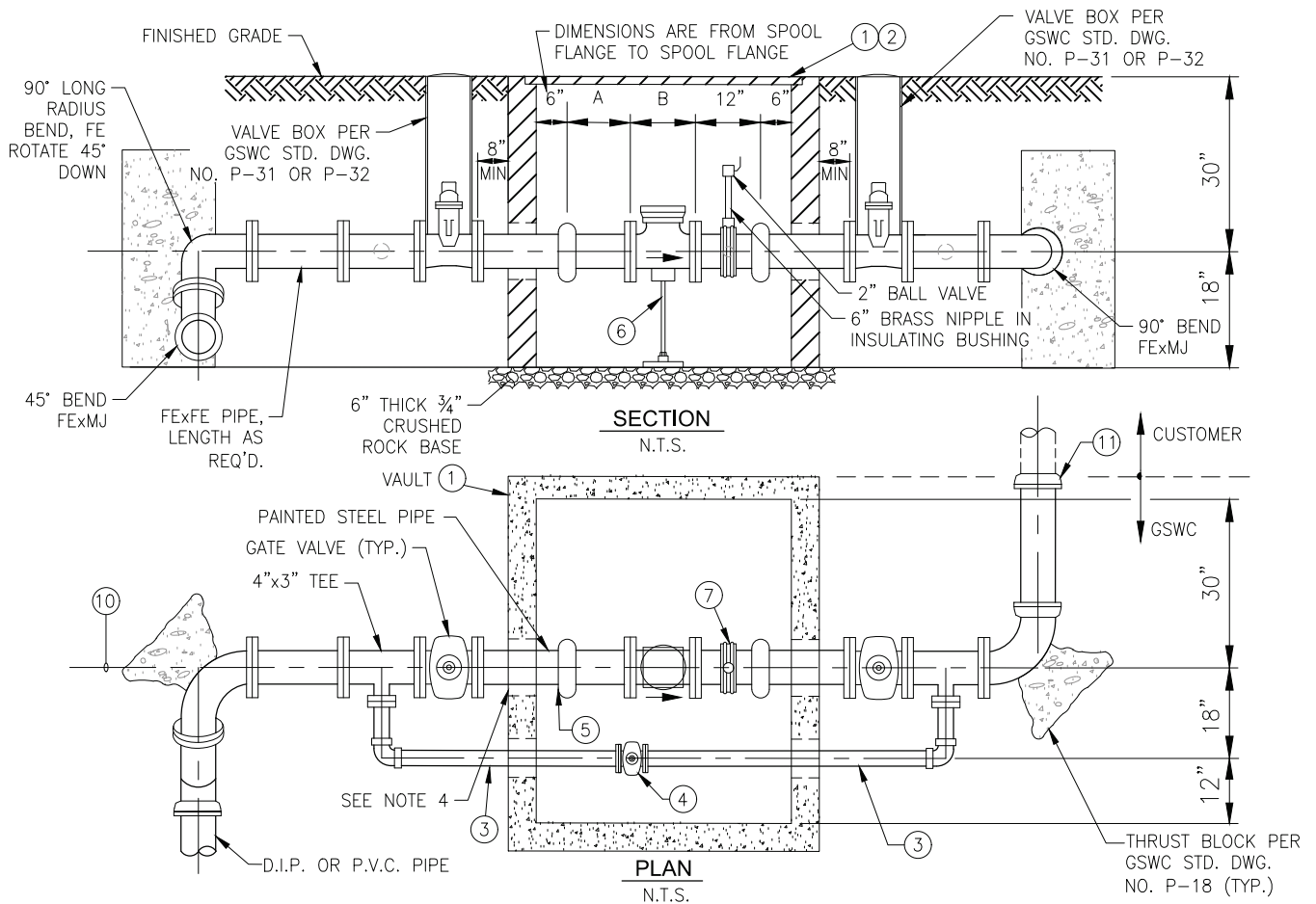

ITEM	DESCRIPTION
①	Non-traffic bearing 20K rated vault located behind curb and/or parkway, with open bottom. Lid shall be lockable, torsion spring assisted aluminum design for 10K loading. Use 20K rated vault and lid in traffic locations. See Approved Materials List for acceptable manufacturers and GSWC Std. Dwg. No. P-36 for vault details.
②	Alternate hatch cover: 3 piece steel bolt down traffic/parkway cover. See GSWC Std. Dwg. No. P-36.
③	Bypass piping shall be 3" wrapped and epoxy lined Sch. 80 steel or 3" wrapped and cement lined DI pipe.
④	Bypass shut off valve shall be epoxy lined gate valve for 3". Gate valve to have an operating nut lock.
⑤	Victaulic coupling shall be AWWA approved Style 31 for DI pipe or style 77 for steel pipe.
⑥	Pipe supports per GSWC Std. Dwg. No. C-2.
⑦	Service saddle with ball curb stop for meter testing. (Center in spool)
⑧	All dissimilar metals shall be insulated from each other by insulated flanges and/or bushings.
⑨	Install tracer wire from main to inside the vault.
⑩	Vault alignment piping parallels the right of way.
⑪	Install temporary MJ cap for testing. Cap to be removed by developer after project has been completed.

VAULT DESCRIPTION					
PIPE/METER SIZE	A (UPSTREAM SPOOL)	B (METER)	VAULT SIZE	FLOW RANGE (GPM)	BYPASS PIPE
4"	7"	14"	4'x4'	1½-1,000	3"
6"	12"	18"	4'x4'	3-1,600	4"
8"	16"	20"	4'x5'	5-2,800	4"
10"	20"	18"	4'x5'	14-5,500	6"

NOTE:

1. Bypass piping not required for irrigation services.
2. Ultra sonic meter shall be of a type approve by N.S.F., F.M. and A.W.W.A.
3. Ultra sonic meter body shall be Type 316 stainless steel or epoxy coated ductile iron.
4. See GSWC Std. Dwg. No. P-37 for sealing of pipe openings.
5. All pipes on both sides of vault shall be fully restrained.

APPROVED BY:
GSWC STANDARDS COMMITTEE

Alison Sweet

EDC MANAGER

6/15/26
DATE



Golden State
Water Company

A Subsidiary of American States Water Company

TITLE:

LARGE METER WITH BYPASS
(4-INCH AND LARGER METER)

SCALE:	DATE:	REV	STANDARD DWG NO.
NONE	02/10/26	2026	P-30A

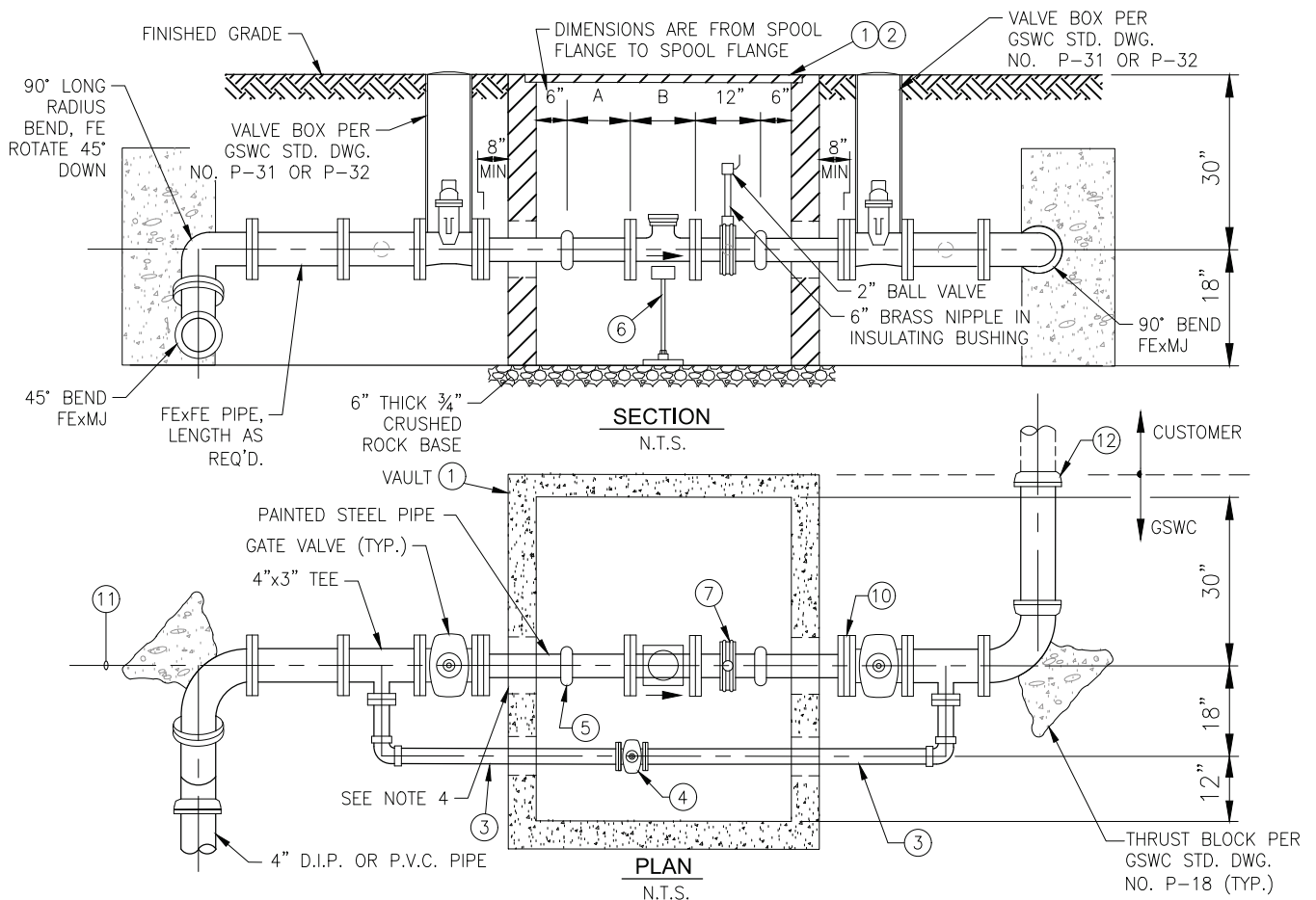

ITEM	DESCRIPTION
①	Non-traffic bearing 20K rated vault located behind curb and/or parkway, with open bottom. Lid shall be lockable, torsion spring assisted aluminum design for 10K loading. Use 20K rated vault and lid in traffic locations. See Approved Materials List for acceptable manufacturers and GSWC Std. Dwg. No. P-36 for vault details.
②	Alternate hatch cover: 3 piece steel bolt down traffic/parkway cover. See GSWC Std. Dwg. No. P-36.
③	Bypass piping shall be 3" wrapped and epoxy lined Sch. 80 steel or 3" wrapped and cement lined DI pipe.
④	Bypass shut off valve shall be epoxy lined gate valve for 3". Gate valve to have an operating nut lock.
⑤	Victaulic coupling shall be AWWA approved Style 31 for DI pipe or style 77 for steel pipe.
⑥	Pipe supports per GSWC Std. Dwg. No. C-2.
⑦	Service saddle with ball curb stop for meter testing. (Center in spool)
⑧	All dissimilar metals shall be insulated from each other by insulated flanges and/or bushings.
⑨	Install tracer wire from main to inside the vault.
⑩	Reducing flange (4"x3") as manufactured by Redhed, MFG., or approved equal. (Typ of 2)
⑪	Vault alignment piping parallels the right of way.
⑫	Install temporary MJ cap for testing. Cap to be removed by developer after project has been completed.

VAULT DESCRIPTION					
PIPE/METER SIZE	A (UPSTREAM SPOOL)	B (METER)	VAULT SIZE (ID)	FLOW RANGE (GPM)	BYPASS PIPE
4"/3"	As Req'd	12"	4'x5'	1-500	3"

NOTE:

1. Bypass piping not required for irrigation services.
2. Ultra sonic meter shall be of a type approve by N.S.F., F.M. and A.W.W.A.
3. Ultra sonic meter body shall be Type 316 stainless steel or epoxy coated ductile iron.
4. See GSWC Std. Dwg. No. P-37 for sealing of pipe openings.
5. All pipes on both sides of vault shall be fully restrained.

4" SERVICE WITH 3" METER AND BYPASS IN 4'x5' VAULT

N.T.S.

APPROVED BY:
GSWC STANDARDS COMMITTEE

Alison Sweet

EDC MANAGER

6/15/26
DATE



Golden State
Water Company

A Subsidiary of American States Water Company

TITLE:

LARGE METER WITH BYPASS
(3-INCH METER)

SCALE:	DATE:	REV	STANDARD DWG NO.
NONE	02/10/26	2026	P-30B

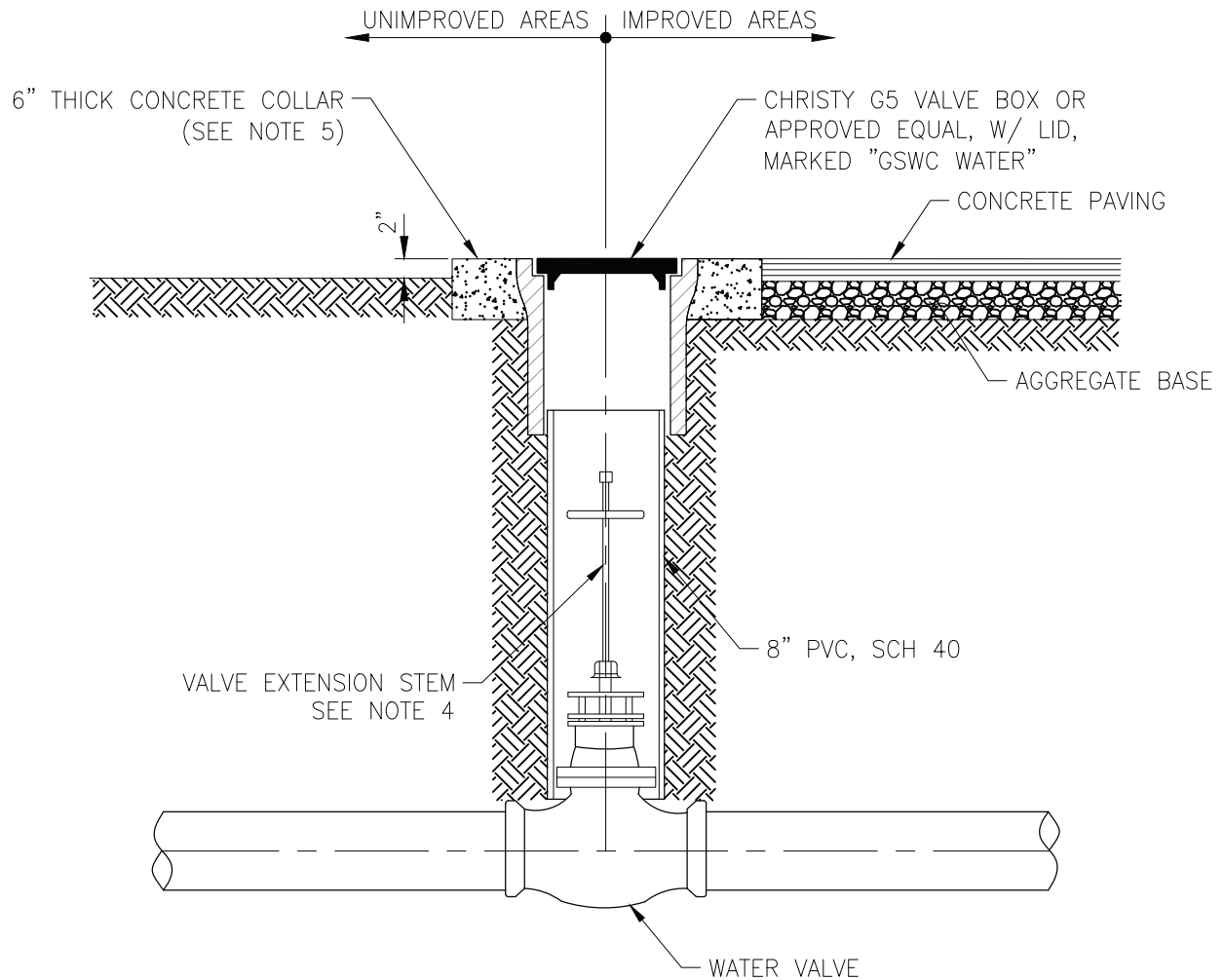

NOTES:

1. The following valve box types shall be used unless otherwise noted:
 Type 1 – Unimproved areas, concrete surfaced streets, concrete pads, or as called out on the plans.
 Type 3 – All other locations as called out on the plans.
2. Final rim elevation to be 1/8" to 1/4" below final street grade.
3. More stringent installation requirements may be imposed by the entity having the jurisdiction over the valve box installation location.
4. A valve extension stem shall be provided where the depth to the operating nut exceeds 4 feet.
5. Contractor to form 18 inch diameter concrete collar in unimproved areas with sonotube and remove prior to backfill installation (typ).
6. See Approved Materials List for all approved products.
7. For paving around valves not in the pavement, see GSWC Std. Dwg. No. C-12.
8. Install pavement markers on curb face nearest to valve.

APPROVED BY:
 GSWC STANDARDS COMMITTEE

Alison Sweet
 EDC MANAGER

6/15/26
 DATE



Golden State
 Water Company
 A Subsidiary of American States Water Company

TITLE:

VALVE BOX
 TYPE 1

SCALE: NONE	DATE: 11/14/25	REV: 2026	STANDARD DWG NO. P-31
----------------	-------------------	--------------	--------------------------

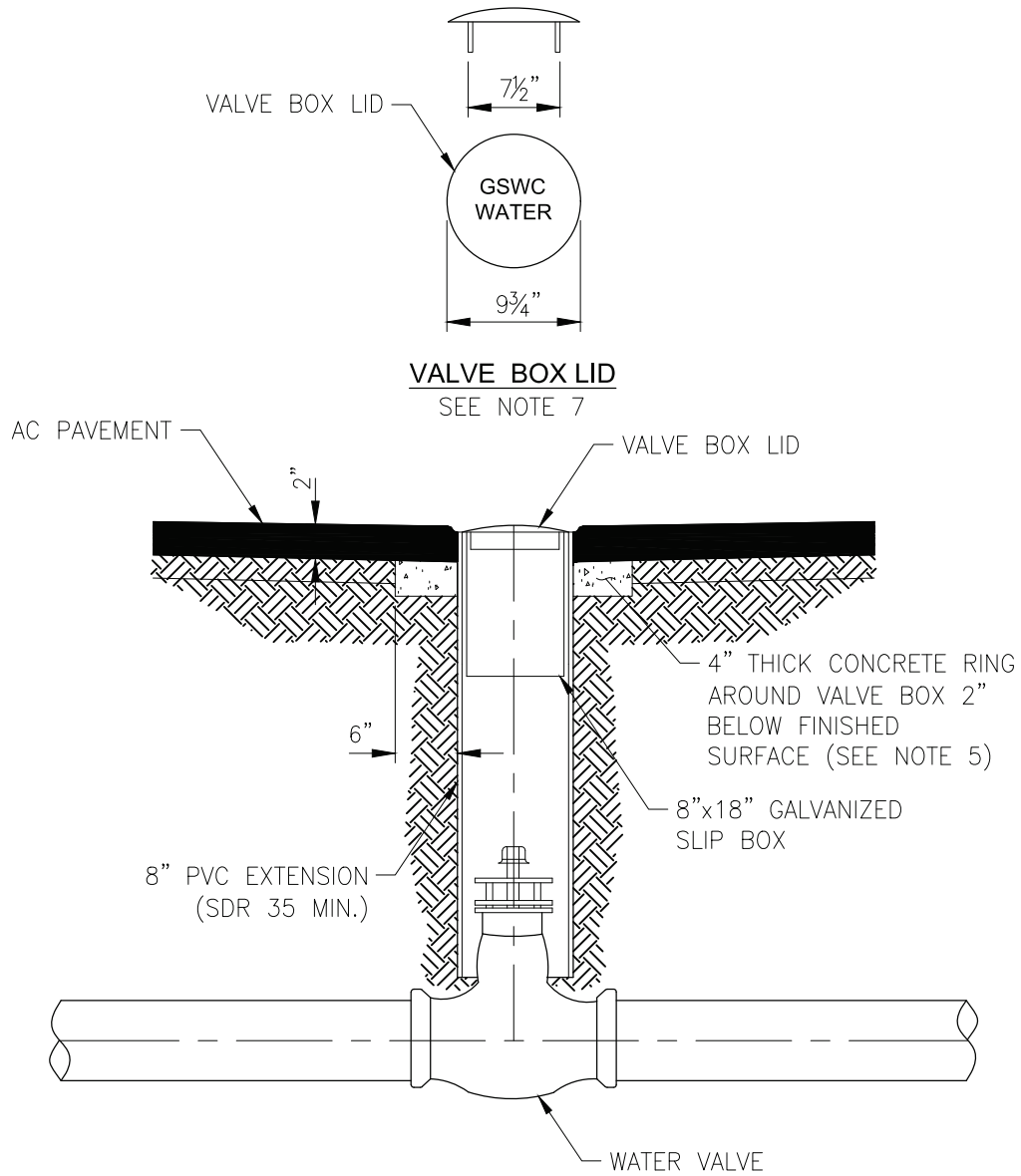

NOTES:

1. The following valve box types shall be used unless otherwise noted:
 Type 1 – Unimproved areas, concrete surfaced streets or pads or as called out on the plans.
 Type 3 – All other locations as called out on the plans.
2. Final rim elevation to be $\frac{1}{8}$ " to $\frac{1}{4}$ " below final street grade.
3. More stringent installation requirements may be imposed by the entity having the jurisdiction over the valve box installation location.
4. A valve extension stem shall be provided where the depth to the operating nut exceeds 4 feet.
5. Contractor to form 18 inch diameter concrete collar in unimproved areas with sonotube and remove sonotube prior to backfill installation (typ).
6. See Approved Materials List for all approved products.
7. For paving around valves not in the pavement, see GSWC Std. Dwg. No. C-12.

APPROVED BY:
 GSWC STANDARDS COMMITTEE

Alison Sweet

EDC MANAGER

6/15/26
 DATE



Golden State
 Water Company

A Subsidiary of American States Water Company

TITLE:

VALVE BOX
 TYPE 3

SCALE:	DATE:	REV	STANDARD DWG NO.
NONE	02/23/26	2026	P-32

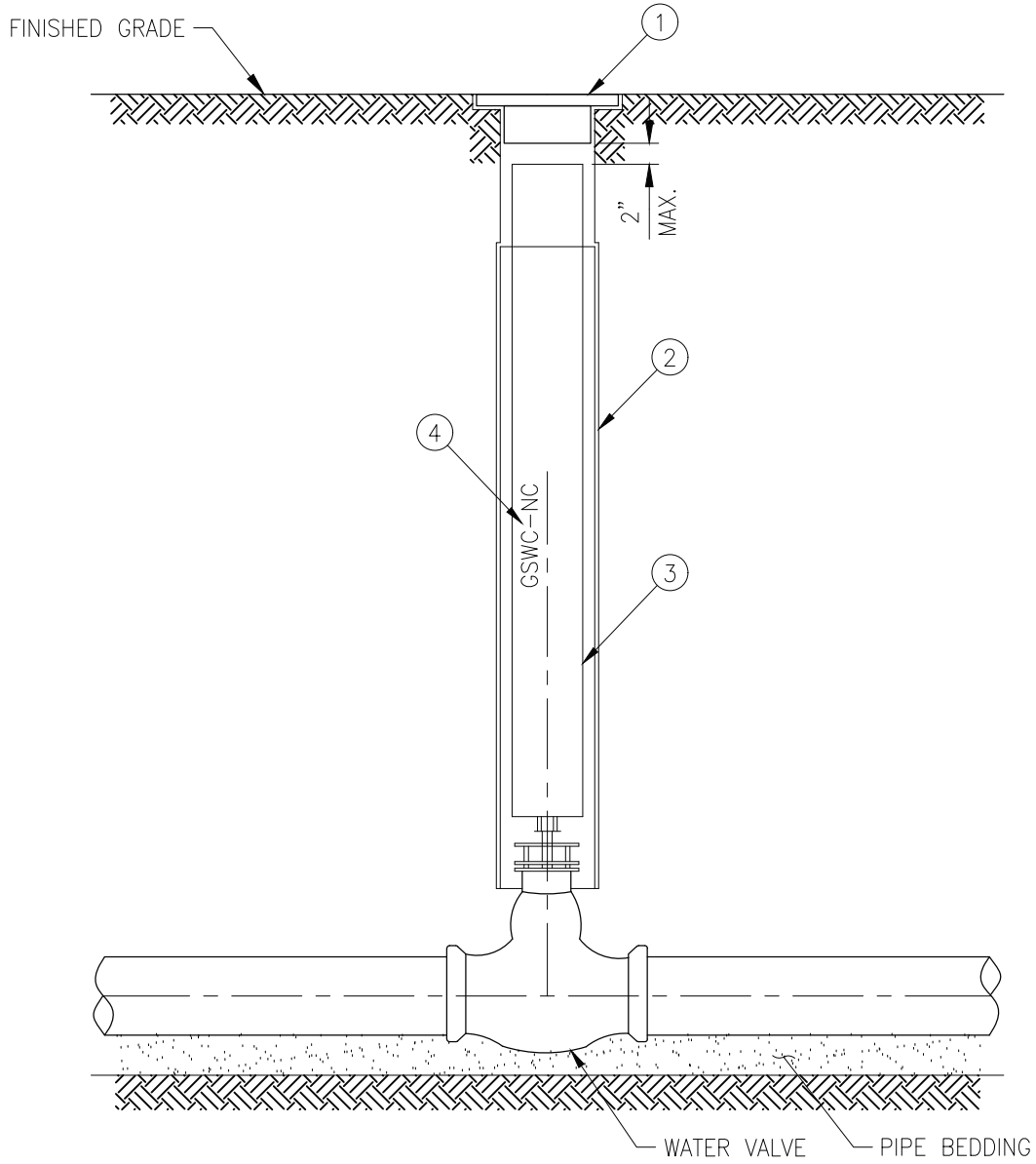

ITEM	DESCRIPTION
①	Valve box per GSWC Std. Dwg. No. P-31 or P-32
②	PVC Valve box
③	4"x4" redwood post
④	Route initials "GSWC-NC" for (normally closed) on all sides in 1½" high letters, ½" deep, clearly legible or security attach 1½" high brass label on all four sides engraved with "GSWC-NC"

APPROVED BY:
GSWC STANDARDS COMMITTEE

Alison Sweet

EDC MANAGER

6/15/26
DATE



Golden State
Water Company

A Subsidiary of American States Water Company

TITLE:

**NORMALLY CLOSED
VALVE BOX**

SCALE:
NONE

DATE:
07/23/24

REV
2024

STANDARD DWG NO.
P-33

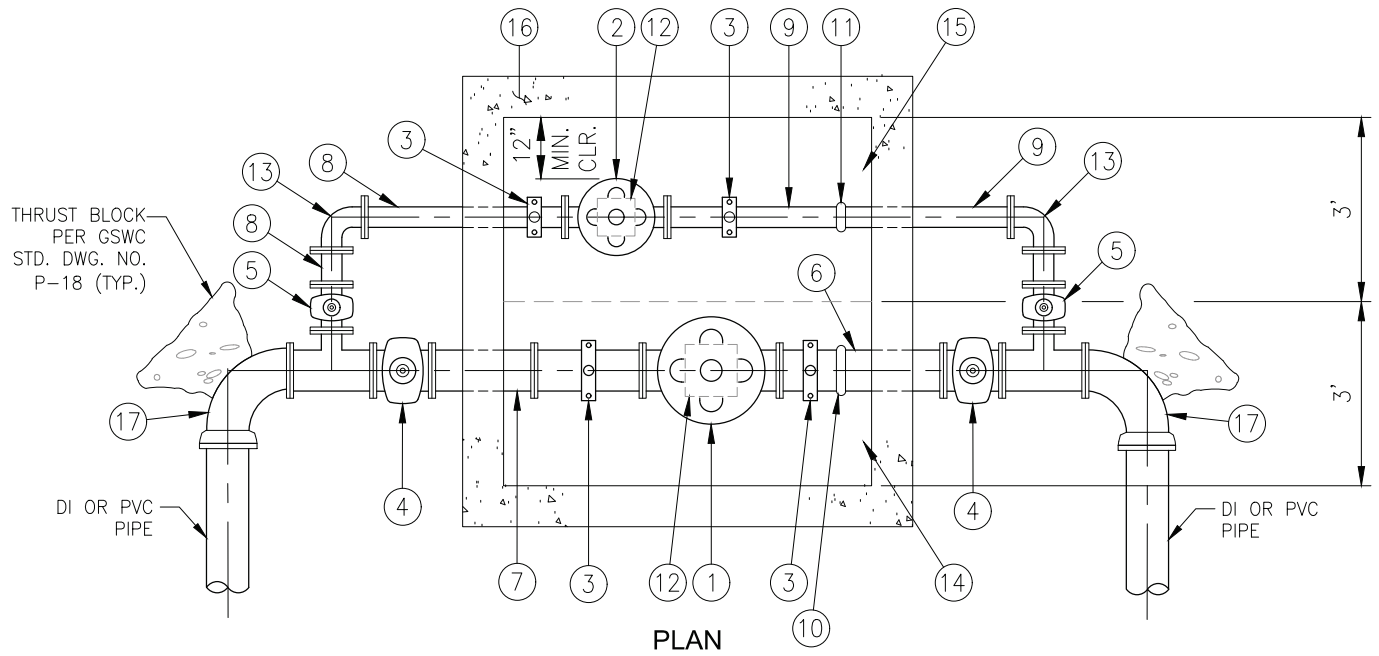

PLAN

SELECTION TABLE				
VALVE SIZE (INCHES)	MIN. FLOW RATE (GPM)	MAX. FLOW RATE (GPM)	DIA. BONNETT (INCHES)	REQUIRED CLEAR SPACE (INCHES)
1	1	55	5.6	18
1½	1	125	5.6	18
2	1	210	6.6	18
2½	2	300	8.0	20
3	2	460	9.1	22
4	4	800	11.5	24
6	10	1,800	15.8	40
8	15	3,100	20.0	44
10	35	4,900	23.6	48
12	50	7,000	28.0	52
14	70	8,400	32.8	*58
16	95	11,000	35.5	*60

* Pressure reducer valves larger than 12" may require a larger vault. Verify dimensions needed.

ITEM	DESCRIPTION
①	(D1) Pressure reducer valve, FE
②	(D2) Pressure reducer valve, FE
③	Service saddle with 1" ball valve for pressure gauges (4 req'd)
④	(D1) Gate valve, resilient wedge type (2 required)
⑤	(D2) Gate valve, resilient wedge type (2 required)
⑥	(D1) FE x grooved D.I. spool (length as required)
⑦	(D1) D.I. spool, FE
⑧	D.I. spool, FE (length as required)
⑨	D.I. spool, FExPE (length as required)
⑩	(D1) Victaulic coupling, grooved
⑪	(D2) Victaulic coupling, grooved
⑫	Pipe support (2 required)
⑬	90° elbow (2 required)
⑭	Required clear space for D1 valve
⑮	Required clear space for D2 valve
⑯	6'x6' concrete vault (shown) with H-20 rated spring assisted hinged lid (See GSWC Std. Dwg. No. P-36). Vault size to be determined based on valve size.
⑰	90° DI bend FE X MJ

NOTES:

- Contractor shall clearly and permanently label the pressure zones on the inlet and outlet pipes, using 2" min. high numerals and letters.
- Materials shall be selected from the Approved Materials List.
- Finished surface (FS) elevations shall be shown on the plans.
- Piping shall be painted "Desert Sand" for potable water.
- (D1) = Large Diameter. (D2) = Small Diameter.
- All pipes on both sides of vault shall be fully restrained.

APPROVED BY:
GSWC STANDARDS COMMITTEE

Alison Sweet

EDC MANAGER

6/15/26
DATE



Golden State
Water Company

A Subsidiary of American States Water Company

TITLE:

PRESSURE REGULATING STATION
(WITH LOW FLOW PRESSURE CONTROL
VALVE LARGER THAN 3-INCHES)

SCALE:
NONE

DATE:
02/23/26

REV
2026

STANDARD DWG NO.
P-34A

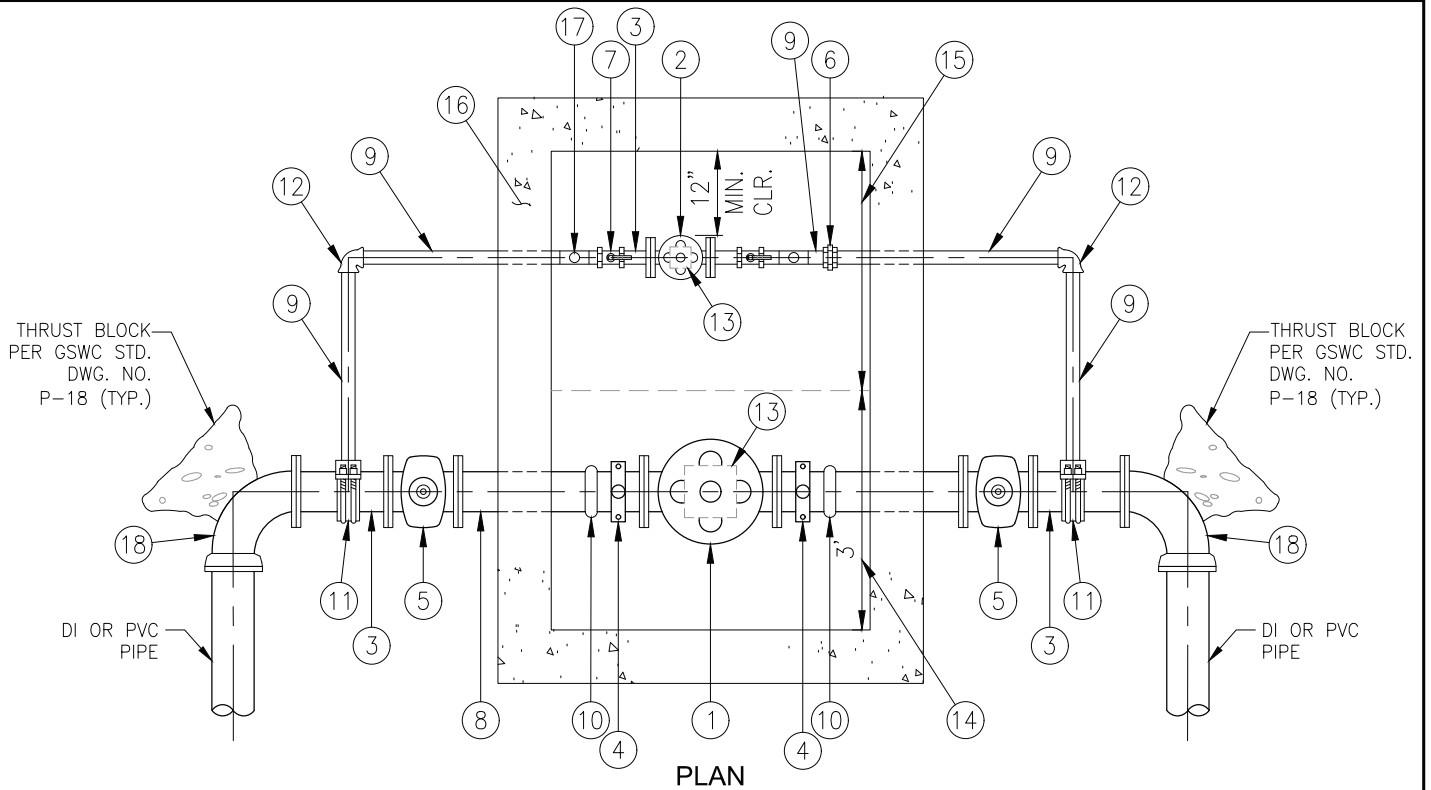

PLAN

SELECTION TABLE				
VALVE SIZE (INCHES)	MIN. FLOW RATE (GPM)	MAX. FLOW RATE (GPM)	DIA. BONNETT (INCHES)	REQUIRED CLEAR SPACE (INCHES)
2	1	210	6.6	18
2½	2	300	8.0	20
3	2	460	9.1	22
4	4	800	11.5	24
6	10	1,800	15.8	40
8	15	3,100	20.0	44
10	35	4,900	23.6	48
12	50	7,000	28.0	52
14	70	8,400	32.8	58
16	95	11,000	35.5	60

* Pressure reducer valves larger than 12" may require a larger vault. Verify dimensions needed.

ITEM	DESCRIPTION
①	(D1) Pressure reducer valve, FE
②	(D2) Pressure reducer valve, FE
③	FE x FE spool (length as required)
④	Service saddle with 1" ball valve for pressure gauges (2 req'd)
⑤	Gate valve resilient wedge type
⑥	Threaded copper union
⑦	Bronze ball valve (2 required)
⑧	FE x PE spool (length as required)
⑨	Copper pipe (Type K) with threaded ends
⑩	Victaulic coupling, grooved (2 required)
⑪	Service saddle, threaded
⑫	90° copper elbow
⑬	Pipe support (2 required)
⑭	Required clear space for D1 valve
⑮	Required clear space for D2 valve
⑯	4'x6'-6" concrete vault with H-20 rated spring assisted hinged lid (See GSWC Std. Dwg. No. P-36)
⑰	Copper tee with 1" ball valve for pressure gauges (2 req'd)
⑱	90° DI bend FE X MJ

NOTES:

- Contractor shall clearly and permanently label the pressure zones on the inlet and outlet pipes. Use 2" min. high numerals and letters.
- Materials shall be selected from the Approved Materials List.
- Finished surface (FS) elevations shall be shown on the plans.
- Piping shall be painted "Desert Sand" for potable water.
- (D1) = Large Diameter. (D2) = Small Diameter.
- All pipes on both sides of vault shall be fully restrained.

APPROVED BY:
GSWC STANDARDS COMMITTEE

Alison Sweet

EDC MANAGER

6/15/26
DATE



Golden State
Water Company

A Subsidiary of American States Water Company

TITLE:

**PRESSURE REGULATING STATION
(WITH LOW FLOW PRESSURE CONTROL
VALVE 2-INCH OR SMALLER)**

SCALE:	DATE:	REV	STANDARD DWG NO.
NONE	02/23/26	2026	P-34B

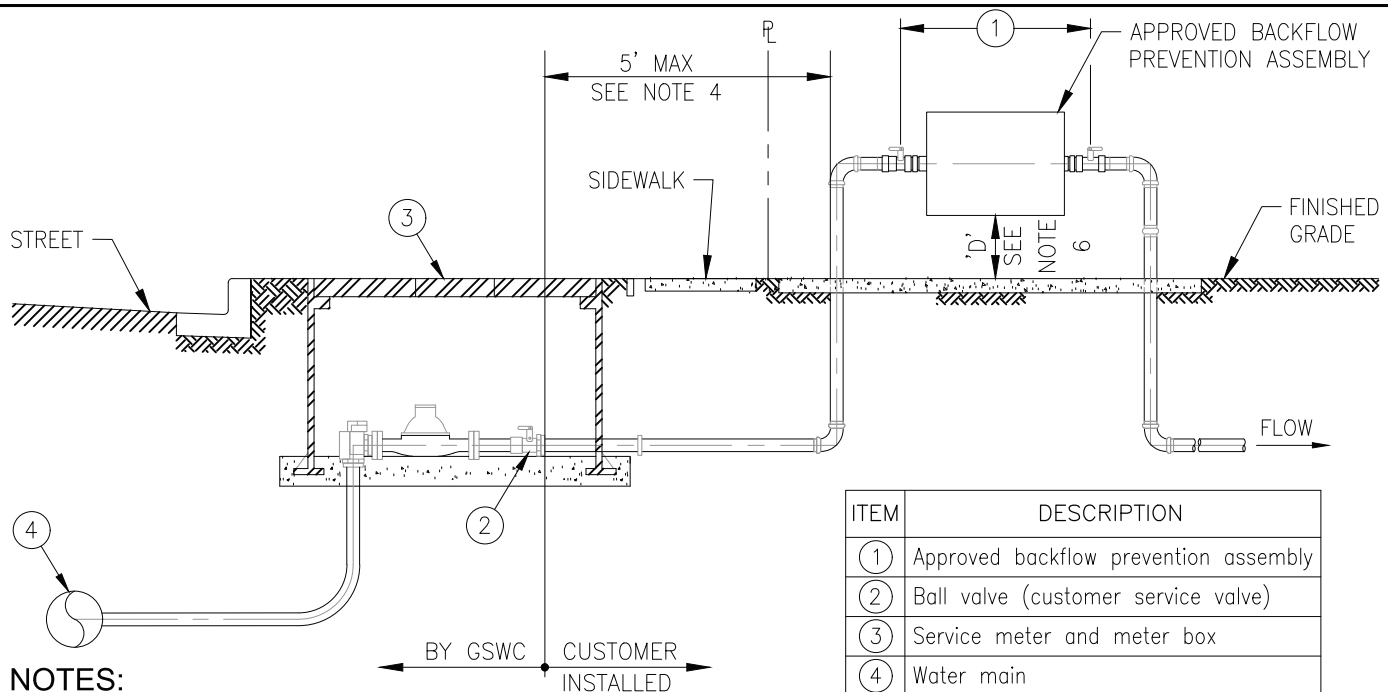

ITEM	DESCRIPTION
①	Approved backflow prevention assembly
②	Ball valve (customer service valve)
③	Service meter and meter box
④	Water main

NOTES:

- The customer is responsible for providing, installing, testing and maintaining all required backflow prevention equipment downstream of the meter.
- The backflow prevention assembly (BPA) installed shall appear and be noted as being lead-free in USC's List of Approved Backflow Prevention Assemblies.
- The required assembly type (DC, or RP) shall be determined by GSWC based on the degree of cross-connection hazard identified.
- The BPA must be installed within 5 feet of customer service valve. An installation beyond this distance requires prior written approval from GSWC.
- The BPA must have a minimum side clearance of 12" except that a minimum side clearance of 24" must be provided on the side of the assembly that contains the test cocks.
- The BPA must be installed such that the lowest point of an assembly (D) is a minimum of twelve inches above grade, and a maximum of thirty-six inches above the finished grade, unless an alternative is approved by GSWC.
- There shall be no tee fittings on piping connecting the meter and the BPA.
- The BPA shall not be installed in an area subject to flooding.
- The BPA shall be installed in the orientation approved by the backflow certifying agency(ies) (i.e. USC FCCCHR, ASSE).
- The BPA is to be used within its rated operating conditions.
- Only security enclosures providing adequate clearances and full view of assemblies are permitted. Landscape or construction around assembly shall permit an unobstructed view of the assembly from the street.
- Following installation, the BPA shall be tested by a certified tester in accordance with requirements set forth by the Division of Drinking Water and a test report submitted to backflowtest@gswater.com.
- Ongoing backflow testing shall be performed annually or as otherwise required by GSWC.
- It is recommended that the BPA be, at minimum, the same size as the supply pipe.
- It is recommended that BPAs sizes 3 inches and larger incorporate pipe support.
- Where static supply pressure exceeds 80 psi, pressure regulation shall be provided in accordance with section 608.2 of the Uniform Plumbing Code. Where a pressure-reducing valve (PRV) is used it shall be installed on the upstream side of the BPA.
- Where a wye strainer is used it shall be installed on the upstream side of the BPA.
- All installations of backflow assemblies must comply with state and local plumbing and building codes. Contact local administrative authority for detailed requirements.
- GSWC reserves the right to inspect all installations and require correction of any non-compliant condition.

APPROVED BY:
GSWC STANDARDS COMMITTEE

Alison Sweet
EDC MANAGER

6/15/26
DATE



TITLE:
BACKFLOW PREVENTION ASSEMBLY
FOR ABOVE GROUND INSTALLATION
(SERVICES 2" OR SMALLER)

SCALE: NONE	DATE: 11/14/25	REV: 2026	STANDARD DWG NO. P-35A
----------------	-------------------	--------------	---------------------------

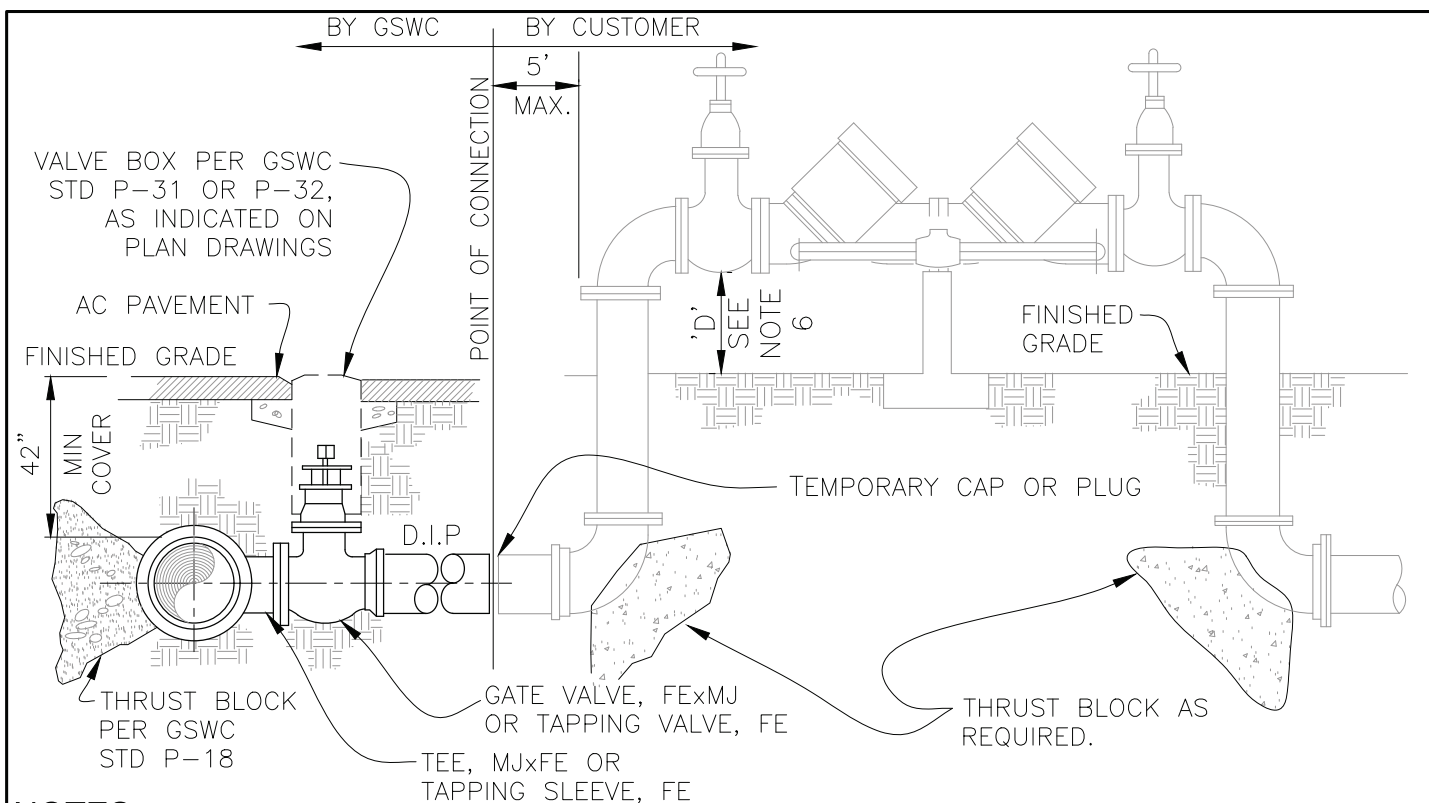

NOTES:

1. The customer is responsible for providing, installing, testing and maintaining all required backflow prevention equipment downstream of the meter/point of connection.
2. The backflow prevention assembly (BPA) installed shall appear and be noted as being lead-free in USC's List of Approved Backflow Prevention Assemblies.
3. The required assembly type (DCDA, RPDA, DC, or RP) shall be determined by GSWC based on the degree of cross-connection hazard identified and system configuration. Where a detector assembly is required, a Type-II assembly may be used.
4. The BPA must be installed within 5 feet of the point of connection. An installation beyond this distance requires prior written approval from GSWC.
5. The BPA must have a minimum side clearance of 12" except that a minimum side clearance of 24" must be provided on the side of the assembly that contains the test cocks.
6. The BPA must be installed such that the lowest point of an assembly (D) is a minimum of twelve inches above grade, and a maximum of thirty-six inches above the finished grade, unless an alternative is approved by GSWC.
7. There shall be no tee fittings on piping connecting the meter (or point of connection) and the BPA.
8. The BPA shall not be installed in an area subject to flooding.
9. The BPA shall be installed in the orientation approved by the backflow certifying agency(ies) (i.e. USC FCCCHR, ASSE).
10. The BPA is to be used within its rated operating conditions.
11. Only security enclosures providing adequate clearances and full view of the BPA are permitted. Landscape or construction around assembly shall permit an unobstructed view of the BPA from the street.
12. Following installation, the BPA shall be tested by a certified tester in accordance with requirements set forth by the Division of Drinking Water and a test report submitted to backflowtest@gswater.com.
13. Ongoing backflow testing shall be performed annually or as otherwise required by GSWC.
14. It is recommended that the BPA be, at minimum, the same size as the supply pipe.
15. It is recommended that BPAs sizes 3 inches and larger incorporate pipe support.
16. Where static supply pressure exceeds 80 psi, pressure regulation shall be provided in accordance with section 608.2 of the Uniform Plumbing Code. Where a pressure-reducing valve (PRV) is used it shall be installed on the upstream side of the BPA.
17. Where a wye strainer is used it must be installed on the upstream side of the BPA.
18. All installations of backflow assemblies must comply with state and local plumbing and building codes. Contact local administrative authority for detailed requirements.
19. GSWC reserves the right to inspect all installations and require correction of any non-compliant condition.

APPROVED BY:
GSWC STANDARDS COMMITTEE

Alison Sweet

EDC MANAGER

6/15/26
DATE



Golden State
Water Company

A Subsidiary of American States Water Company

TITLE:

**BACKFLOW PREVENTION ASSEMBLY
FOR ABOVE GROUND INSTALLATION
(SERVICES 4" OR LARGER)**

SCALE:	DATE:	REV	STANDARD DWG NO.
NONE	11/19/25	2026	P-35B

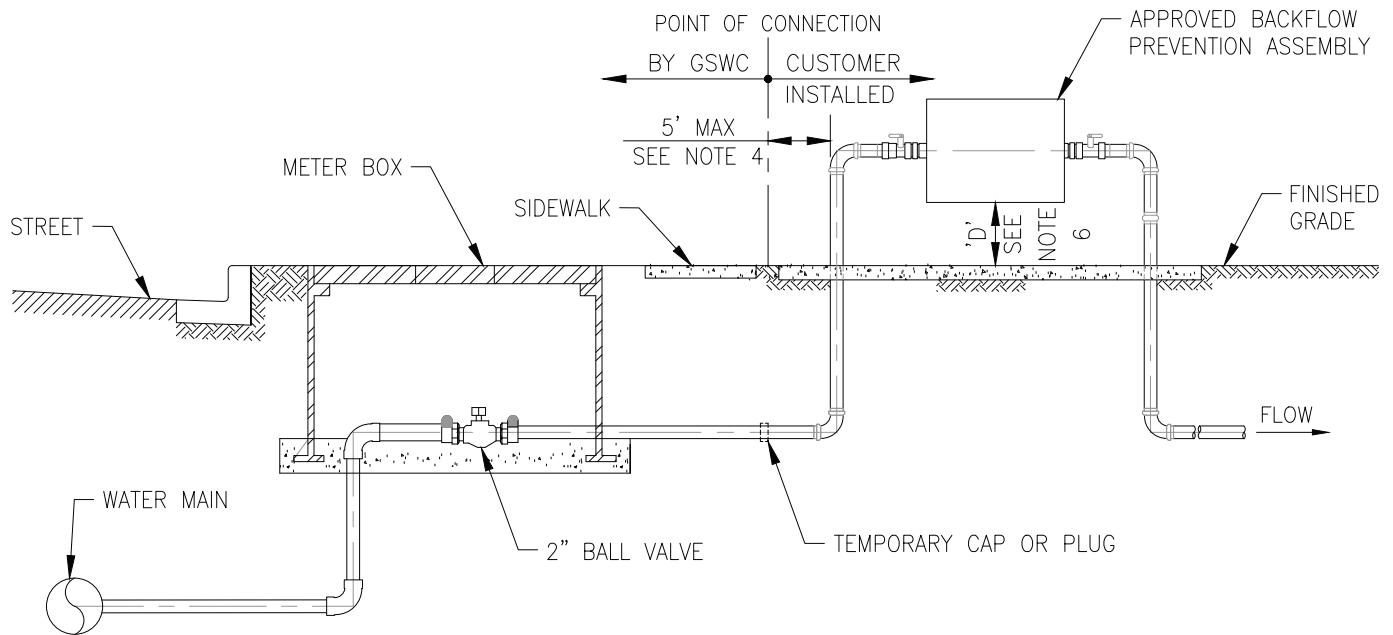

NOTES:

1. The customer is responsible for providing, installing, testing and maintaining all required backflow prevention equipment downstream of the meter/point of connection.
2. The backflow prevention assembly (BPA) installed shall appear and be noted as being lead-free in USC's List of Approved Backflow Prevention Assemblies.
3. The required assembly type (DCDA, RPDA, DC, or RP) shall be determined by GSWC based on the degree of cross-connection hazard identified and system configuration. Where a detector assembly is required, a Type-II assembly may be used.
4. The BPA must be installed within 5 feet of the point of connection. An installation beyond this distance requires prior written approval from GSWC.
5. The BPA must have a minimum side clearance of 12" except that a minimum side clearance of 24" must be provided on the side of the assembly that contains the test cocks.
6. The BPA must be installed such that the lowest point of an assembly (D) is a minimum of twelve inches above grade, and a maximum of thirty-six inches above the finished grade, unless an alternative is approved by GSWC.
7. There shall be no tee fittings on piping connecting the meter (or point of connection) and the BPA.
8. The BPA shall not be installed in an area subject to flooding.
9. The BPA shall be installed in the orientation approved by the backflow certifying agency(ies) (i.e. USC FCCCHR, ASSE).
10. The BPA is to be used within its rated operating conditions.
11. Only security enclosures providing adequate clearances and full view of the BPA are permitted. Landscape or construction around assembly shall permit an unobstructed view of the BPA from the street.
12. Following installation, the BPA shall be tested by a certified tester in accordance with requirements set forth by the Division of Drinking Water and a test report submitted to backflowtest@gswater.com.
13. Ongoing backflow testing shall be performed annually or as otherwise required by GSWC.
14. It is recommended that the BPA be, at minimum, the same size as the supply pipe.
15. It is recommended that BPAs sizes 3 inches and larger incorporate pipe support.
16. Where static supply pressure exceeds 80 psi, pressure regulation shall be provided in accordance with section 608.2 of the Uniform Plumbing Code. Where a pressure-reducing valve (PRV) is used it shall be installed on the upstream side of the BPA.
17. Where a wye strainer is used it must be installed on the upstream side of the BPA.
18. All installations of backflow assemblies must comply with state and local plumbing and building codes. Contact local administrative authority for detailed requirements.
19. GSWC reserves the right to inspect all installations and require correction of any non-compliant condition.

APPROVED BY:
GSWC STANDARDS COMMITTEE

Alison Sweet

EDC MANAGER

6/15/26
DATE



Golden State
Water Company

A Subsidiary of American States Water Company

TITLE:

**BACKFLOW PREVENTION ASSEMBLY
FOR 2" FIRE SERVICE INSTALLATION**

SCALE:
NONE

DATE:
11/19/25

REV
2026

STANDARD DWG NO.
P-35C

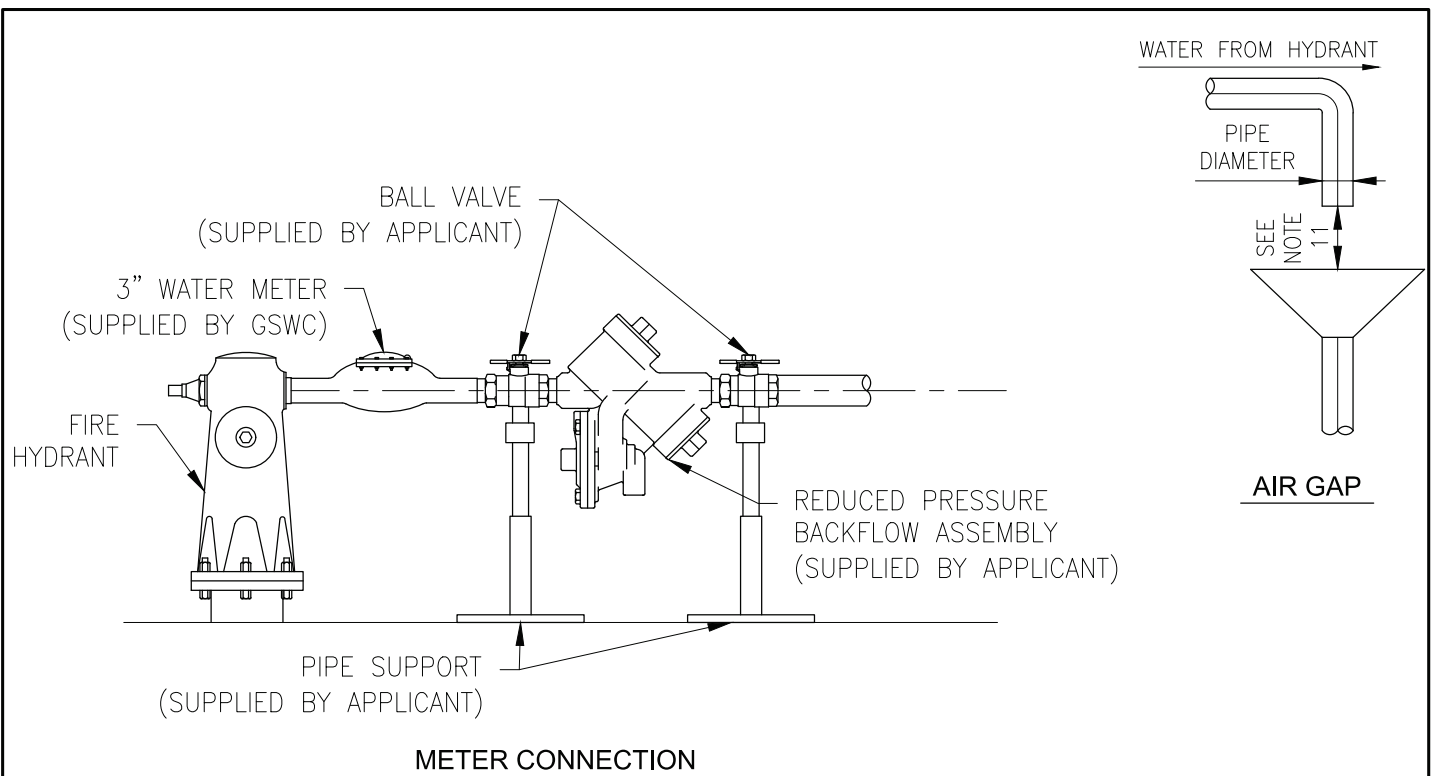

NOTES:

1. All hydrant meter installations shall include approved backflow prevention.
2. The customer is responsible for providing, installing, testing and maintaining all required backflow prevention equipment downstream of the hydrant meter.
3. A reduced pressure principle (RP) backflow prevention assembly shall be installed downstream of the hydrant meter unless an approved air gap is authorized by GSWC.
4. All backflow prevention assemblies (BPAs) must be listed and noted as lead-free on the USC Foundation for Cross-Connection Control and Hydraulic Research List of Approved Backflow Prevention Assemblies.
5. The BPA shall be installed in accordance with this drawing and all applicable state of California requirements.
6. Following installation, the BPA shall be tested by a certified tester in accordance with requirements set forth by the Division of Drinking Water.
7. A test report will need to be submitted to backflowtest@gswater.com within five (5) days of the hydrant meter being released to customer.
8. Ongoing backflow testing shall be performed at minimum quarterly or as otherwise required by GSWC.
9. If an approved air gap is used in lieu of the backflow prevention assembly, photos of the air gap must be submitted to backflowtest@gswater.com within five (5) days of the hydrant meter being released to customer.
10. Failure to submit the required documentation within the allotted time frame will result in termination of water service.
11. Any air gap used shall be set up in accordance with California Plumbing Code requirements, providing a minimum vertical separation of at least two (2) times the effective diameter of the supply pipe, but no less than one (1) inch.
12. The air gap shall be maintained in a manner that preserves the required separation. The customer shall be responsible for ensuring the air gap is not altered, bypassed, or rendered ineffective.
13. The air gap shall be inspected at minimum annually or as otherwise required by GSWC.
14. The customer is the sole party responsible for safeguarding the hydrant meter & the BPA (where applicable) once hydrant meter has been released to customer.
15. GSWC reserves the right to inspect all installations and require correction of any non-compliant condition.

APPROVED BY: GSWC STANDARDS COMMITTEE  EDC MANAGER	 Golden State Water Company <small>A Subsidiary of American States Water Company</small>	TITLE: METERED FIRE HYDRANT WITH BACKFLOW PREVENTION ASSEMBLY SCALE: NONE DATE: 02/05/26 REV: 2026 STANDARD DWG NO. P-35D
--	--	--

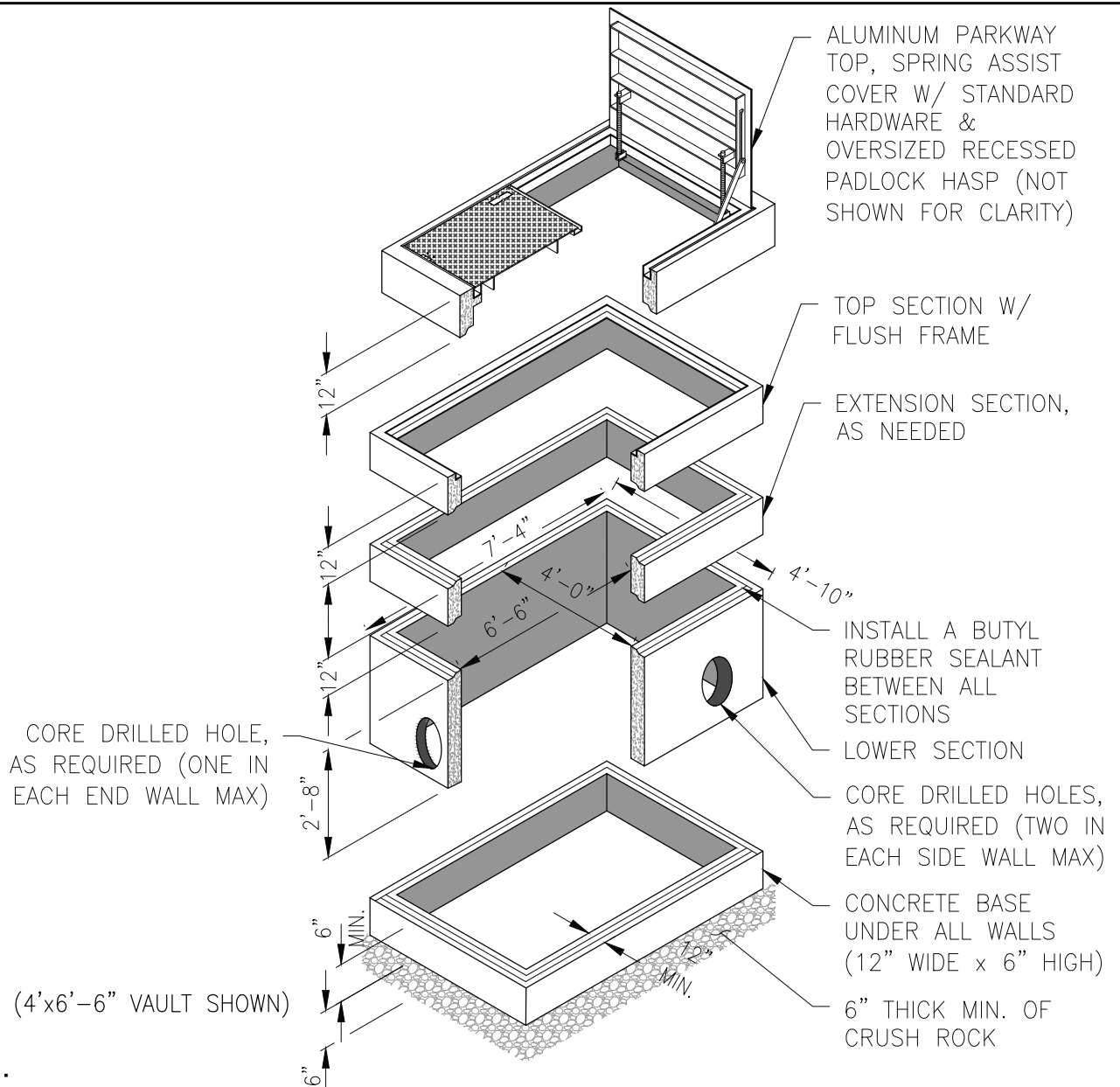

NOTES:

1. Vaults shall be designed for AASHTO 20K loads with open bottom and lockable torsion spring assisted aluminum lids.
2. When total depth is greater than 5 feet an attached aluminum ladder shall be provided with a Ladder-up Safety Pole.
3. Vaults for meter installation shall be equipped with a meter reading lid centered over the meter if called for on the plans.
4. Joints between vault sections shall have a butyl rubber sealant installed.
5. Install 6" high x12" wide concrete base under all vault walls.
6. Bottom of vault shall be filled with 8" thick minimum layer of compacted $\frac{3}{4}$ " crushed rock compacted or Class 2 AB.
7. Core wall for pipe spool. Core diameter shall be pipe O.D. +4" min. See Std. Dwg. No. P-37 for details.
8. 6" thick min. crushed rock under vault base extending 6" min. beyond vault base on all sides.

APPROVED BY:
 GSWC STANDARDS COMMITTEE

 EDC MANAGER

6/15/26
 DATE

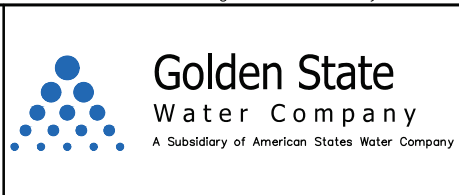

TITLE: UTILITY VAULT INSTALLATION			
SCALE: NONE	DATE: 07/31/23	REV: 2024	STANDARD DWG NO. P-36

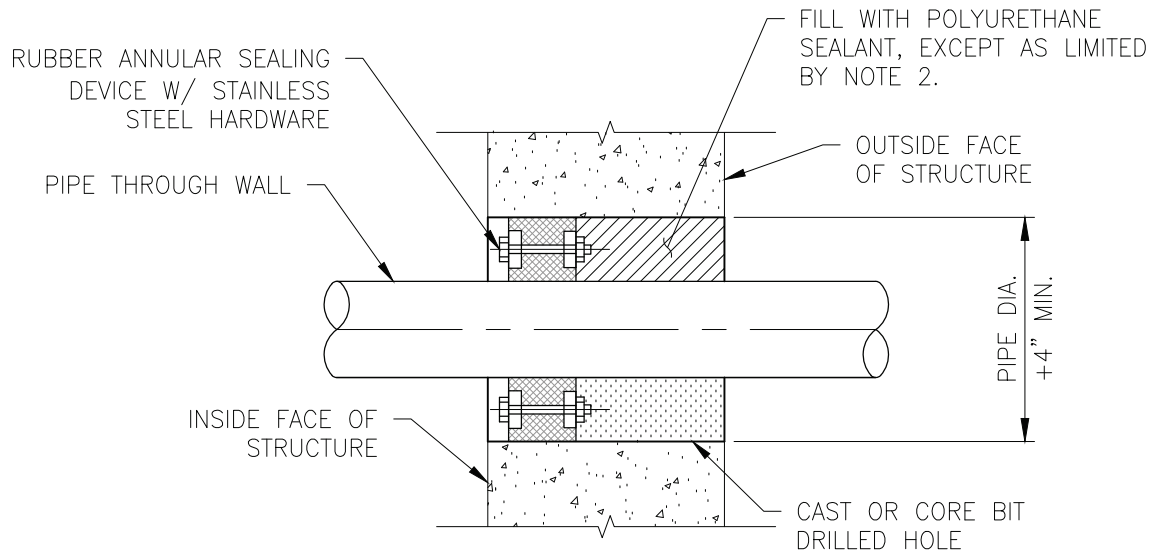

NOTES:

1. Opening thru vault wall shall be sized to accommodate pipe and rubber sealing device.
2. Buried application is shown. Where outside face of structure is above grade, fill the outside 2" of the sleeve with non-shrink grout.
3. See Approved Materials List for approved list of manufacturers.

APPROVED BY:
GSWC STANDARDS COMMITTEE

Alison Sweet

EDC MANAGER

6/15/26
DATE



Golden State
Water Company

A Subsidiary of American States Water Company

TITLE:

SEALING PIPE OPENING
THROUGH VAULT

SCALE:
NONE

DATE:
02/23/26

REV
2026

STANDARD DWG NO.
P-37

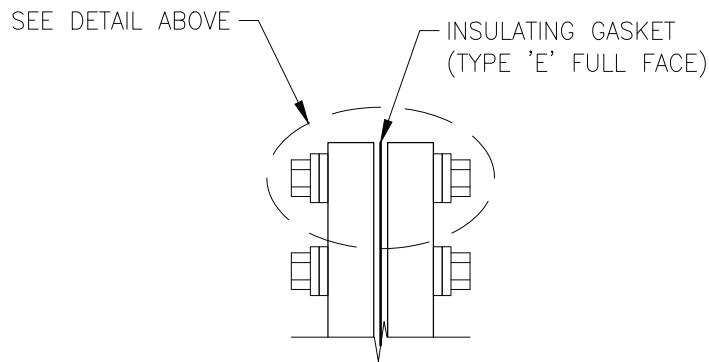
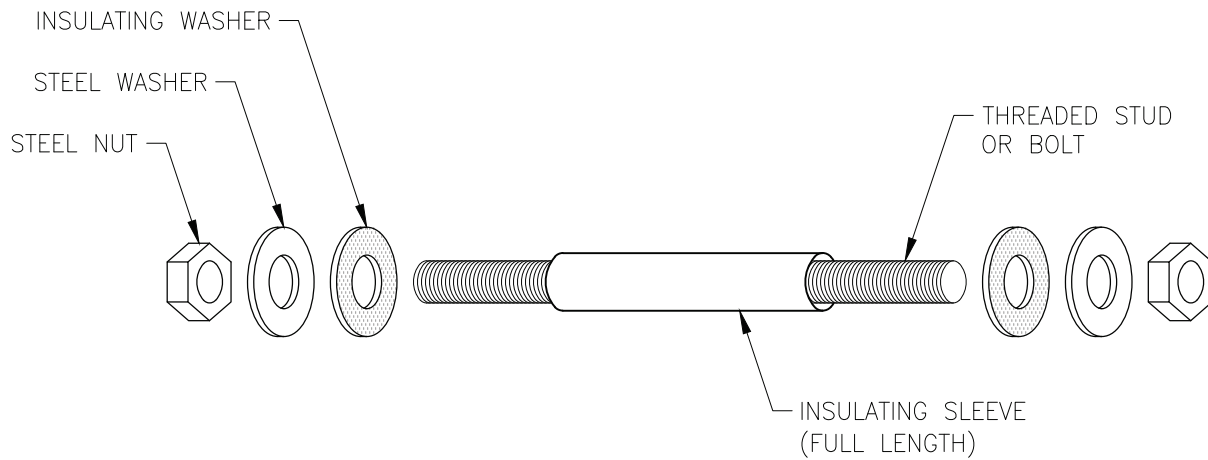

NOTES:

1. Gasket shall be Type 'E' full face phenolic with O-Ring.
2. Sleeve shall be G10 Class.
3. Washers shall be G10 Class.

APPROVED BY:
GSWC STANDARDS COMMITTEE

Alison Sweet

EDC MANAGER

6/15/26
DATE



Golden State
Water Company

A Subsidiary of American States Water Company

TITLE:

INSULATING FLANGE KIT
MATERIALS

SCALE:
NONE

DATE:
07/31/23

REV
2024

STANDARD DWG NO.
P-38

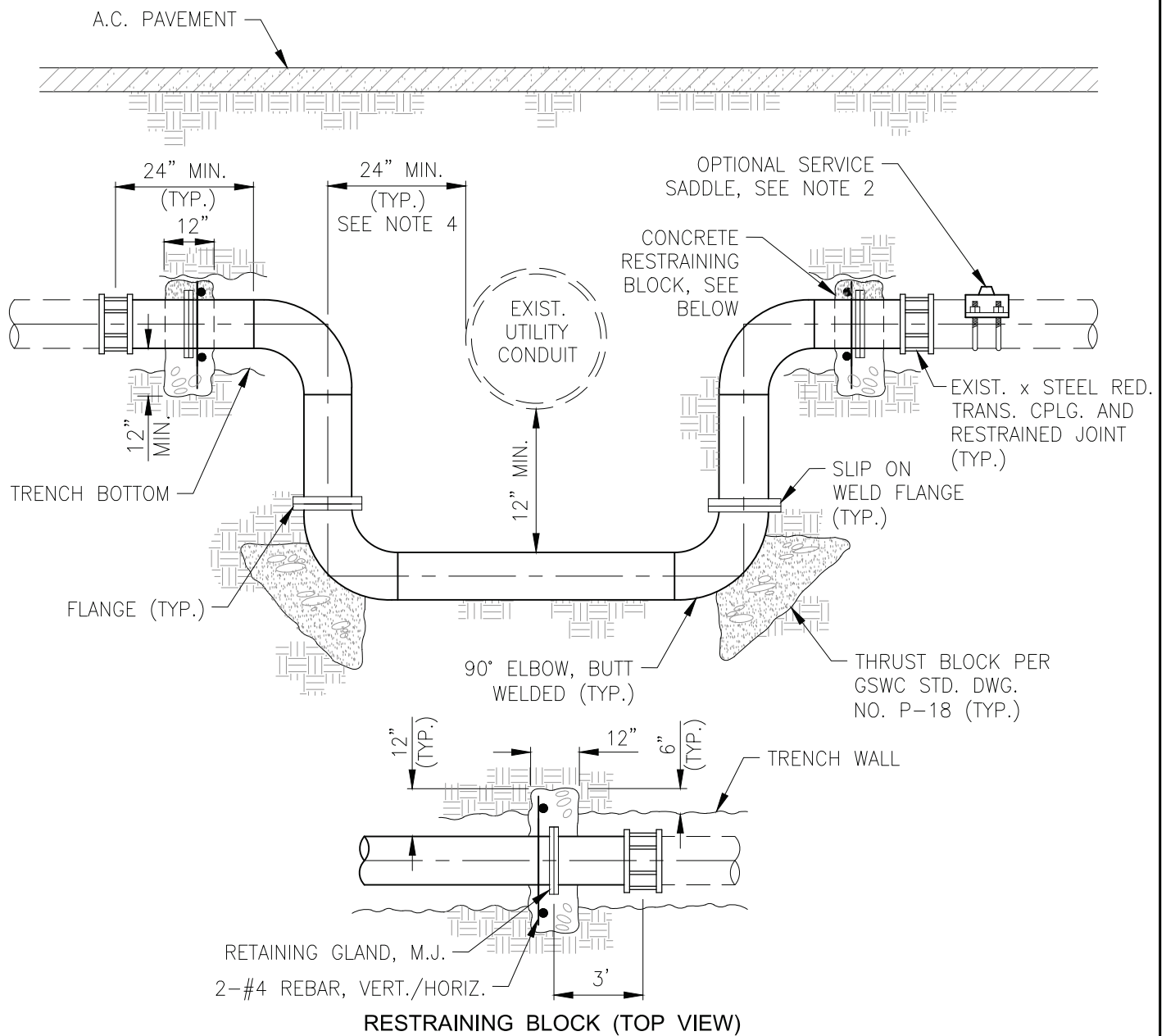

RESTRAINING BLOCK (TOP VIEW)

NOTES:

1. Pipe and fittings shall be standard weight steel, fusion bonded epoxy lined and coated per AWWA C550. All inverts shall be shop fabricated with exception of field installation of weld-on-flanges. Units shall provide 12" extra vertical length.
2. Service saddle shall be installed on the high points of the offset for the installation of combination air release vacuum relief valve, as shown on the plan. Service saddle shall be 1" on 8" and smaller mains, and 2" on larger existing mains.
3. If utility conduit is non-potable, minimum distance shall comply with DDW Waterworks Standards and Std. Dwg. No. P-2.
4. Trench backfill and bedding shall be as shown on Standard Drawing No. P-3 or as required by the local agency.
5. All rebar that is not encased within concrete is to be covered with 80 mils of bitumastic compound.

APPROVED BY:
GSWC STANDARDS COMMITTEE

Alison Sweet

EDC MANAGER

6/15/26
DATE



Golden State
Water Company

A Subsidiary of American States Water Company

TITLE:

**90-DEGREE WELDED STEEL
UTILITY INVERT**

SCALE:	DATE:	REV	STANDARD DWG NO.
NONE	11/19/25	2026	P-39

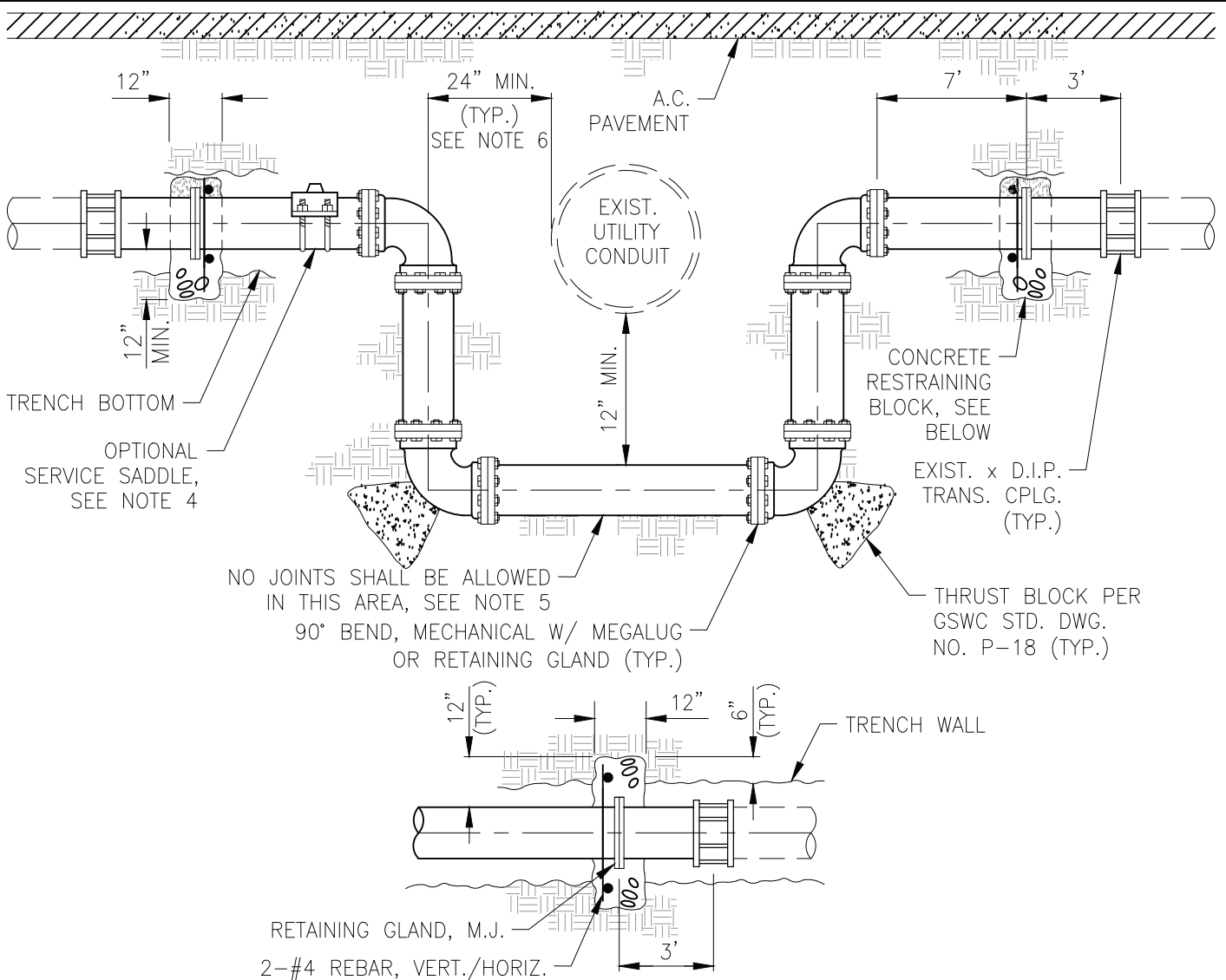

NO JOINTS SHALL BE ALLOWED IN THIS AREA, SEE NOTE 5
 90° BEND, MECHANICAL W/ MEGALUG OR RETAINING GLAND (TYP.)

RESTRAINING BLOCK (TOP VIEW)

NOTES:

1. The concrete restraining blocks shall be a minimum of 24" high and 12" thick. The top of the block shall be no more than 6" above top of pipe.
2. All pipe joints at 90° bends shall be mechanical joint with Megalug or retaining gland. Flanged joints may be used where conditions warrant.
3. Installation shall be encased in a polyethylene wrapper per AWWA Standard C105.
4. Service saddle and combination air release vacuum relief valve shall be installed on the high points of the offset as shown or the plans. Service saddle shall be 1" on 8" and smaller existing mains and 2" on larger existing mains.
5. If bottom spool piece exceeds 18 feet, connect pipe sections with GSWC approved joint restraints.
6. If utility conduit is non-potable, minimum dimension shall comply with DDW Waterworks Standards and Std. Dwg. No. P-2.
7. Trench backfill and bedding shall be as shown on Standard Drawing No. P-3 or as required by the local agency.
8. All rebar that is not encased within concrete is to be covered with 80 mils of bitumastic compound.

APPROVED BY:
 GSWC STANDARDS COMMITTEE

 EDC MANAGER
 6/15/26
 DATE



TITLE: 90-DEGREE MECHANICAL JOINT D.I.P. UTILITY INVERT			
SCALE: NONE	DATE: 11/19/25	REV: 2026	STANDARD DWG NO. P-40

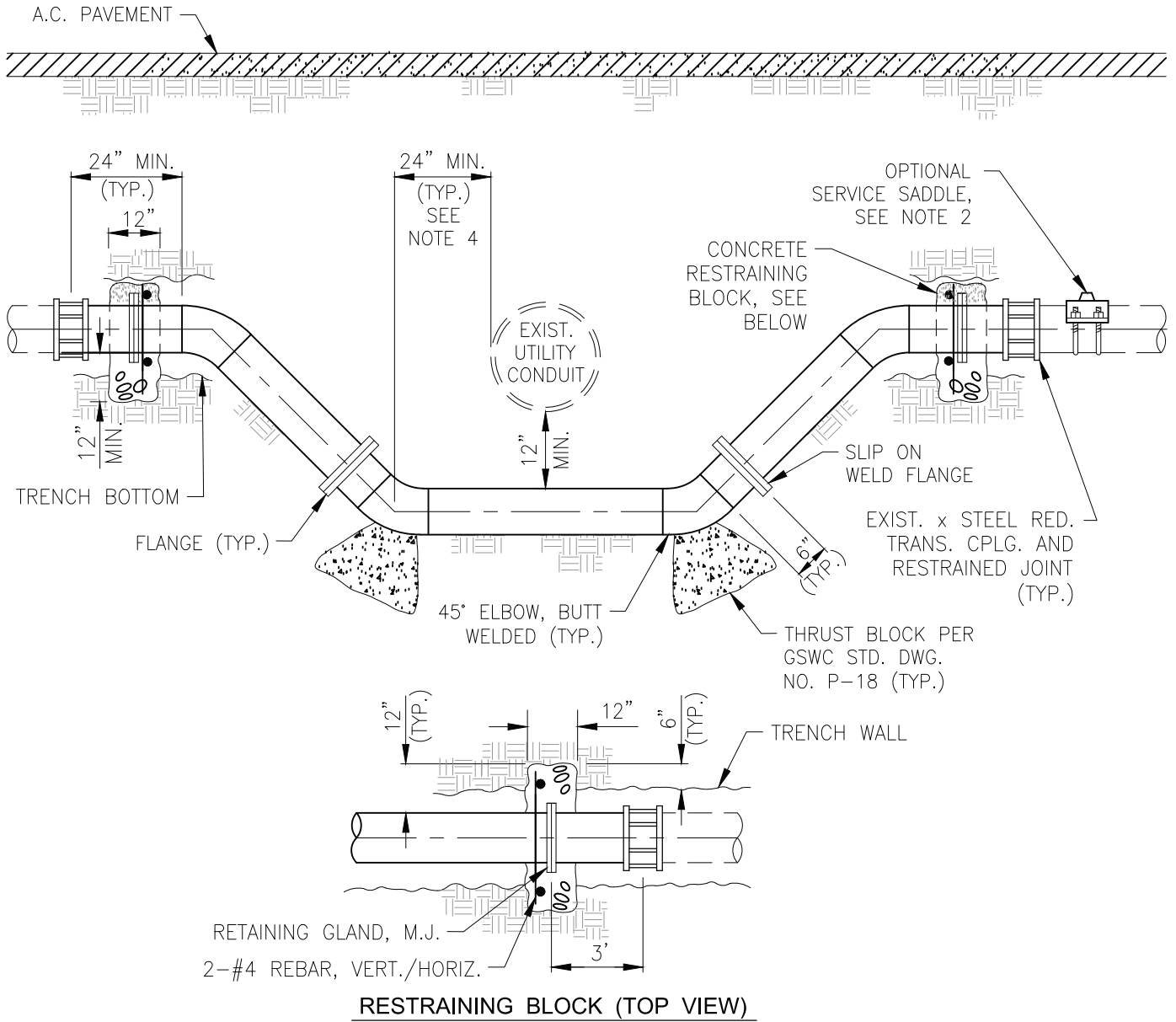

NOTES:

1. Pipe and fittings shall be standard weight steel, fusion bonded epoxy lined and coated per AWWA C550. All inverts shall be shop fabricated with exception of field installation of weld-on-flanges. Units shall provide 12" extra vertical length.
2. Service saddle shall be installed on the high points of the offset for the installation of combination air release vacuum relief valve, as shown on the plan. Service saddle shall be 1" on 8" and smaller mains and 2" on larger existing mains.
3. If utility conduit is non-potable, minimum distance shall comply with DDW Waterworks Standards and Std. Dwg. No. P-2.
4. Trench backfill and bedding shall be as shown on Std. Dwg. No. P-3 or as required by the local agency.
5. All rebar that is not encased within concrete is to be covered with 80 mils of bitumastic compound.

APPROVED BY:
GSWC STANDARDS COMMITTEE

Alison Sweet

EDC MANAGER

6/15/26
DATE



Golden State
Water Company

A Subsidiary of American States Water Company

TITLE:

**45-DEGREE WELDED STEEL
UTILITY INVERT**

SCALE:
NONE

DATE:
11/19/25

REV
2026

STANDARD DWG NO.
P-41

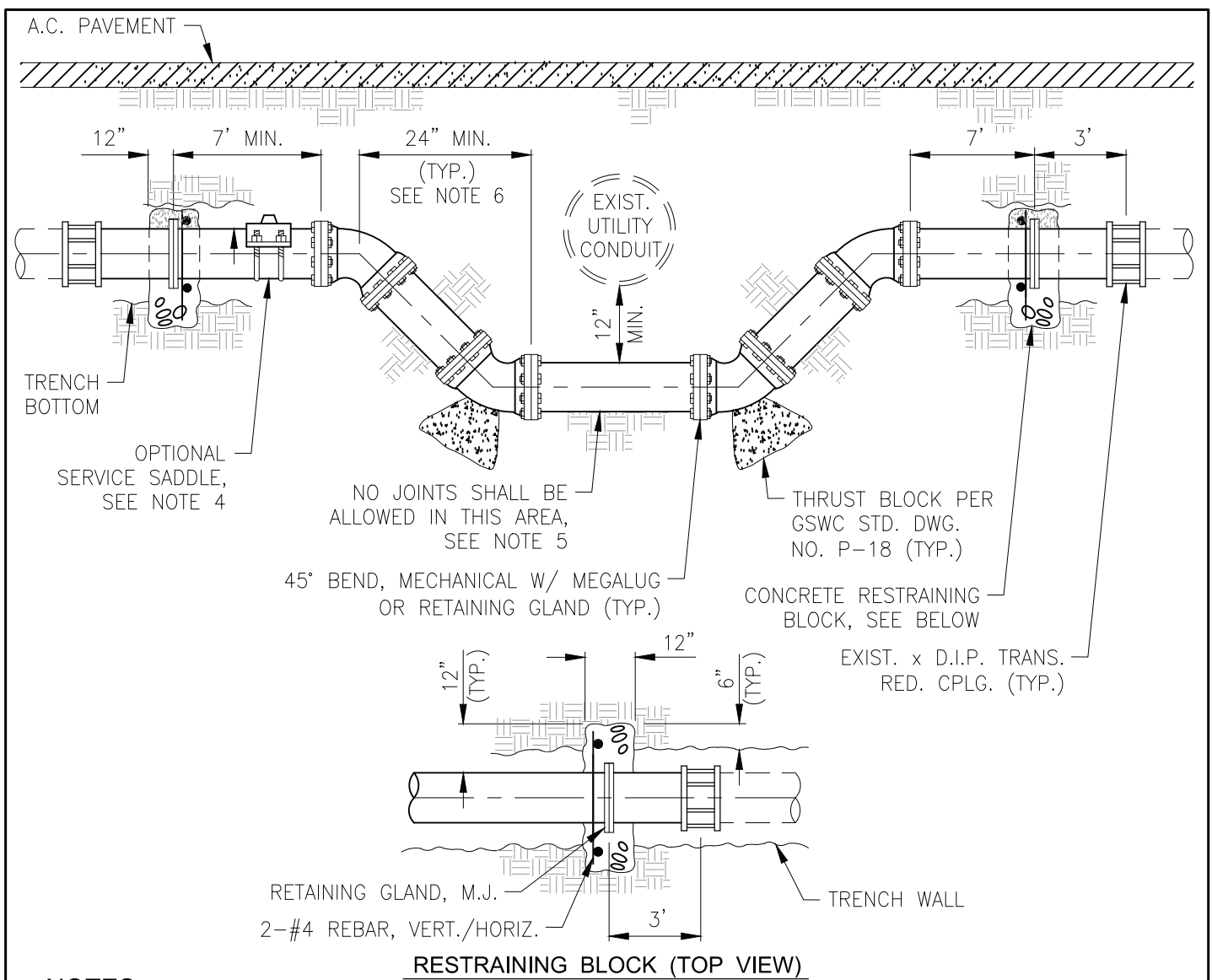

NOTES:

1. The concrete restraining blocks shall be a minimum of 24" high and 12" thick. The top of the block shall be no more than 6" above top of pipe.
2. All pipe joints at 90° bends shall be mechanical joint with Megalug or retaining gland. Flanged joints may be used where conditions warrant.
3. Installation shall be encased in a polyethylene wrapper per AWWA Standard C105.
4. Service saddle and combination air release vacuum relief valve shall be installed on the high points of the offset as shown on the plans. Service saddle shall be 1" on 8" and smaller existing mains and 2" on larger existing mains.
5. If bottom spool piece exceeds 18 feet, connect pipe sections with GSWC approved joint restraints.
6. If utility conduit is non-potable, minimum dimension shall comply with DDW Waterworks Standards and Std. Dwg. No. P-2.
7. Trench backfill and bedding shall be as shown on Std. Dwg. No. P-3 or as required by the local agency.
8. All rebar that is not encased within concrete is to be covered with 80 mils of bitumastic compound.

APPROVED BY:
GSWC STANDARDS COMMITTEE

Alison Sweet

EDC MANAGER

6/15/26
DATE



Golden State
Water Company

A Subsidiary of American States Water Company

TITLE:

**45-DEGREE MECHANICAL JOINT D.I.P.
UTILITY INVERT**

SCALE:
NONE

DATE:
11/19/25

REV
2026

STANDARD DWG NO.
P-42

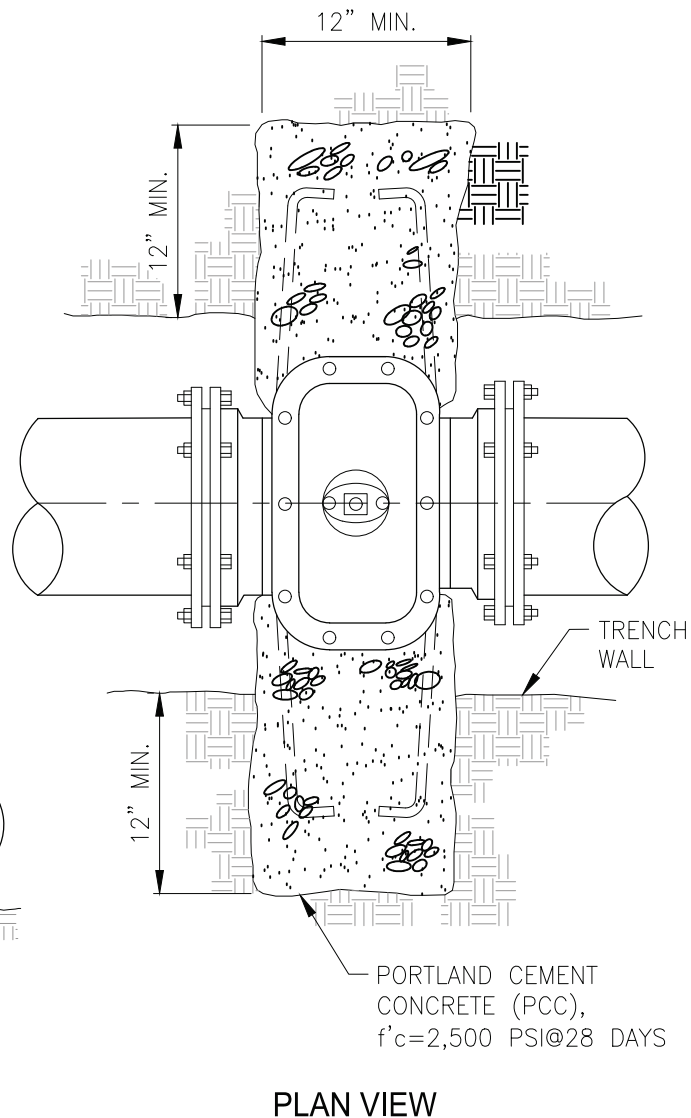
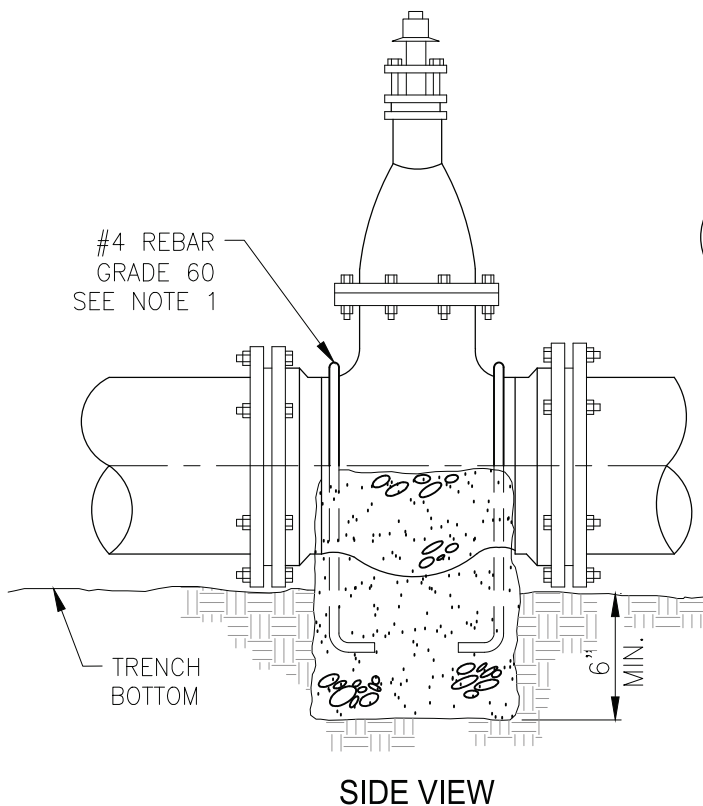
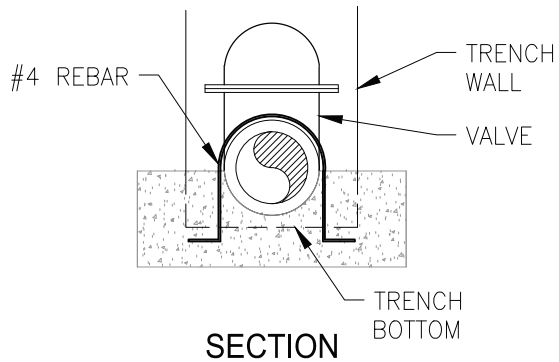

NOTES:

1. All rebar that is not encased within concrete is to be covered with 80 mils of bitumastic compound.
2. The anchor block shall be keyed no less than 12 inches into undisturbed soil of the trench wall and no less than 6 inches into the trench bottom.
3. Anchor block required only when valve is not flanged to a tee or cross.
4. Concrete shall be 2500 psi minimum with 3-inches minimum cover rebar. No concrete shall be poured on valve or joint.
5. Wrap exterior of valve, actuator and rebar with 8 mil polyethylene sheeting and tape.

APPROVED BY:
GSWC STANDARDS COMMITTEE

Alison Sweet

EDC MANAGER

6/15/26
DATE



Golden State
Water Company

A Subsidiary of American States Water Company

TITLE:

VALVE ANCHOR

SCALE:	DATE:	REV	STANDARD DWG NO.
NONE	11/19/25	2026	P-43

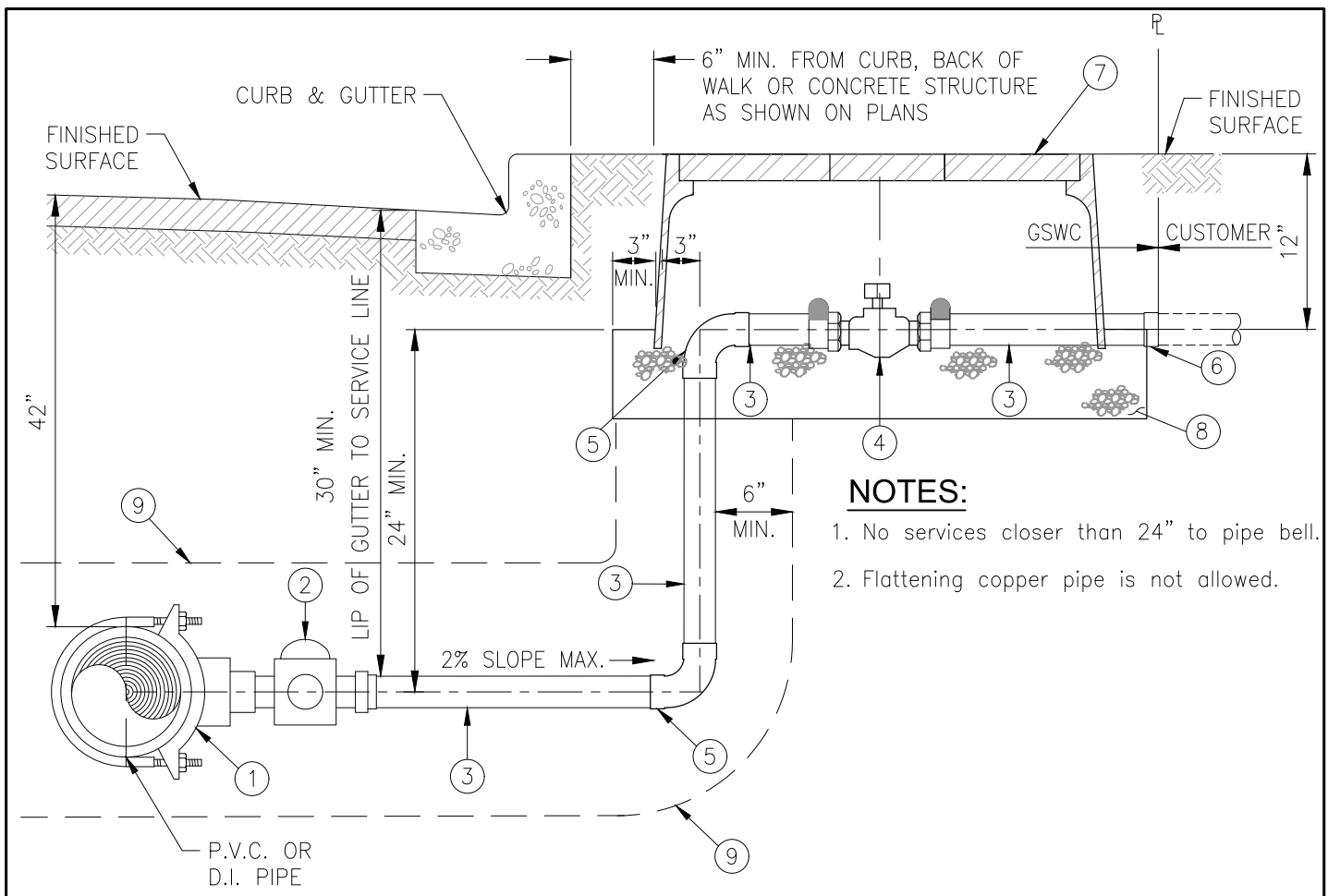

NOTES:

1. No services closer than 24" to pipe bell.
2. Flattening copper pipe is not allowed.

ITEM	EACH	DESCRIPTION	SPECIFICATION	REMARKS
①	1	Service saddle	Strap to be S.S. or bronze	See Approved Materials List
②	1	2" ball valve corp. stop	2" Solder x C.T.S. compression	See Approved Materials List
③	4	Copper tubing	2" Type K, soft	One piece only, no bends, unless elbow is used. Elbow joints to be silver soldered.
④	1	2" ball valve	2" curb stop w/square nut, C.T.S. compression x C.T.S. compression	See Approved Materials List
⑤	2	Elbow	2" Solder x Solder	See Approved Materials List
⑥	1	Temporary cap	2" copper cap, Solder	See Approved Materials List
⑦	1	Water meter box	17"x30" meter box	See Approved Materials List
⑧	1	Water meter box pad	20"x34"x6", 3/4" crushed rock	Pad for meter box
⑨	1	Trench with sand envelope	Imported with SE > 30	12" min. & 24" max. trench width

APPROVED BY:
GSWC STANDARDS COMMITTEE

Alison Sweet

EDC MANAGER

6/15/26
DATE



Golden State
Water Company

A Subsidiary of American States Water Company

TITLE:

**2-INCH WATER
FIRE SERVICE CONNECTION**

SCALE: NONE	DATE: 01/28/26	REV 2026	STANDARD DWG NO. P-44
----------------	-------------------	-------------	--------------------------

Section 2

Civil and Site Work

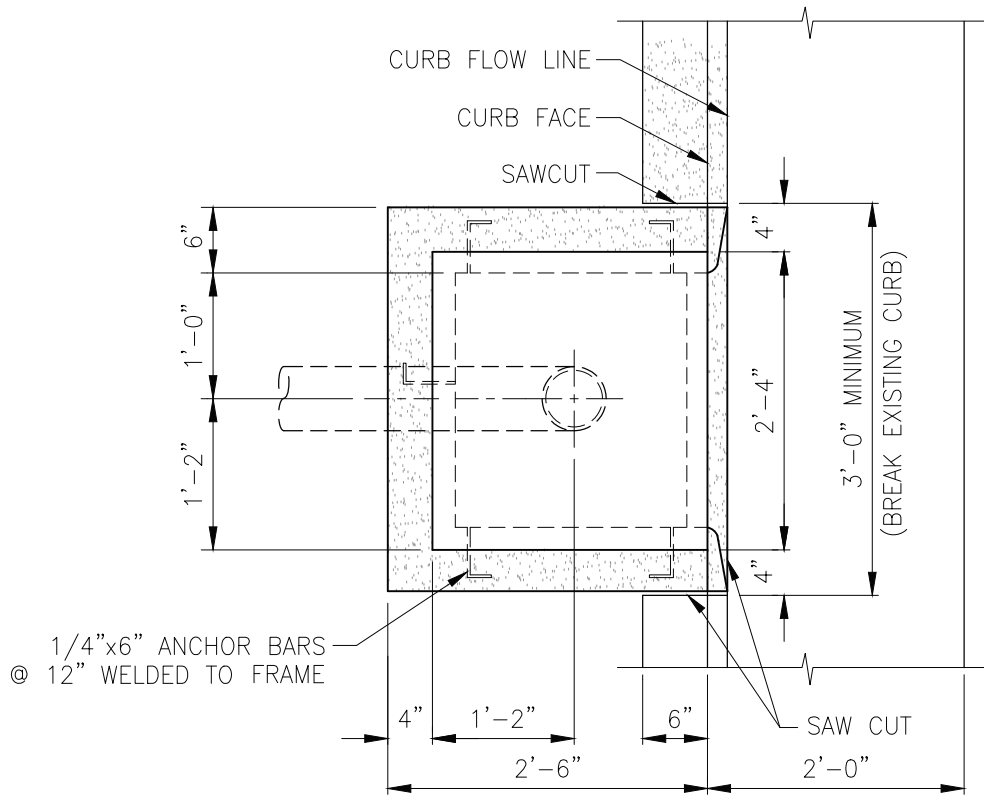

PLAN

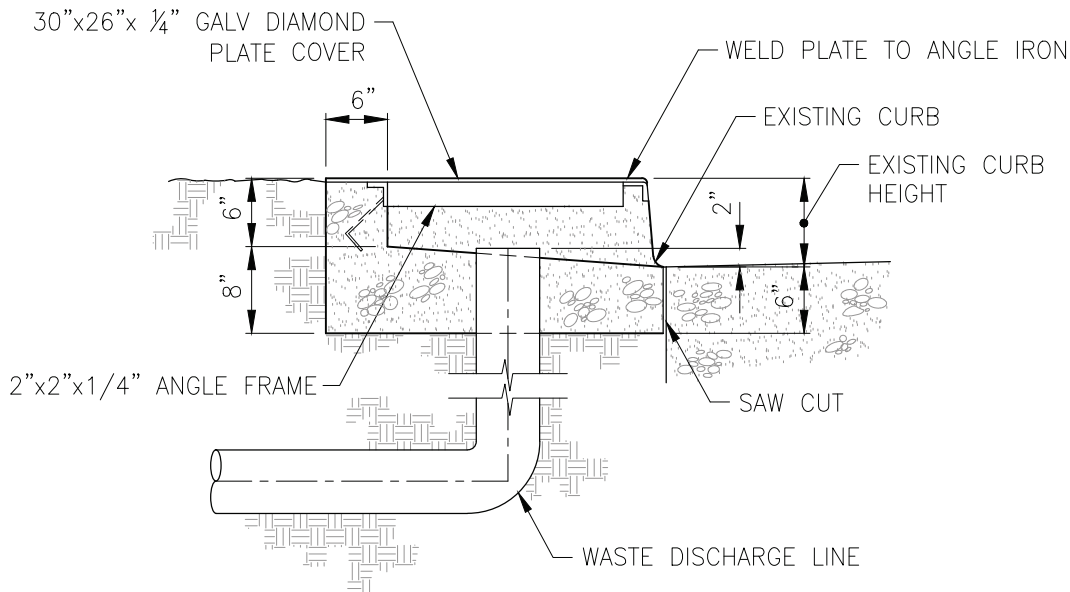

SECTION

NOTES:

1. This is to be used only where a storm drain connection cannot be made.
2. If existing curb is cracked or has an expansion joint within 3 feet of the proposed saw cut, extend limits of cut to that point.
3. An approved backflow prevention method shall be installed upstream to curb drain box.

APPROVED BY: GSWC STANDARDS COMMITTEE EDC MANAGER	 Golden State Water Company <small>A Subsidiary of American States Water Company</small>	TITLE: <p style="text-align: center; font-weight: bold;">CURB DRAIN BOX</p>		
6/15/26 DATE	SCALE: NONE	DATE: 07/31/23	REV 2024	STANDARD DWG NO. C-1

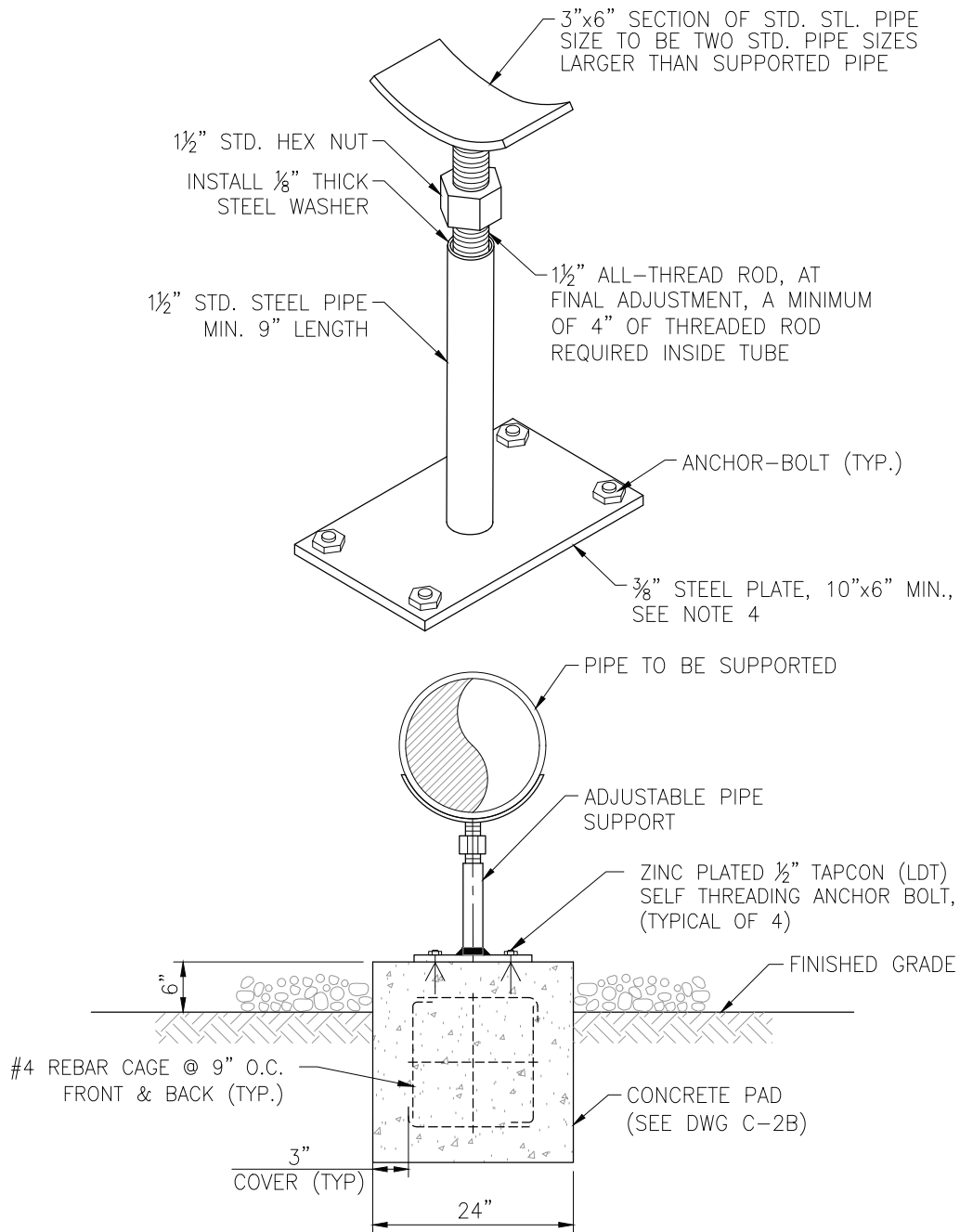

PIPE SUPPORT DETAIL (1/-)
N.T.S.

NOTES:

1. Pipe supports shall be painted and coated in accordance with the GSWC standard paint specifications. Color to match piping.
2. All threaded areas shall be coated with "never-seize" or other equivalent anti-rust lubricant.
3. Support to be installed under all valves and at 10 foot maximum spacing.
4. Steel plate can be attached to a concrete pad using wedge type anchor bolts designed for use in concrete. Anchor bolts shall be installed at least 2" into concrete and be 1/2" diameter x 3" long to allow for a washer and nut on the end. Bolt, washer and nut shall be galvanized for corrosion protection.

APPROVED BY:
GSWC STANDARDS COMMITTEE

Alison Sweet
EDC MANAGER

6/15/26
DATE



Golden State
Water Company
A Subsidiary of American States Water Company

TITLE:
ADJUSTABLE PIPE SUPPORT

SCALE: NONE	DATE: 11/20/25	REV 2026	STANDARD DWG NO. C-2A
----------------	-------------------	-------------	--------------------------

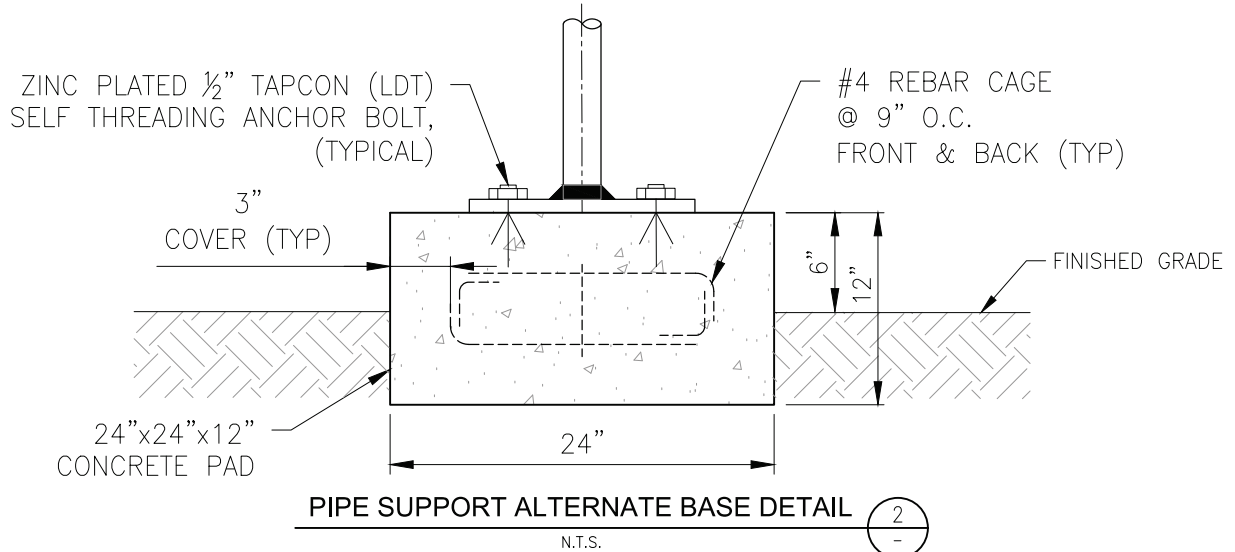
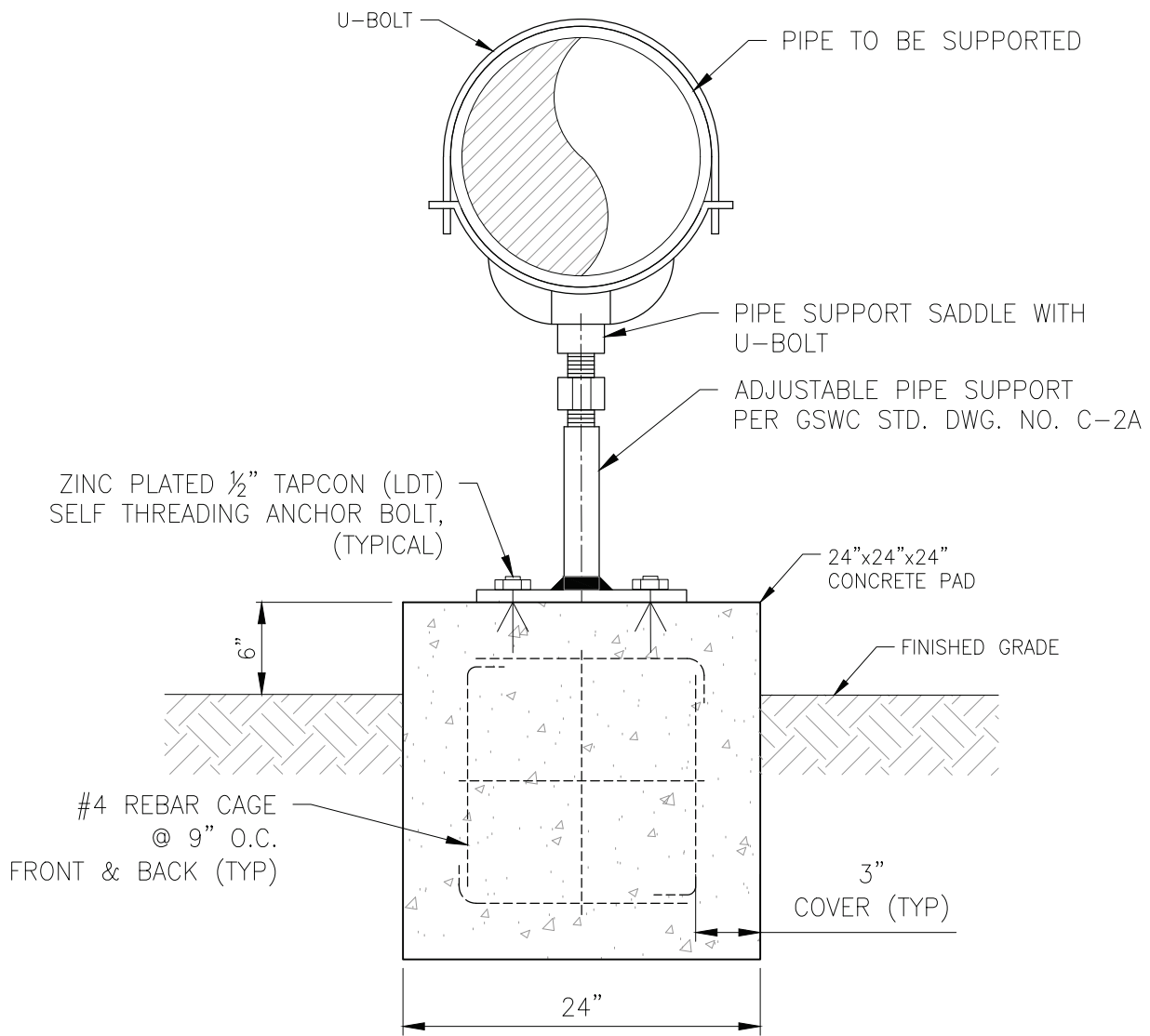

APPROVED BY:
GSWC STANDARDS COMMITTEE

Alison Sweet

EDC MANAGER

6/15/26
DATE



Golden State
Water Company

A Subsidiary of American States Water Company

TITLE:

ADJUSTABLE PIPE SUPPORT WITH
RESTRAINING U-BOLT AND ANCHORS

SCALE:
NONE

DATE:
11/20/25

REV
2026

STANDARD DWG NO.
C-2B

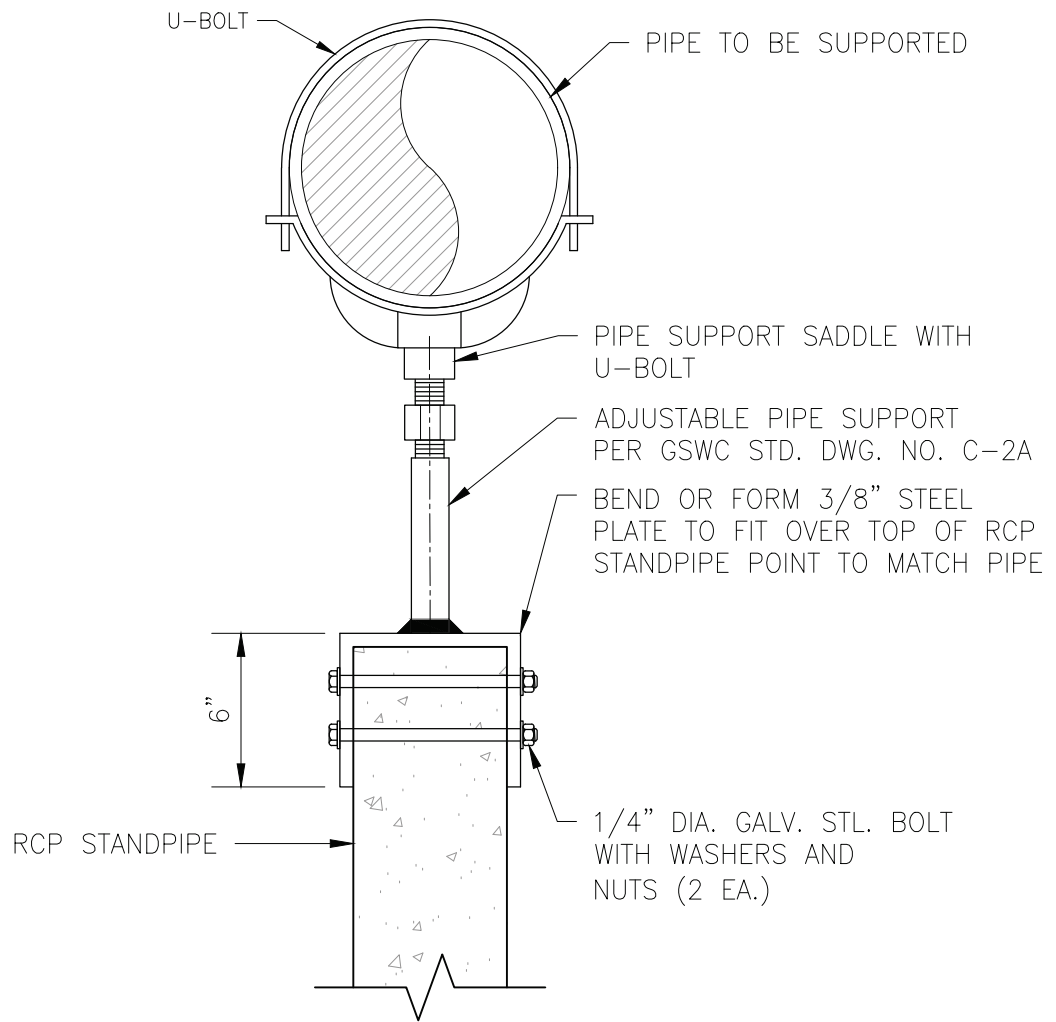

RCP STANDPIPE PIPE SUPPORT DETAIL

N.T.S.



APPROVED BY:
GSWC STANDARDS COMMITTEE

Alison Sweet

EDC MANAGER

6/15/26
DATE



Golden State
Water Company

A Subsidiary of American States Water Company

TITLE:

ADJUSTABLE PIPE SUPPORT WITH
RESTRAINING U-BOLT ON
RCP STANDPIPE

SCALE:
NONE

DATE:
11/20/25

REV
2026

STANDARD DWG NO.
C-2C

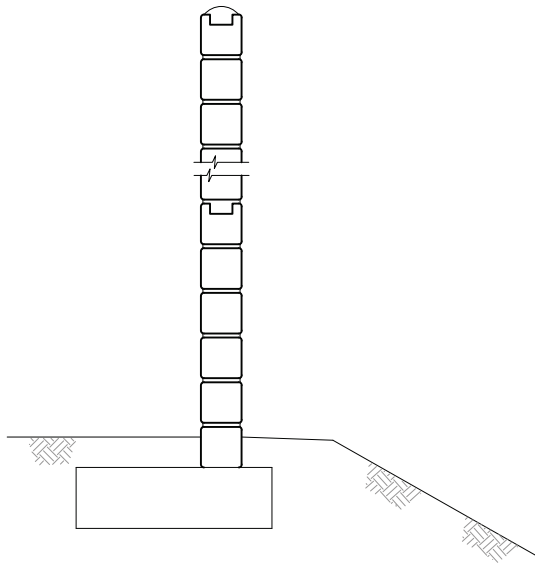

TYPE 1 1
N.T.S. -

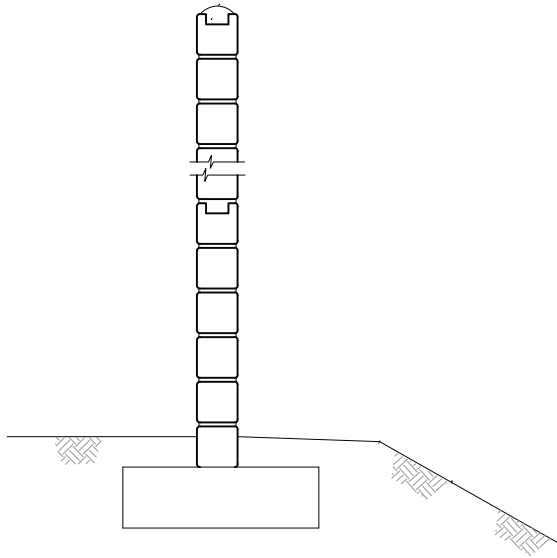

TYPE 2 2
N.T.S. -

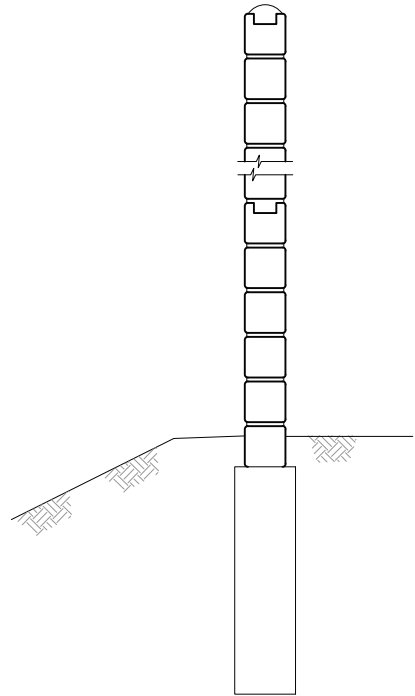

TYPE 3 3
N.T.S. -

REFER TO STANDARD PLANS FOR PUBLIC WORKS CONSTRUCTION
FOR REINFORCED CONCRETE BLOCK WALL, STANDARD PLAN 601-3

APPROVED BY:
GSWC STANDARDS COMMITTEE

Alison Sweet

EDC MANAGER

6/15/26
DATE



Golden State
Water Company

A Subsidiary of American States Water Company

TITLE:

REINFORCED CONCRETE
BLOCK WALL

SCALE:	DATE:	REV	STANDARD DWG NO.
NONE	02/04/26	2026	C-3A

ITEM	DESCRIPTION
①	8"x8"x16" concrete block (solid grout all cells)
②	Cold joint strip
③	7'-4"x5'-4"x4" concrete pad
④	Fire hydrant
⑤	8"x8"x16" cap block
⑥	#4 rebar, typical. See note 2. Rebar shall conform to ASTM A615, grade 60.
⑦	Concrete footing, Class 560-C-3250 per SSPWC section 201

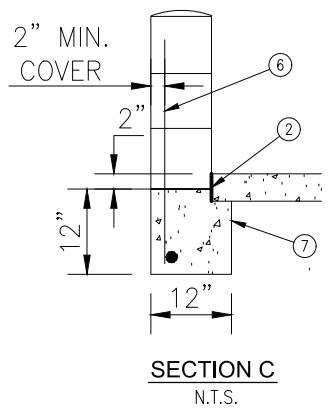
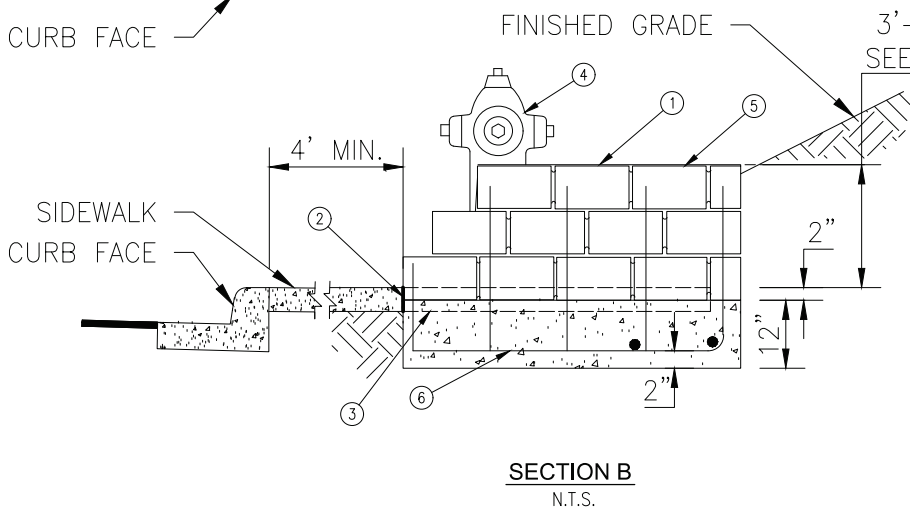
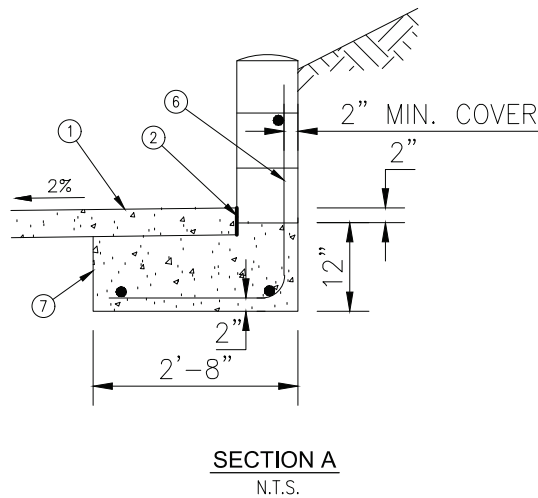
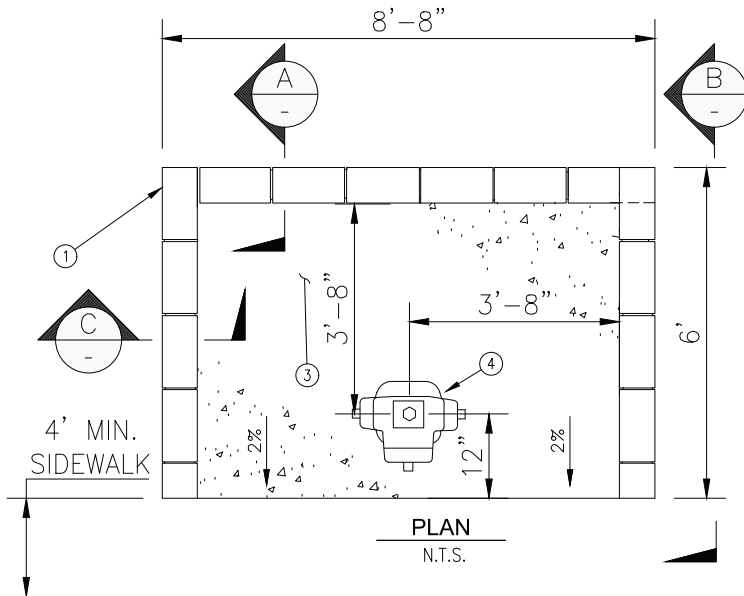

NOTES:

1. Retaining walls shall be installed where shown on the plans or as directed by the GSWC engineer.
2. Vertical bars to be installed at 16" O.C.
3. Retaining walls in excess of 3'-2" shall be designed by the engineer of work.
4. Submit block style and color for pre-approval by the utility.
5. A 36" clearance shall be maintained of any obstruction from the fire hydrant to the wall.
6. Omit mortar from vertical joint of first block course above finished grade to provide weep holes for sub-drainage purposes.

APPROVED BY:
GSWC STANDARDS COMMITTEE

Alison Sweet
EDC MANAGER

6/15/26
DATE



Golden State
Water Company
A Subsidiary of American States Water Company

TITLE:
RETAINING WALL FOR FIRE HYDRANT
AND OTHER WATER APPURTENANCES

SCALE:	DATE:	REV	STANDARD DWG NO.
NONE	11/20/25	2026	C-3B

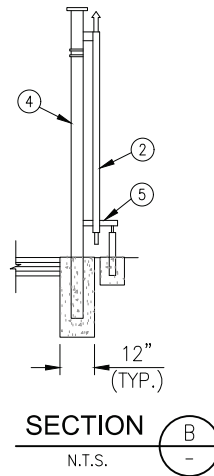
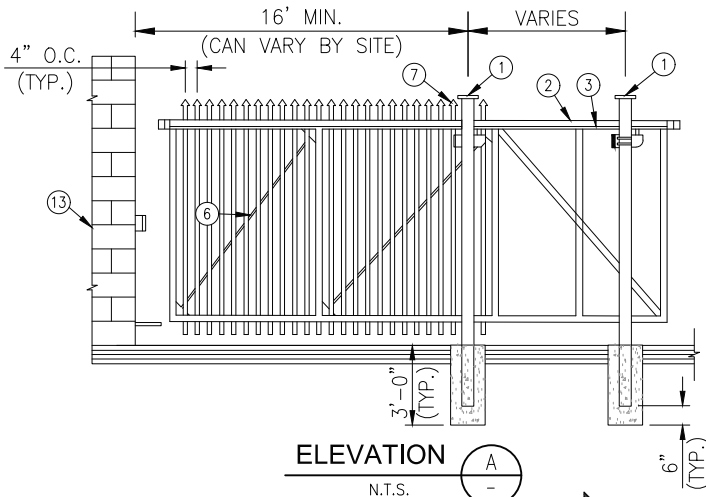

NOTES:

1. Specific fence and gate design and detail shall be submitted as a shop drawing.
2. Curved tines can be used if shown on the shop drawings.
3. All steel fence pieces shall be powder coated black.

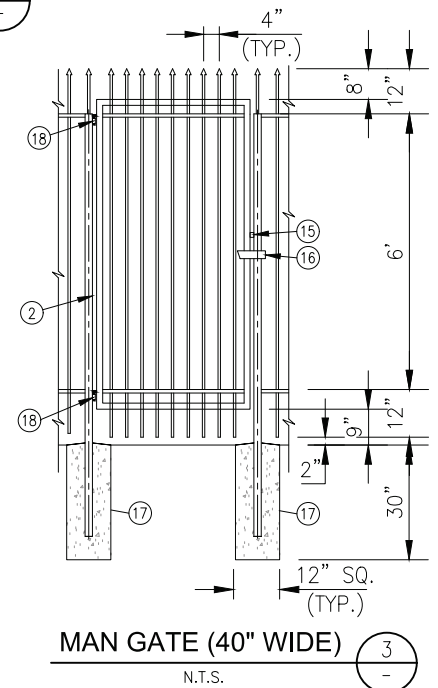
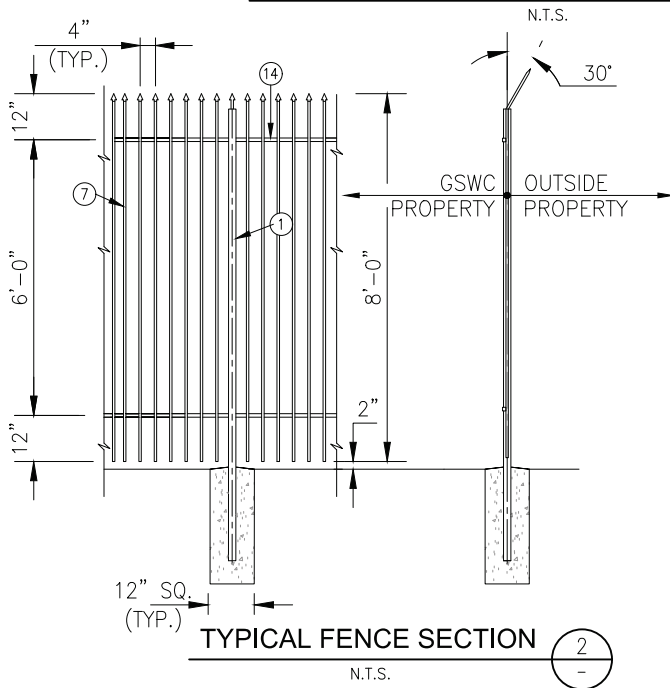
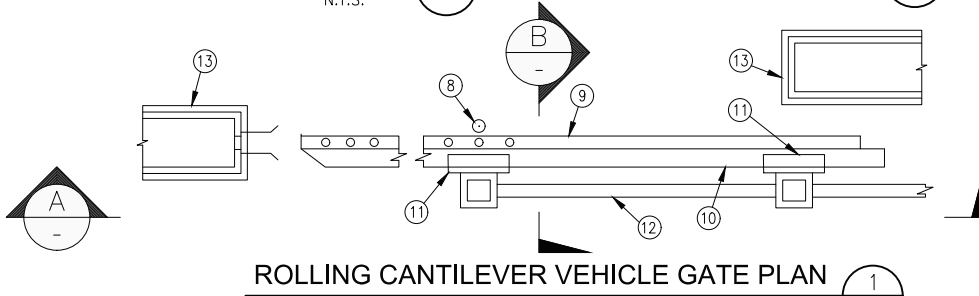

ITEM	DESCRIPTION	ITEM	DESCRIPTION
①	Fence posts, 4" square, 3/16" wall (6' o.c. max.)	⑩	Track
②	Gate frame, 2" square, 14 GA.	⑪	Trolley
③	Track	⑫	Fence line
④	Carriage post, 4" square, 3/16" wall	⑬	Perimeter fence/wall
⑤	Guide Rollers	⑭	Steel tube horizontal bar, 1 1/2" sq., 16 GA
⑥	1/4"x3/4" truss rod	⑮	Padlock hasps
⑦	1-1/8" square, 16 GA. picket	⑯	Drop latch
⑧	Rollers	⑰	Concrete footing
⑨	Gate, width will vary depending on site	⑱	Hinge

APPROVED BY:
GSWC STANDARDS COMMITTEE

Alison Sweet

EDC MANAGER

6/15/26
DATE



Golden State
Water Company

A Subsidiary of American States Water Company

TITLE:

STEEL TUBE FENCE
AND GATE

SCALE:
NONE

DATE:
07/31/23

REV
2024

STANDARD DWG NO.
C-4A

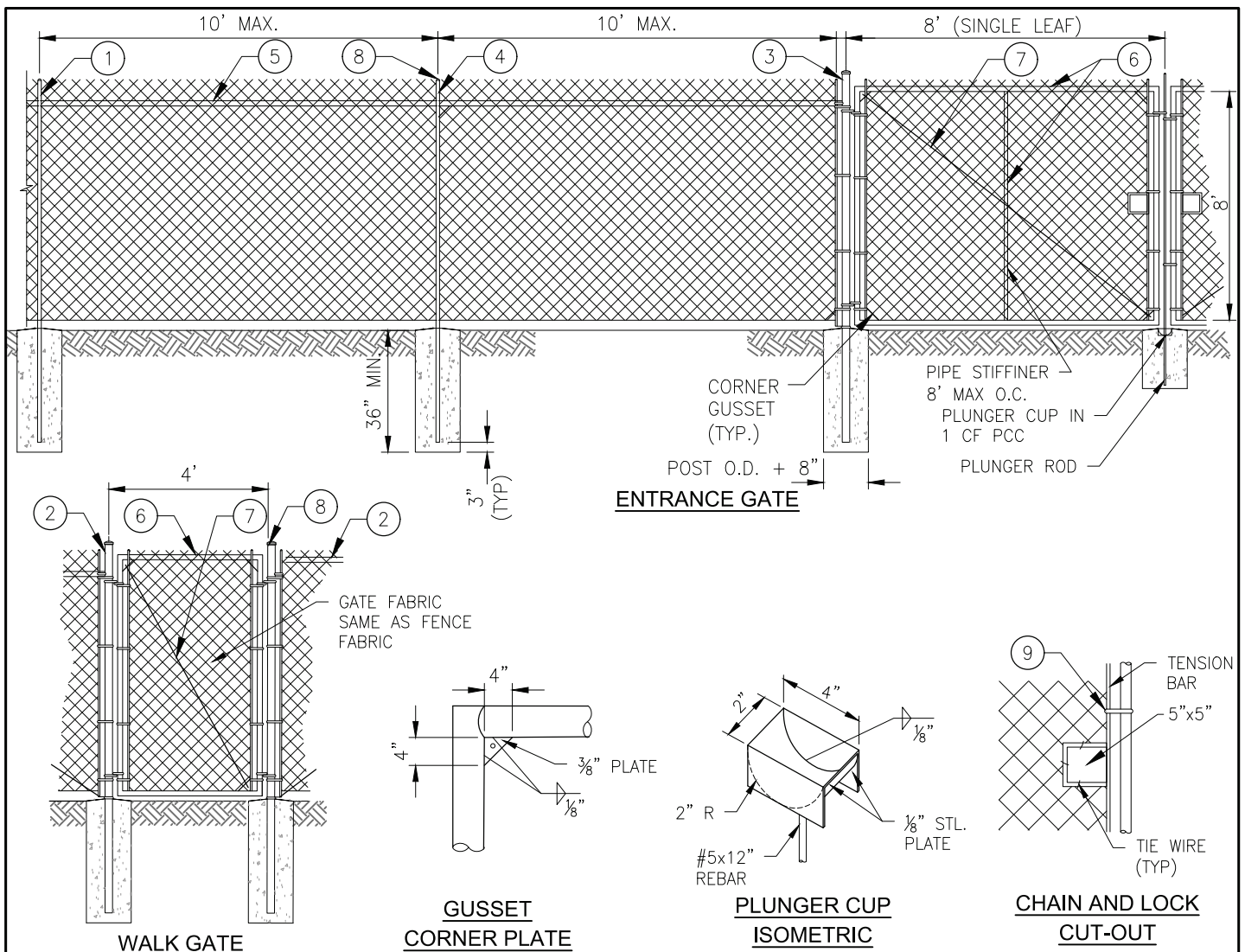

CHAIN LINK FENCE AND GATE

NOTES:

1. Specific fence and gate design and detail shall be submitted as a shop drawings.
2. Chain link fence and gates shall have 2" vinyl slats, colored.
3. All posts and hardware shall be galvanized.
4. All chain link fencing to be provided with top rails.

ITEM	DESCRIPTION
①	Corner and End Posts (10' o.c. max) 2 1/2" NPS (2.875")
②	Walk Gate Posts 3" NPS (3.5")
③	Entrance Swing Gate Posts 6" NPS (6.625")
④	Line Posts (Intermediate) 2" NPS (2.375")
⑤	Top Rails and Braces 1 1/4" NPS (1.660")
⑥	Frames for Gates 1 1/2" NPS (1.900")
⑦	Tension Rod and Tightener for gates 3/8" threaded rod with tightener
⑧	Fence post cap (galvanized) drive fit and screw retained
⑨	Steel bonds (galvanized) at tension bars (1/8"x1", 16" o.c.)

APPROVED BY:
GSWC STANDARDS COMMITTEE

Alison Sweet

EDC MANAGER

6/15/26
DATE



Golden State
Water Company

A Subsidiary of American States Water Company

TITLE:

**CHAIN LINK FENCE
AND GATE**

SCALE: NONE	DATE: 12/01/25	REV 2026	STANDARD DWG NO. C-4B
----------------	-------------------	-------------	--------------------------

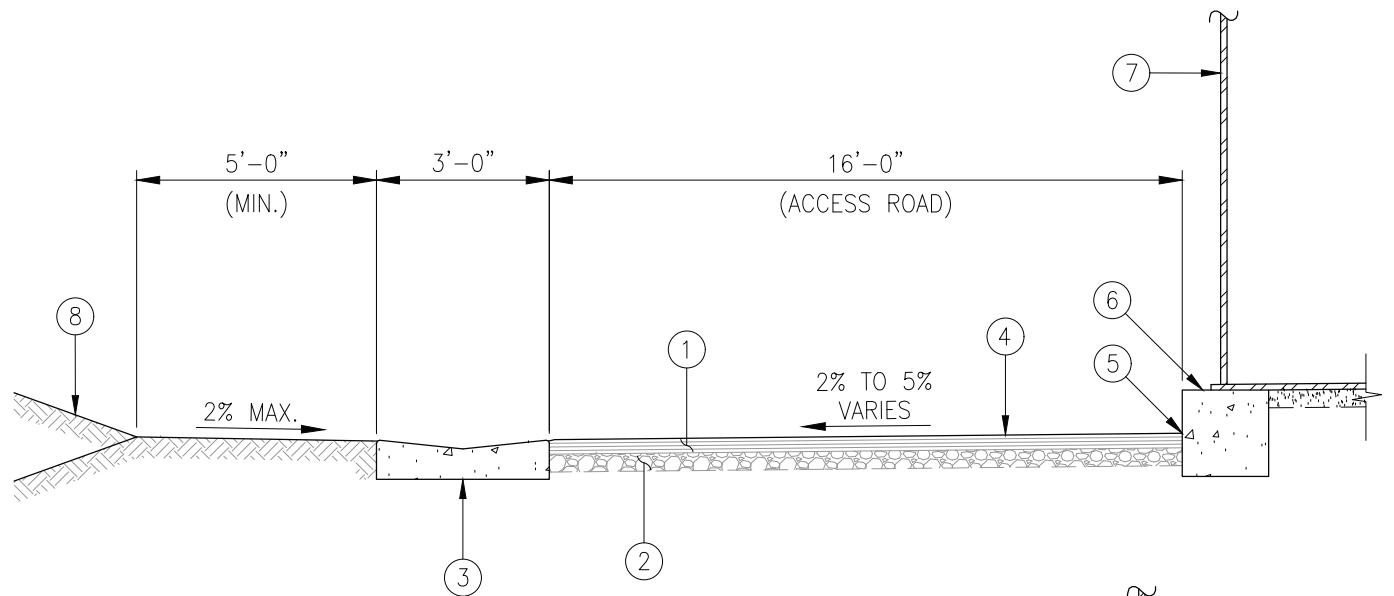

OPTION 1

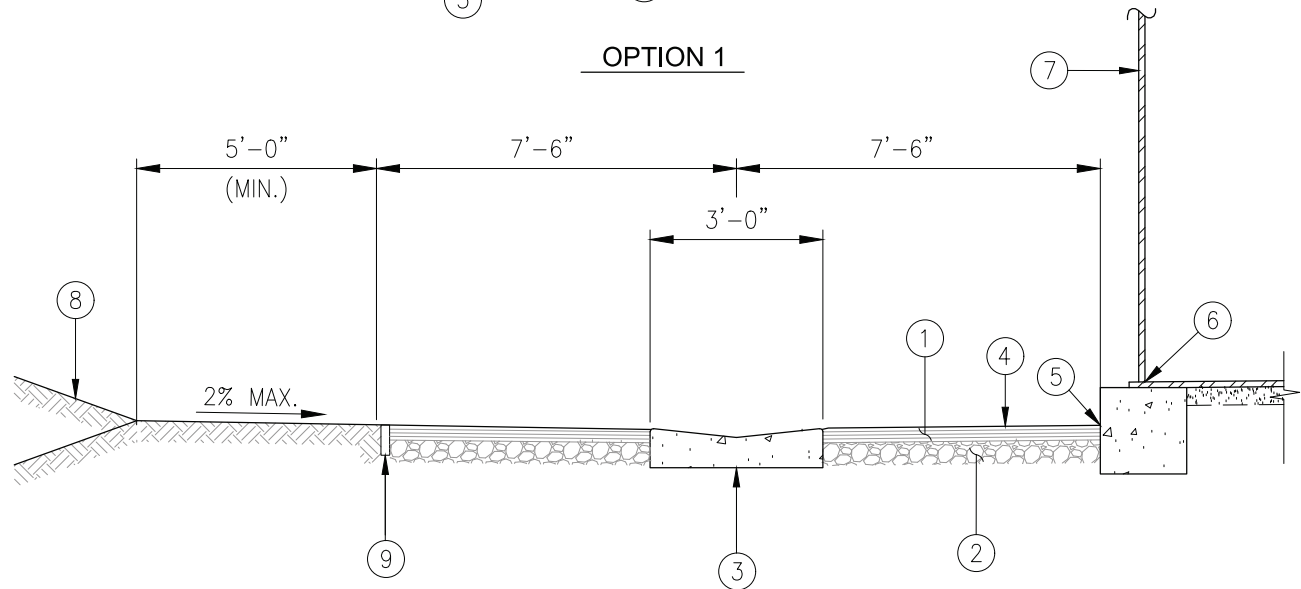

OPTION 2

ITEM	DESCRIPTION
(1)	3" A.C. min. thickness
(2)	6" Class 2 A.B. min. thickness
(3)	Concrete Alley Gutter per GSWC Std. Dwg. No. C-6
(4)	Finished surface
(5)	Finished surface elevation (varies) as shown on the plans
(6)	Top of ringwall or building foundation per plans
(7)	Tank shell or building wall
(8)	Cut slope or fill slope per geotech recommendations. Soil compacted to 90% relative density.
(9)	2"x6" redwood header

APPROVED BY:
GSWC STANDARDS COMMITTEE

Alison Sweet

EDC MANAGER

6/15/26
DATE



Golden State
Water Company

A Subsidiary of American States Water Company

TITLE:

TYPICAL SITE PAVING

SCALE:
NONE

DATE:
07/31/23

REV
2024

STANDARD DWG NO.
C-5

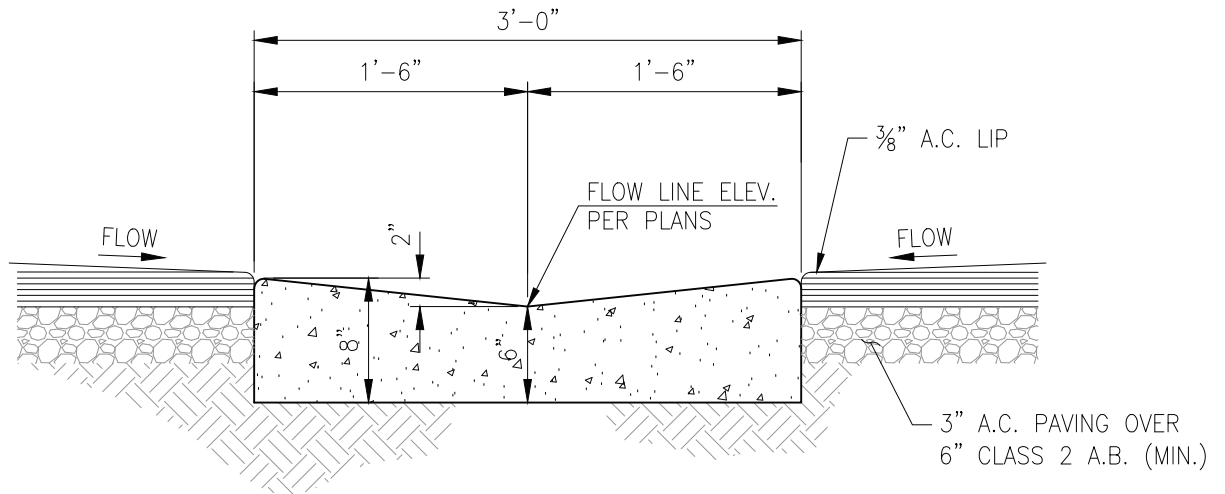

NOTES:

1. Total vertical distance from top of A.C. to flow line of Alley Gutter is 0.20' which includes the 2" depression of the Alley Gutter plus 3/8" A.C. lip.

APPROVED BY:
GSWC STANDARDS COMMITTEE

Alison Sweet

EDC MANAGER

6/15/26
DATE



Golden State
Water Company

A Subsidiary of American States Water Company

TITLE:

CONCRETE ALLEY GUTTER

SCALE:
NONE

DATE:
07/31/23

REV
2024

STANDARD DWG NO.
C-6

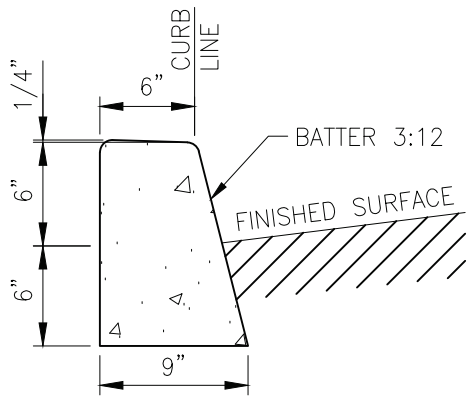

TYPE "A"

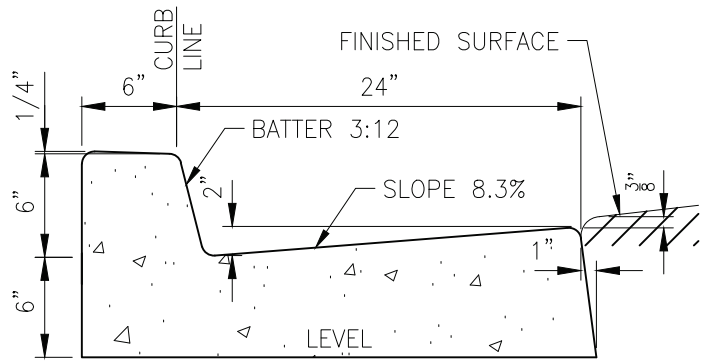

TYPE "B"

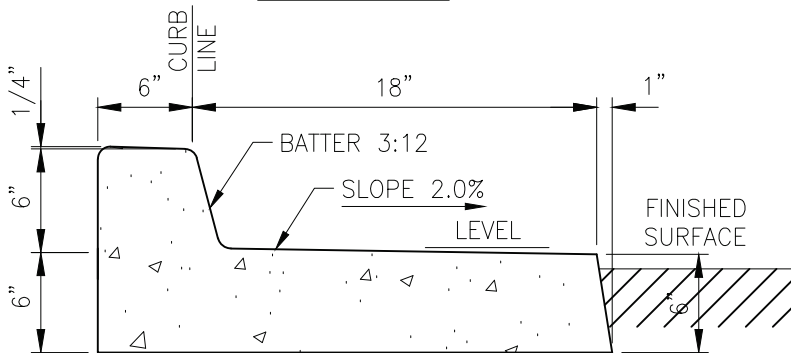

TYPE "C"
(FORWARD SLOPING)

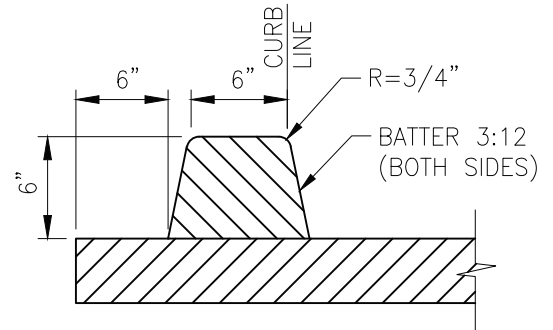

TYPE "D"
(A.C. CONSTRUCTION)

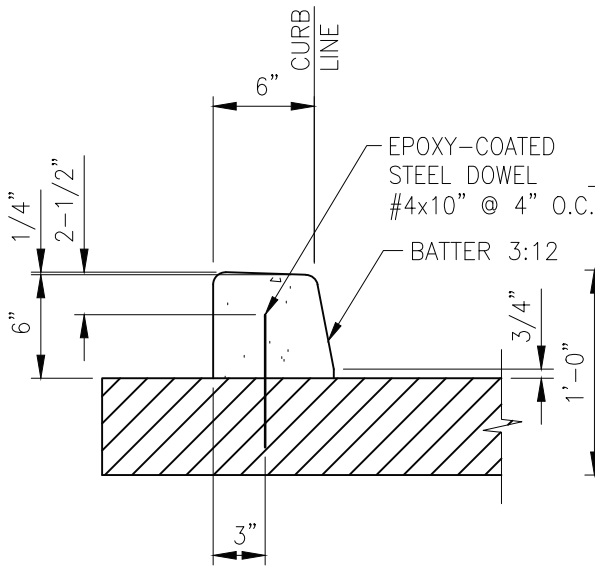

TYPE "E"
(P.C.C. CONSTRUCTION)

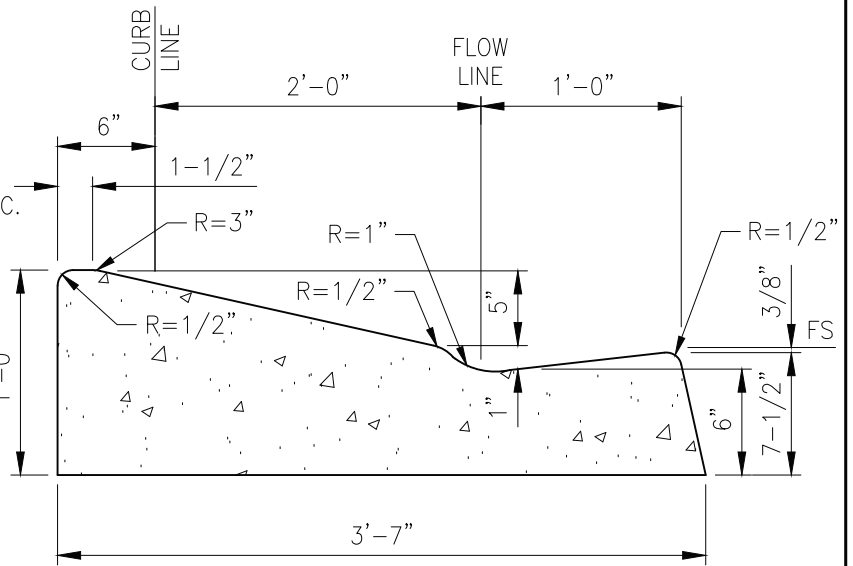

TYPE "F"
(ROLLED CURB & GUTTER)

NOTES:

1. Type B and F curb and gutter shall have AC pavement $\frac{3}{8}$ " above lip for proper drainage.
2. Type C curb and gutter shall have AC pavement $\frac{3}{8}$ " below lip for proper drainage.

APPROVED BY:
GSWC STANDARDS COMMITTEE

Alison Sweet

EDC MANAGER

6/15/26
DATE



Golden State
Water Company

A Subsidiary of American States Water Company

TITLE:

CONCRETE CURB AND
CURB & GUTTER

SCALE:
NONE

DATE:
07/31/23

REV
2024

STANDARD DWG NO.
C-7

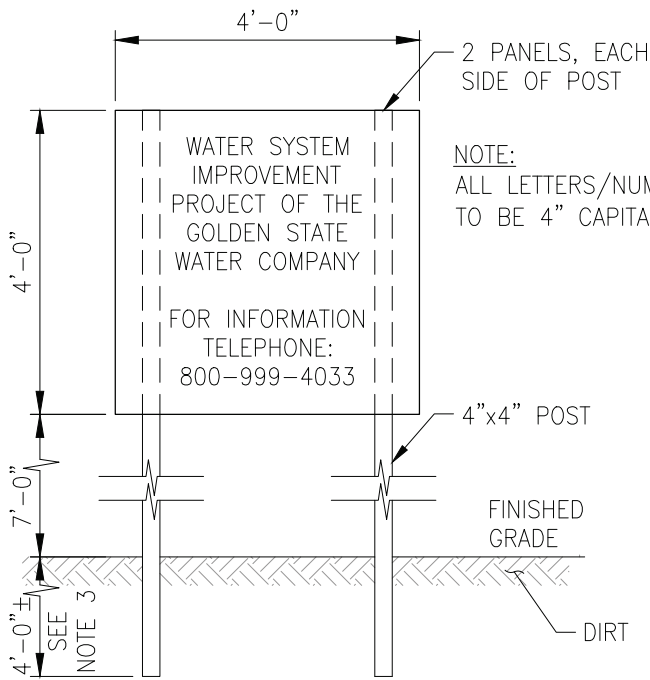

NOTE:
ALL LETTERS/NUMBERS
TO BE 4" CAPITALS

NOTES:

1. Sign panels shall be of sheet aluminum material 0.08-inch thick. Thickness, finish and structural integrity to conform to City, County and State standards and requirements.
2. Posts and skids shall be of treated/painted wood material. Dimensions, finish and structural integrity to conform to City, County and State standards and requirements.
3. Posts shall be either embedded into the ground with any needed support or anchoring or mounted on skids to meet City, County or State standards.
4. Signs shall be located within public right of way, and not interfere with the pedestrian or traffic flow.
5. Sign details – White background with reflective surface
– Permanent lettering to be bold, block letters in GSWC dark blue

ALTERNATIVE "A"

SIGN (2 PANELS) MOUNTED ON 2 POSTS
EMBEDDED IN THE GROUND

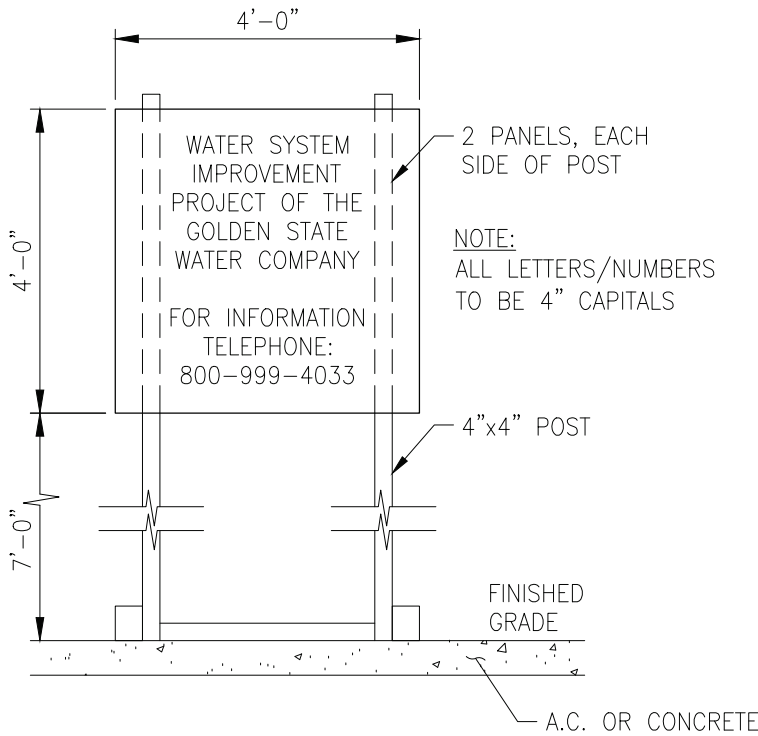

NOTE:
ALL LETTERS/NUMBERS
TO BE 4" CAPITALS

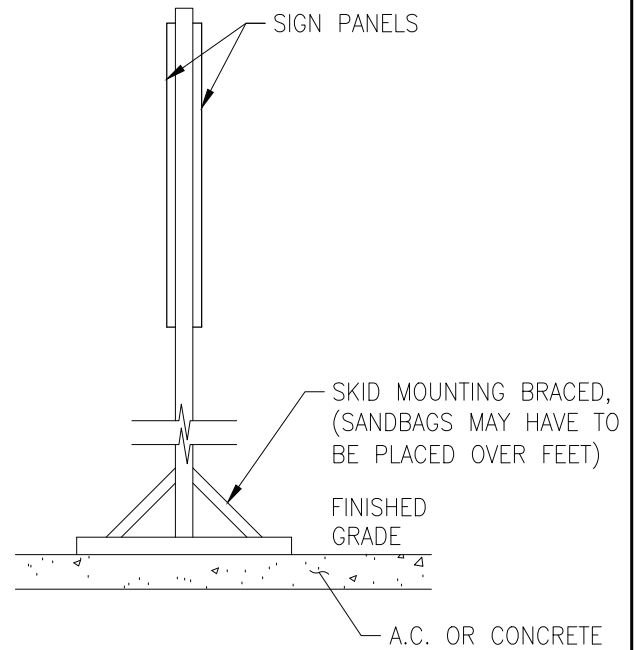

FRONT VIEW

SIDE VIEW

ALTERNATIVE "B"

SIGN (2 PANELS) MOUNTED ON 2 POSTS
AFFIXED WITH BOLTS TO SKID TYPE FEET

APPROVED BY:
GSWC STANDARDS COMMITTEE

Alison Sweet

EDC MANAGER

6/15/26
DATE



Golden State
Water Company

A Subsidiary of American States Water Company

TITLE:

PROJECT INFORMATION SIGN

SCALE:
NONE

DATE:
07/31/23

REV
2024

STANDARD DWG NO.
C-8

NOTE:

LUBRICATE IN-GROUND PORTION OF THE PIPE TO PREVENT ADHESION TO THE SLEEVE

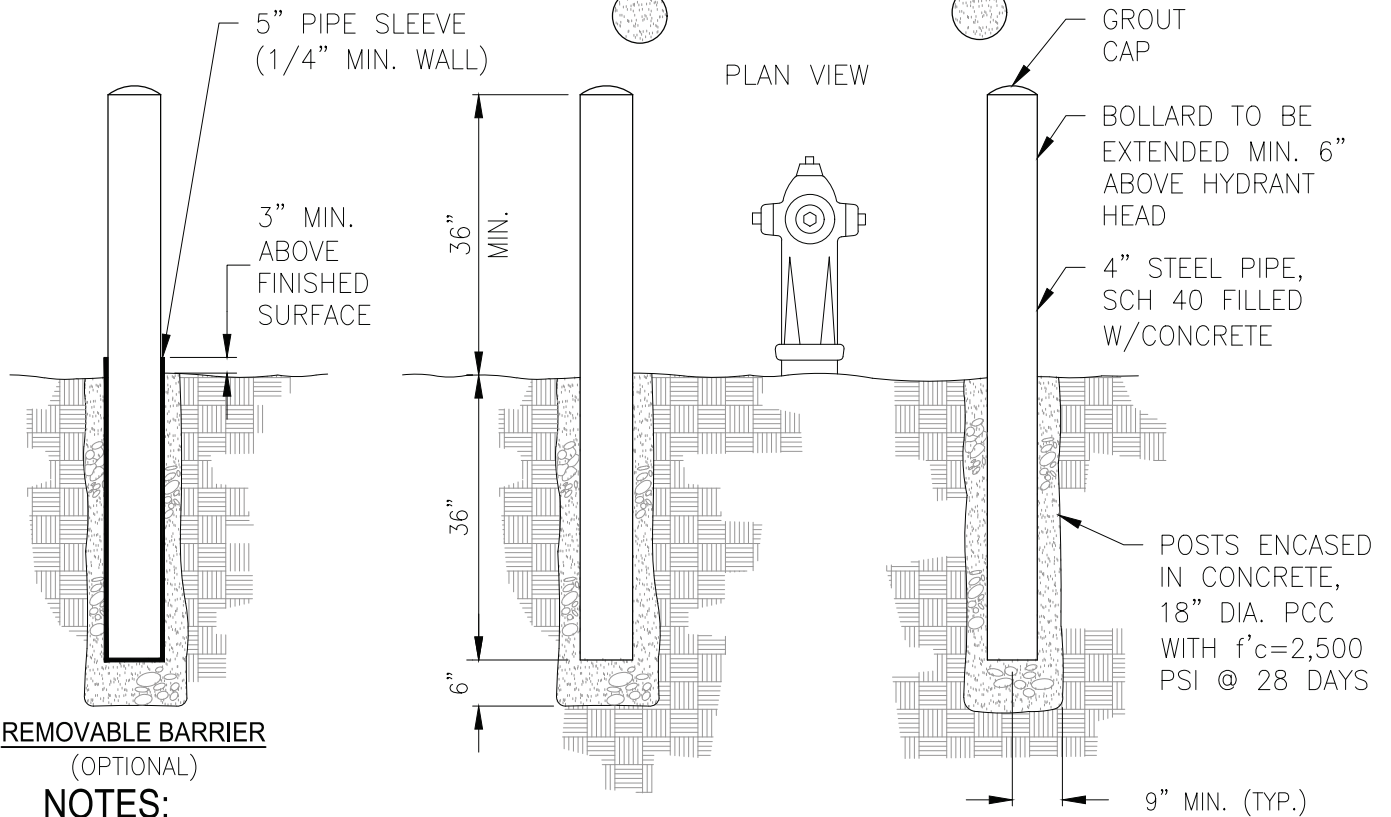

NOTES:

1. Orientation of barricade may be changed according to field conditions.
2. Bollard coating color per local fire department requirements.
 - A. in lieu of painting, a protective polyethylene sleeve may be put over steel post colored to meet local fire department requirements.
3. Coating material shall be per GSWC painting specifications for above grade steel piping.
 - A. A polyethylene encased steel post (Sch. 40 pipe) may be used instead of a painted post.
4. See Potable Water Material Guidelines for acceptable manufacturers.
5. Wrightwood CSA shall have 5' tall barricades.

APPROVED BY:
GSWC STANDARDS COMMITTEE

Alison Sweet

EDC MANAGER

6/15/26
DATE



Golden State
Water Company

A Subsidiary of American States Water Company

TITLE:

VEHICLE BARRICADE

SCALE:
NONE

DATE:
11/19/25

REV
2026

STANDARD DWG NO.
C-9

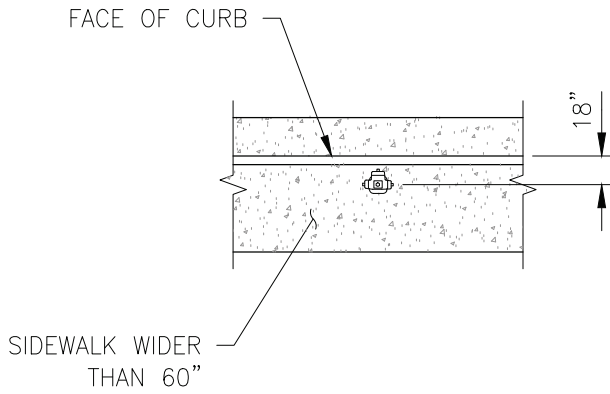

CONDITION 1
(IN THE SIDEWALK)

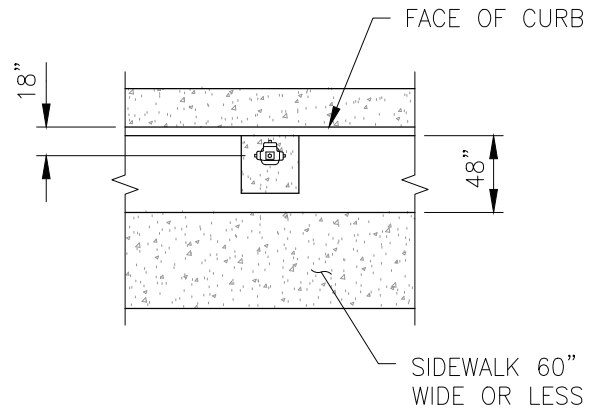

CONDITION 3
(IN THE PARKWAY)

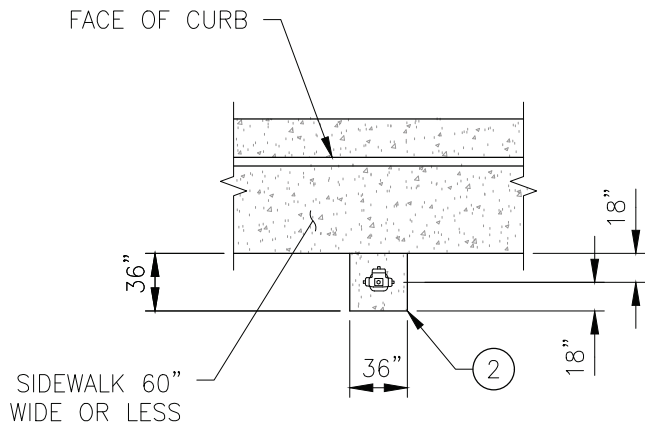

CONDITION 2
(BEHIND THE SIDEWALK)

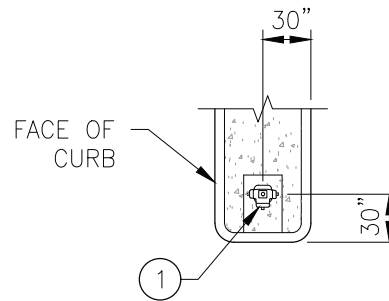

CONDITION 3
(IN THE PARKING LOT)

MATERIALS:

- ① Residential hydrant with (1) 4" and (1) 2 ½" fire hose outlets. Non-residential hydrant with (2) 4" and (1) 2 ½" fire hose outlets.
- ② Construct concrete pad per GSWC Std. Dwg. Nos. P-8 and P-9.

NOTES:

- 1. See GSWC Std. Dwg. No. P-8 and P-9 for fire hydrant details.
- 2. Fire hydrant shall not be placed at the same curb return occupied by a street light.

APPROVED BY:
GSWC STANDARDS COMMITTEE

Alison Sweet

EDC MANAGER

6/15/26
DATE



Golden State
Water Company

A Subsidiary of American States Water Company

TITLE:

TYPICAL FIRE HYDRANT LOCATION

SCALE:
NONE

DATE:
04/10/26

REV
2026

STANDARD DWG NO.
C-10

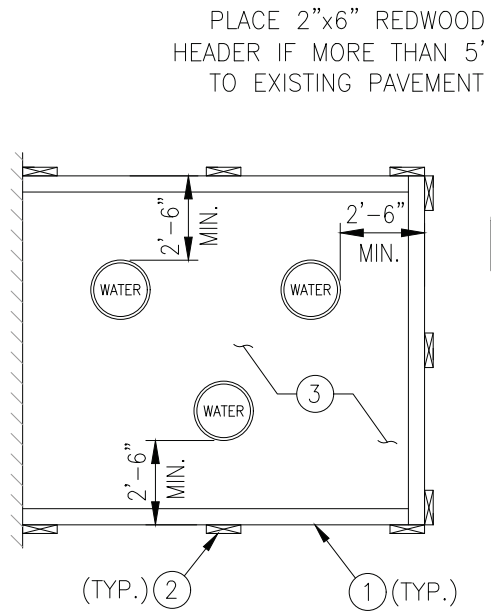

PAVING AROUND VALVE CLUSTER 2
-
N.T.S.

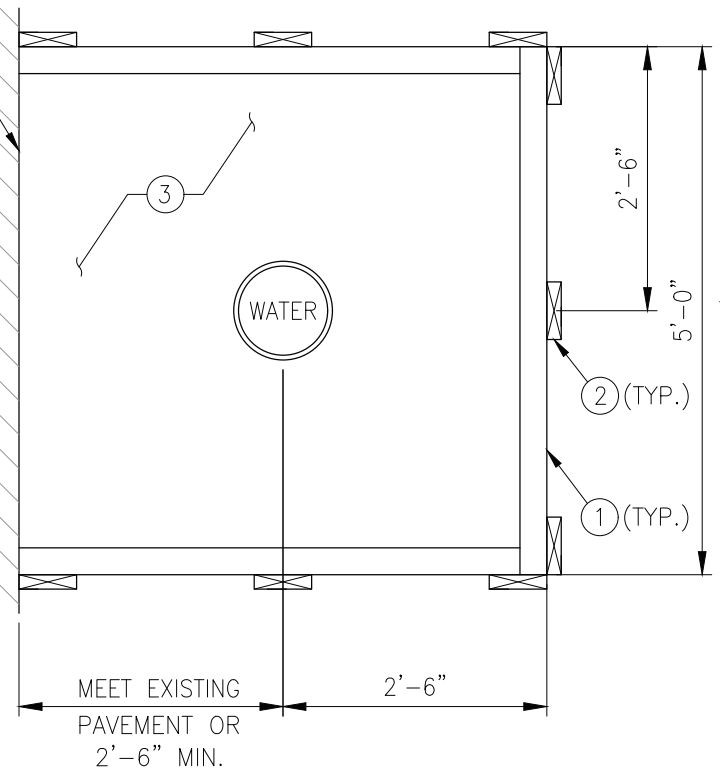

PAVING AROUND VALVES 1
-
N.T.S.

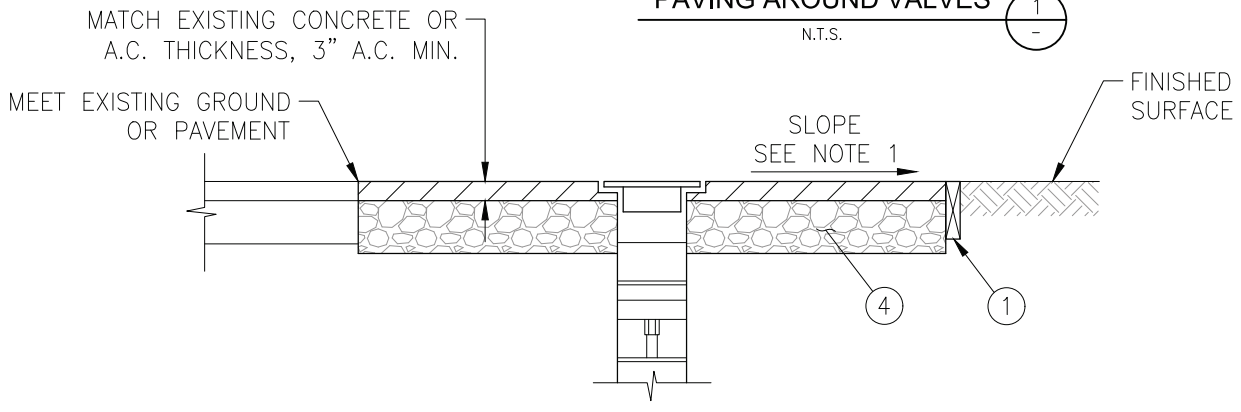

SECTION A
N.T.S. A
-

NOTE:

1. Slope will conform to governing agency road improvement standards and specifications, or meet existing conditions as directed by engineer. Pad shall be sloped away from valve lid.
2. Valves located in landscaped areas shall have a 2'x2' concrete pad installed around each valve.
3. AC or concrete pad.

ITEM	DESCRIPTION
①	2"x6" redwood headers
②	2"x4"x18" stakes (3 per side) at 30" O.C.
③	Area to be paved
④	6" of 3/4" Class 2 A.B.

APPROVED BY:
GSWC STANDARDS COMMITTEE
Alison Sweet
EDC MANAGER
6/15/26
DATE



TITLE:
PAVING AROUND VALVES (NOT IN THE PAVEMENT)

SCALE: NONE	DATE: 07/31/23	REV 2024	STANDARD DWG NO. C-11
----------------	-------------------	-------------	--------------------------

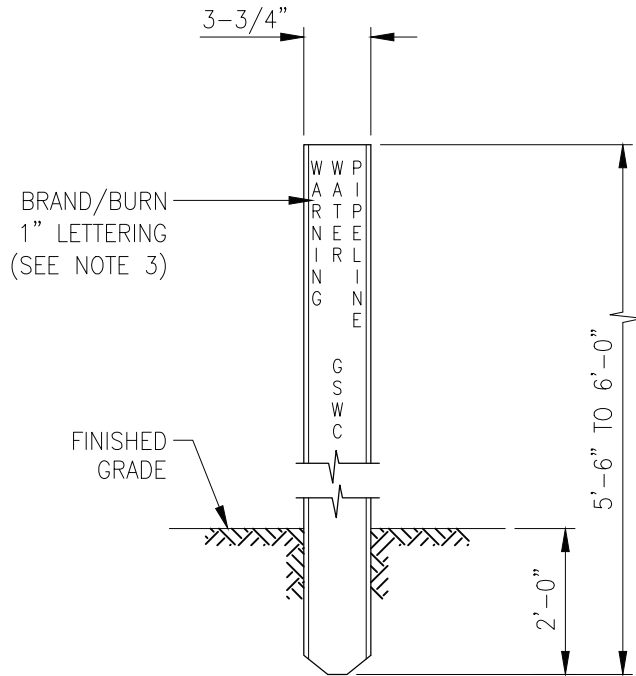

PIPELINE MARKER POST (1)
N.T.S.

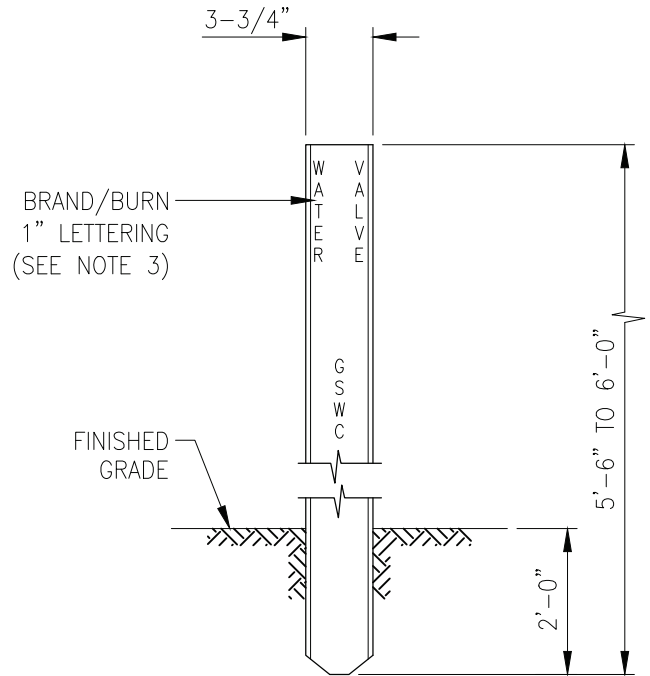

VALVE MARKER POST (2)
N.T.S.

NOTES:

1. Waterline marker post shall be installed where called for on the plans or as directed by the engineer. Spacing shall be approximately 200' between markers, curved alignments less than 800' in length shall have a minimum of four markers to define the curve.
2. Waterline marker post shall be installed 12" to the south and west of the utility.
3. Marker shall incorporate 1" high lettering branded/burned into paddle. Lettering shall include GSWC along with the utility identified. The color of the paddle shall be blue.
4. Lettering shall be white.
5. On back of marker write: "Call GSWC at (800) 999-4033" and "Before digging in this area call 811".

APPROVED BY:
GSWC STANDARDS COMMITTEE

Alison Sweet

EDC MANAGER

6/15/26
DATE



Golden State
Water Company

A Subsidiary of American States Water Company

TITLE:

**PIPELINE MARKER POST
INSTALLATION**

SCALE:
NONE

DATE:
07/31/23

REV
2024

STANDARD DWG NO.
C-12

LIGHTING FIXTURE COMPLETE WITH 1-130 LA WATT L.E.D. ARRAY, AND POLYCARBONATE LENS. BRONZE POWDER COAT FINISH TO MATCH POLE. PROVIDE INTERNAL REAR SHIELD WHERE BACK OF FIXTURE IS AGAINST PROPERTY LINE. PHOTO ELECTRIC CONTROL IS OPTIONAL BASED ON SITE AND PROJECT NEEDS.

4" SQUARE 16' HIGH STEEL POLE WITH BRONZE POWDER COAT FINISH

WEATHER PROOF RECEPTACLE (GFI)

HAND HOLE

GALVANIZED ANCHOR BOLT PER MFGRS REQUIREMENTS (TYP 4) 3/4" DIA.x30" LONG

1/2" CHAMFER

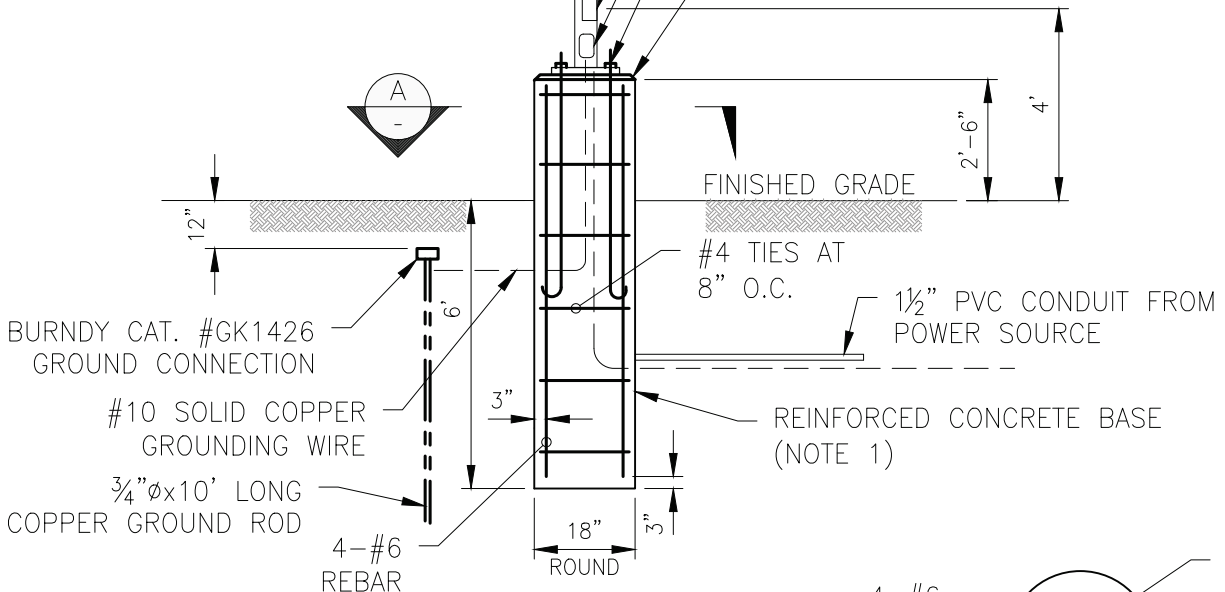

POLE MOUNTED LIGHT
N.T.S. (1)

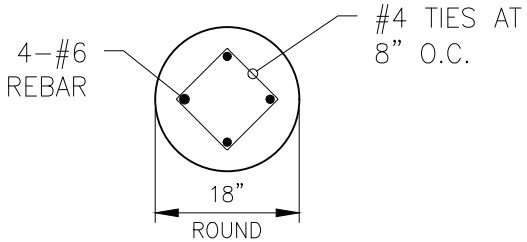

SECTION A
N.T.S. (A)

NOTES:

1. Refer to civil/structural drawings for reinforcement detail.

APPROVED BY:
GSWC STANDARDS COMMITTEE

Alison Sweet

EDC MANAGER

6/15/26
DATE



Golden State
Water Company

A Subsidiary of American States Water Company

TITLE:

POLE MOUNTED LIGHT

SCALE: NONE	DATE: 07/31/23	REV 2024	STANDARD DWG NO. C-13
----------------	-------------------	-------------	--------------------------

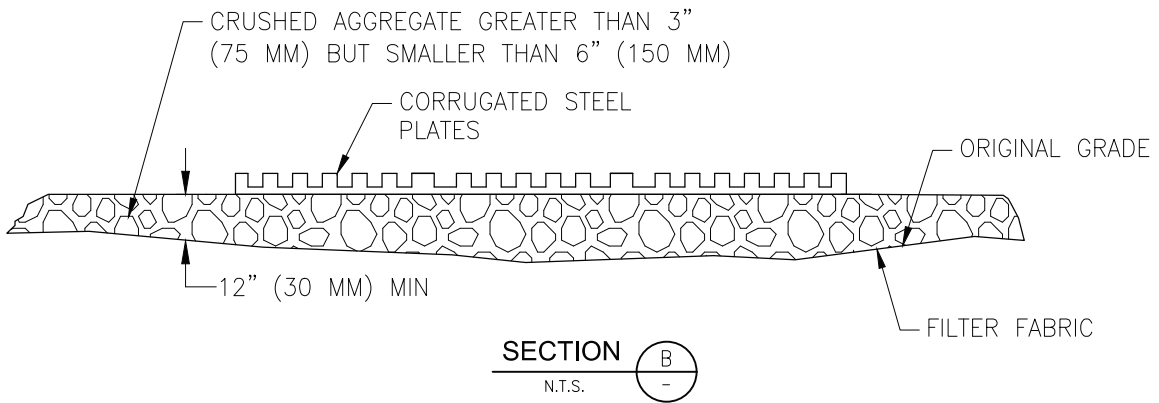
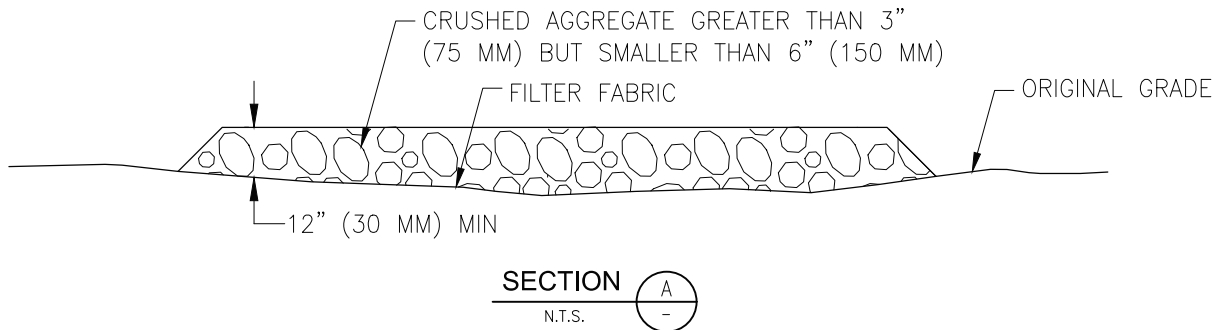
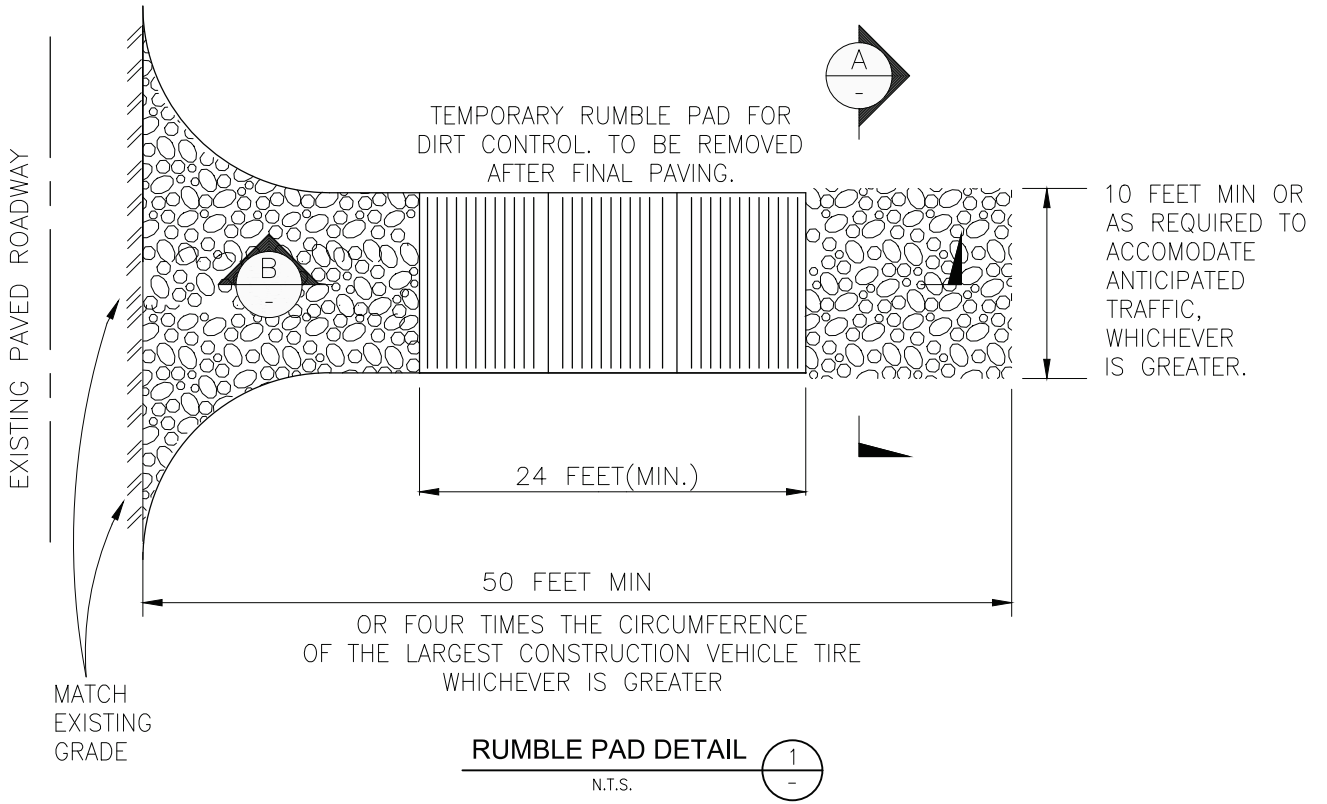

APPROVED BY:
GSWC STANDARDS COMMITTEE

Alison Sweet

EDC MANAGER

6/15/26
DATE



Golden State
Water Company
A Subsidiary of American States Water Company

TITLE:
RUMBLE PAD CONSTRUCTION
ENTRANCE-EXIT (TC1B)
BOTTOM

SCALE:	DATE:	REV	STANDARD DWG NO.
NONE	11/19/25	2026	C-14

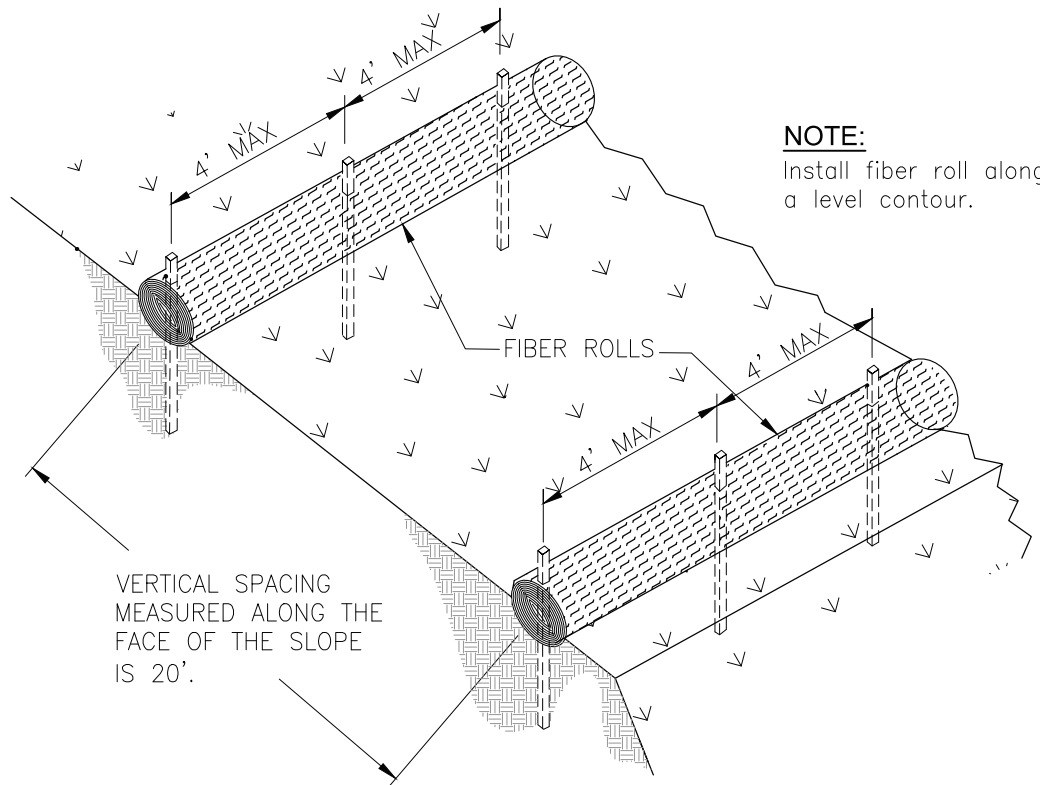

TYPICAL FIBER ROLL INSTALLATION

1
-

N.T.S.

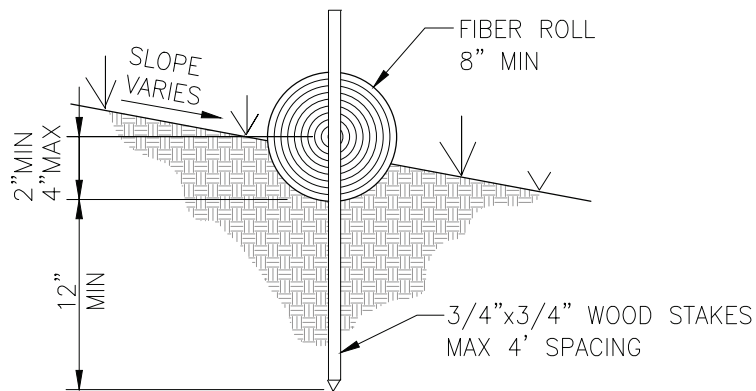

ENTRENCHMENT DETAIL

2
-

N.T.S.

APPROVED BY:
GSWC STANDARDS COMMITTEE

Alison Sweet

EDC MANAGER

6/15/26
DATE



Golden State
Water Company

A Subsidiary of American States Water Company

TITLE:

EROSION CONTROL FIBER
ROLL INSTALLATION (SC-5)

SCALE:
NONE

DATE:
07/31/23

REV
2024

STANDARD DWG NO.
C-15

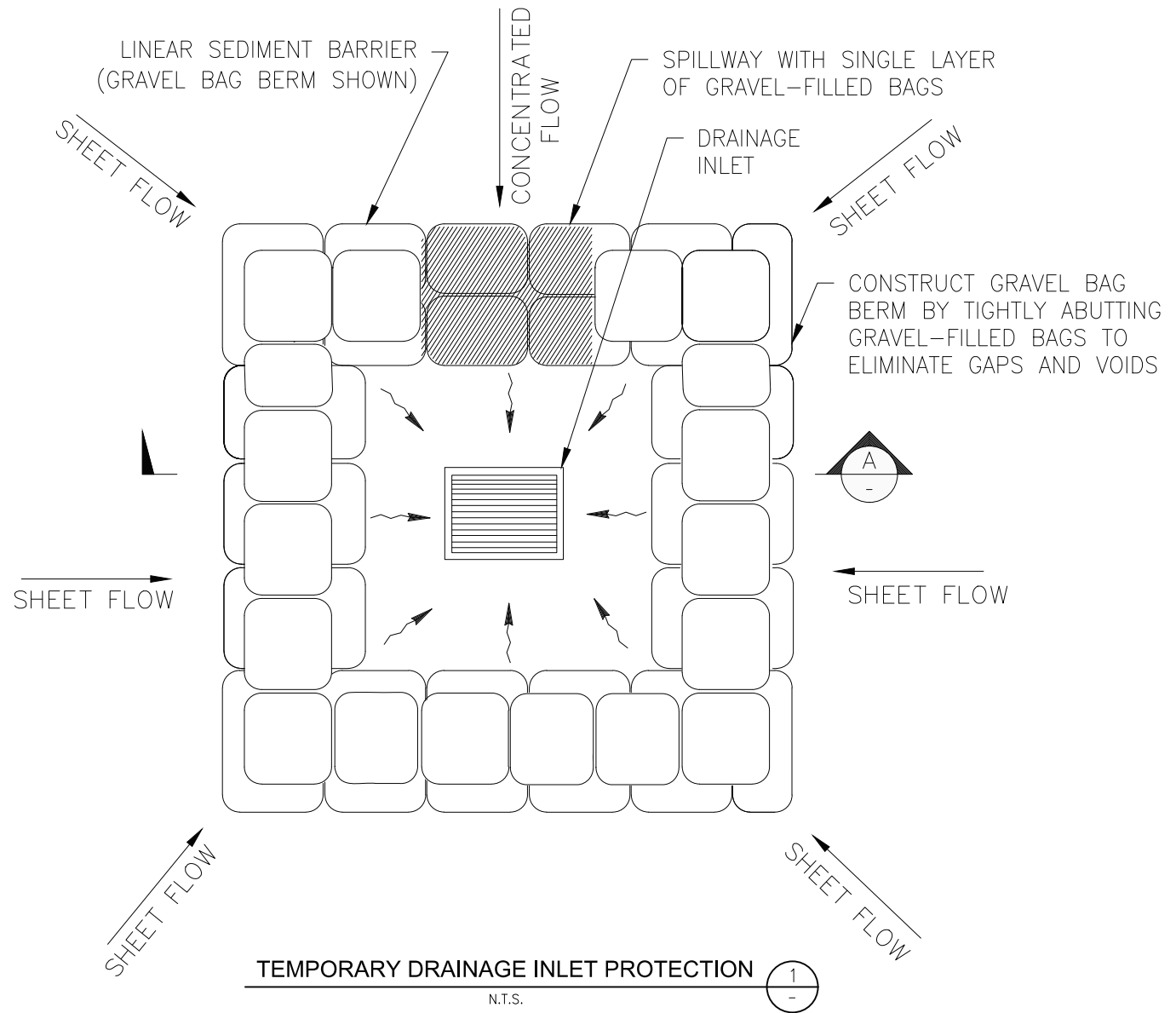
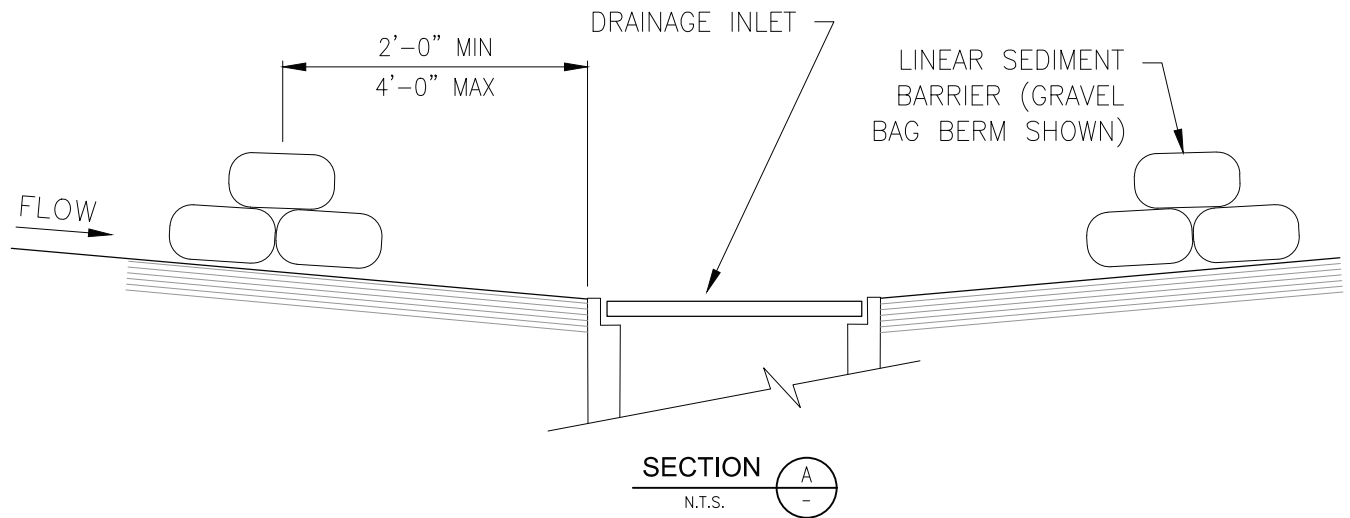

APPROVED BY:
GSWC STANDARDS COMMITTEE

Alison Sweet

EDC MANAGER

6/15/26
DATE



Golden State
Water Company

A Subsidiary of American States Water Company

TITLE:

EROSION CONTROL
TEMPORARY GRAVEL BAG BERM
INSTALLATION

SCALE:	DATE:	REV	STANDARD DWG NO.
NONE	07/31/23	2024	C-16A

GRAVEL BAG BERM (TYPE 3A) SPACING TABLE

SLOPE OF ROADWAY (PERCENT)	1 TO 3.9	4 TO 5.9	6 TO 7.9	8 TO 10	10+
INTERVAL BETWEEN BERM	100'	75'	50'	25'	12'

For slope of less than 1%, install barriers only if erosion/sediment is prevalent

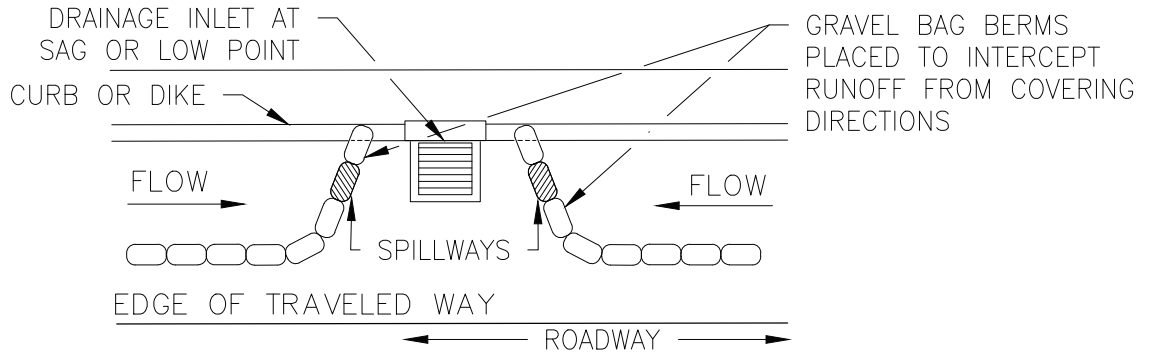

CONFIGURATION FOR SAG POINT INLET

1
-

N.T.S.

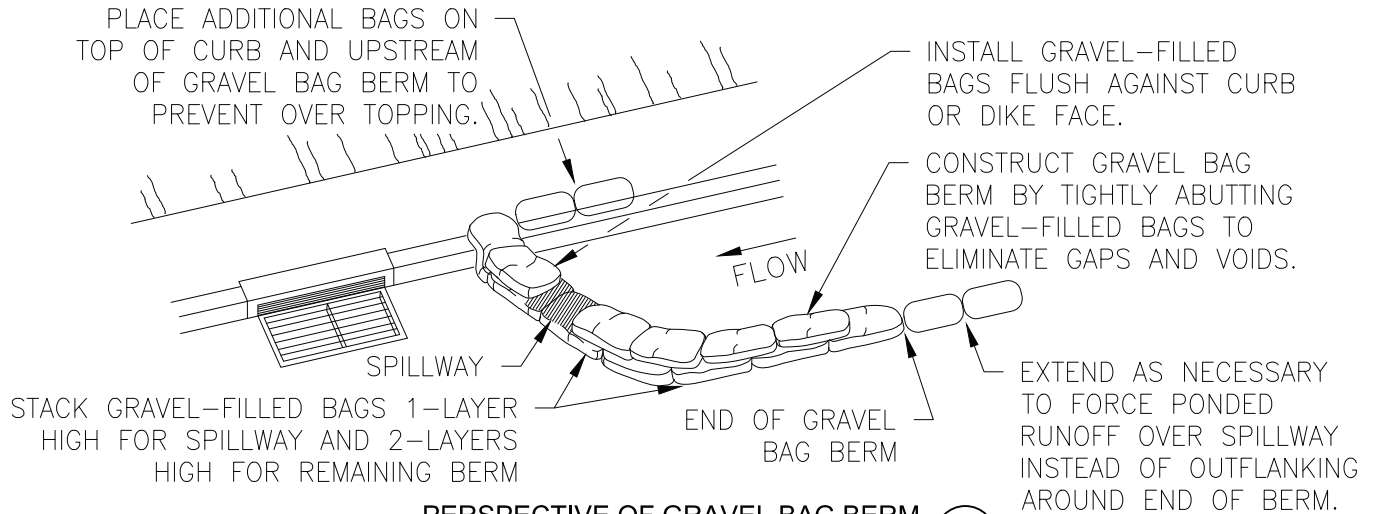

PERSPECTIVE OF GRAVEL BAG BERM

2
-

N.T.S.

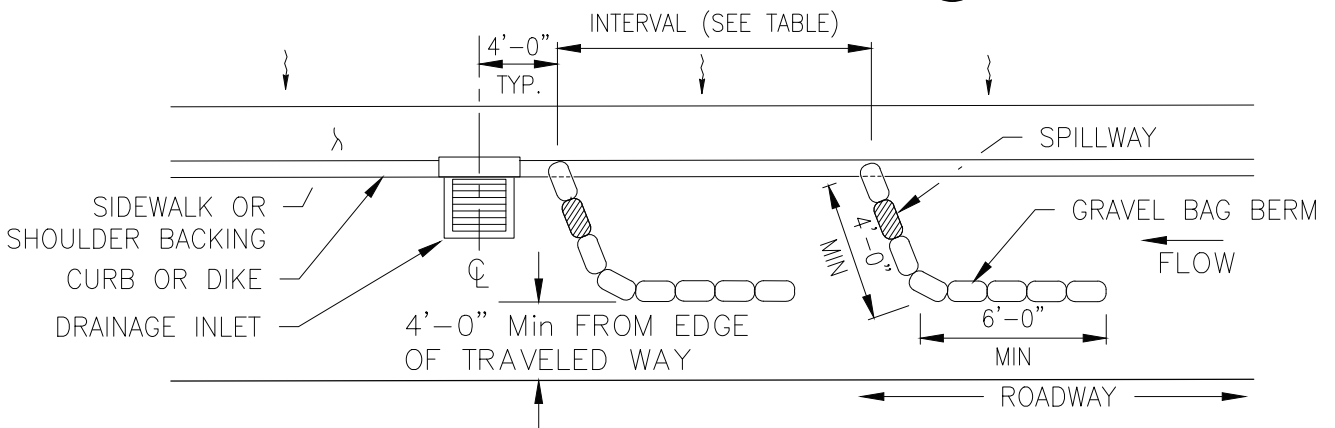

TEMPORARY DRAINAGE INLET PROTECTION

3
-

N.T.S.

APPROVED BY:
GSWC STANDARDS COMMITTEE

Alison Sweet

EDC MANAGER

6/15/26
DATE



Golden State
Water Company

A Subsidiary of American States Water Company

TITLE:

EROSION CONTROL
TEMPORARY GRAVEL BAG BERM
INSTALLATION

SCALE:
NONE

DATE:
07/31/23

REV
2024

STANDARD DWG NO.
C-16B

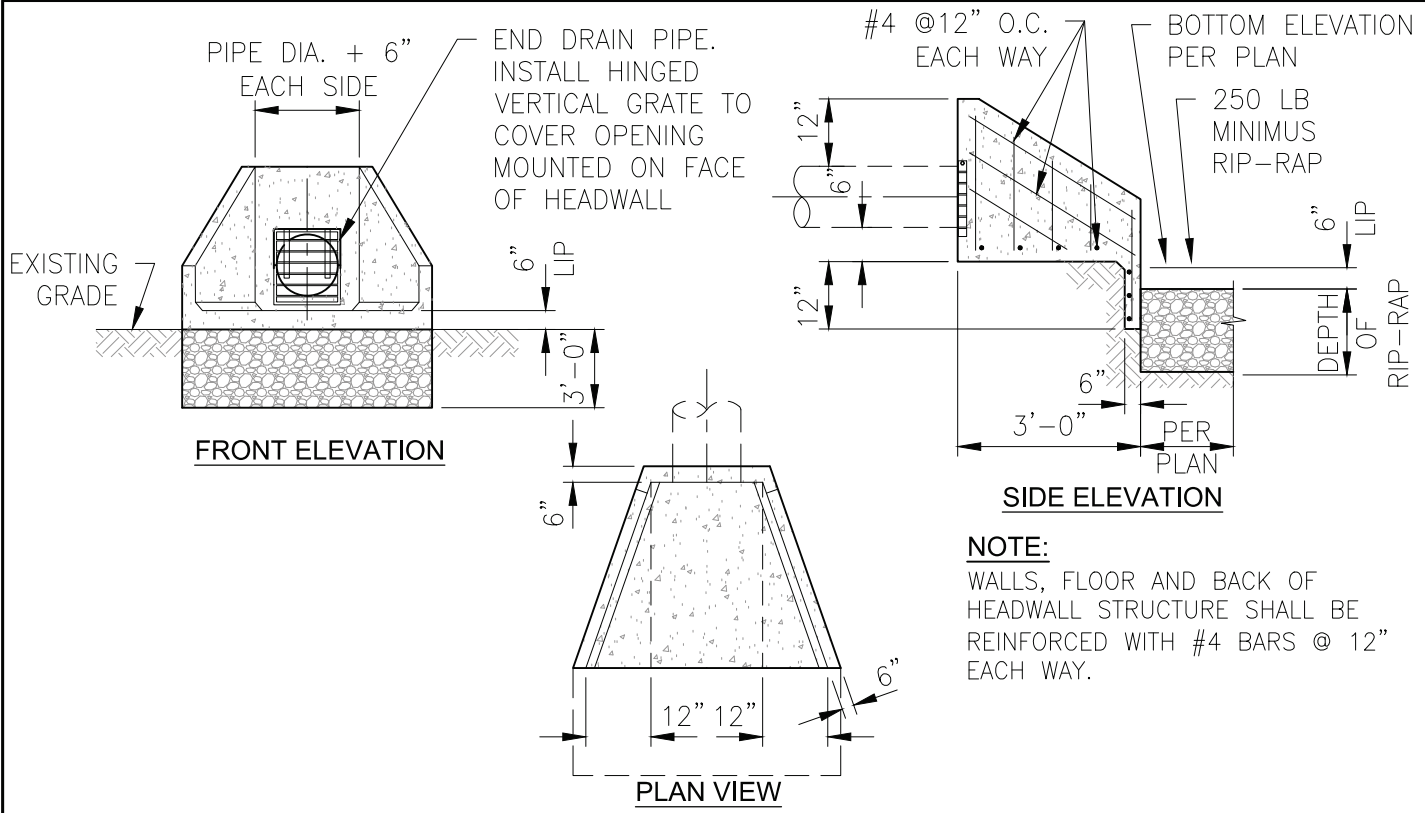

SINGLE OUTLET

NOTE:
 WALLS, FLOOR AND BACK OF HEADWALL STRUCTURE SHALL BE REINFORCED WITH #4 BARS @ 12" EACH WAY.

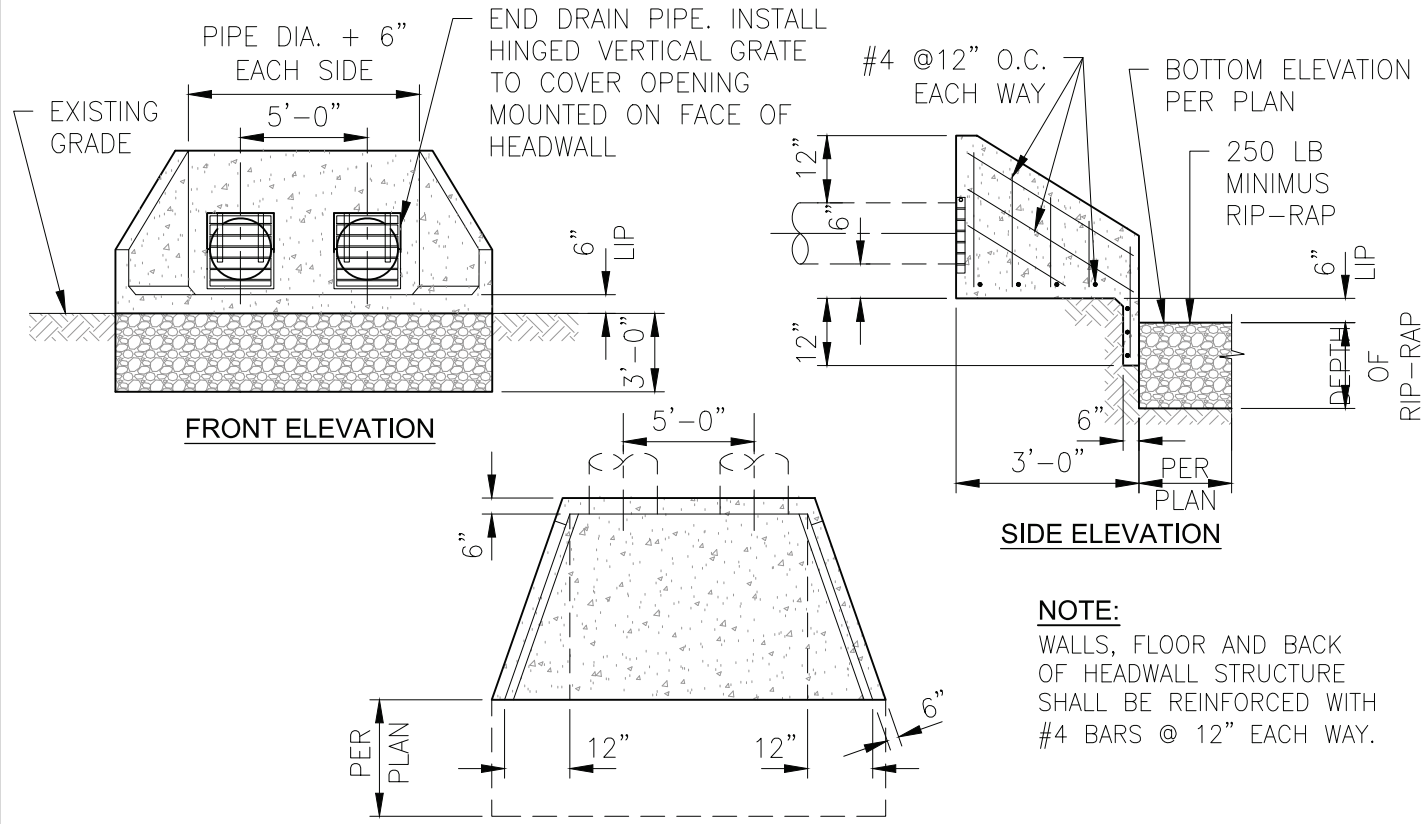

DOUBLE OUTLET

NOTE:
 WALLS, FLOOR AND BACK OF HEADWALL STRUCTURE SHALL BE REINFORCED WITH #4 BARS @ 12" EACH WAY.

APPROVED BY:
 GSWC STANDARDS COMMITTEE
Alison Sweet
 EDC MANAGER
 6/15/26
 DATE



TITLE: CONCRETE HEADWALL			
SCALE: NONE	DATE: 07/31/23	REV: 2024	STANDARD DWG NO. C-17

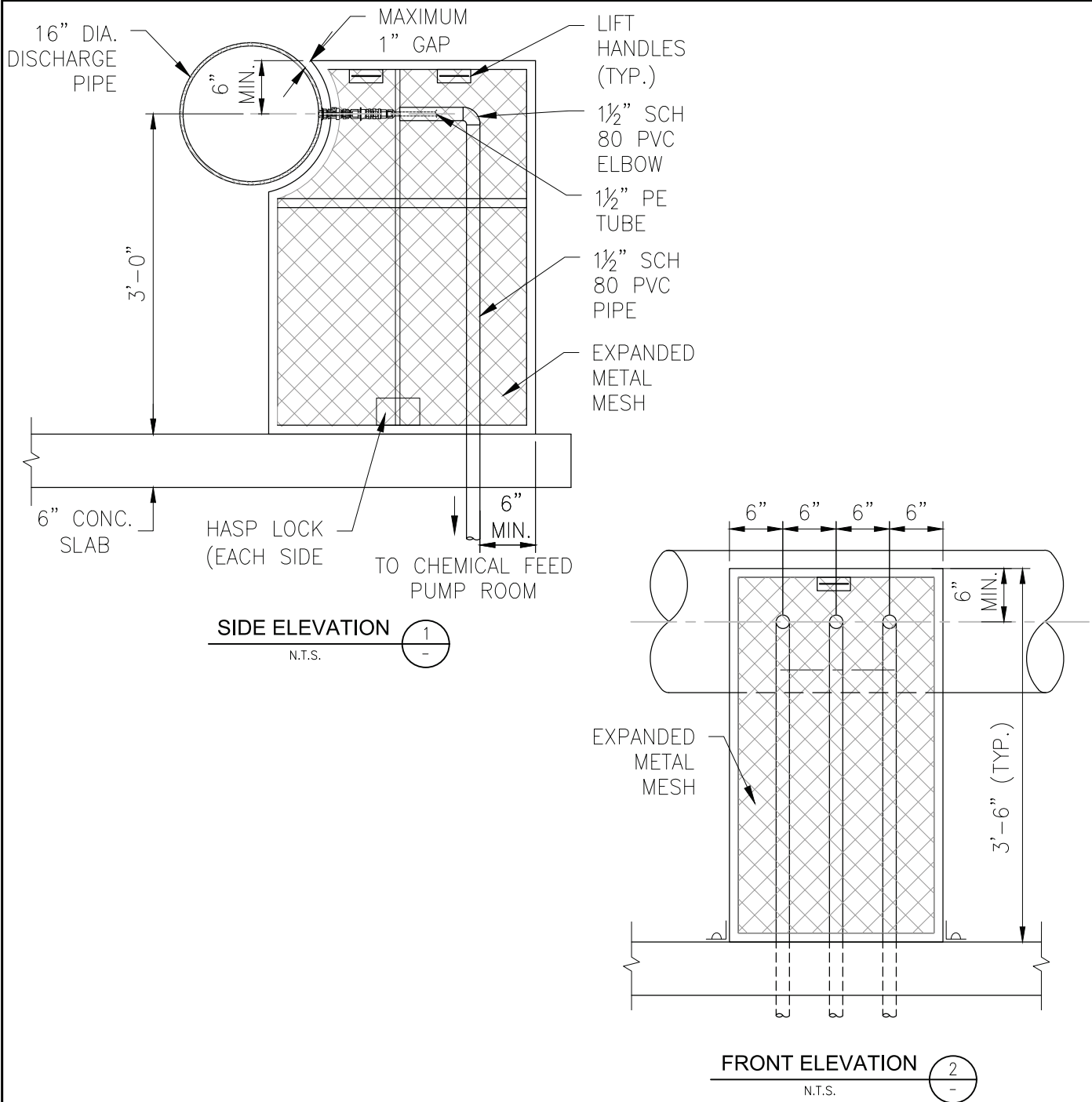

NOTES:

1. Protective cage to be constructed of formed steel angle frame and expanded metal mesh welded together.
2. Protect steel from corrosion with a high grade powder coated finish similar in color to adjacent pipe.
3. Provide lifting handles and hasp-type lock system.
4. Cage configuration to be modified to match structure or pipe where it will be constructed.
5. Cage width is dependant on number of injectors attached to the pipe.
6. See standard drawing W-8 for injection quill details.

APPROVED BY: GSWC STANDARDS COMMITTEE  EDC MANAGER	 Golden State Water Company <small>A Subsidiary of American States Water Company</small>	TITLE: INJECTION POINT / SAMPLE PORT PROTECTIVE CAGE			
6/15/26 DATE		SCALE: NONE	DATE: 07/31/23	REV 2024	STANDARD DWG NO. C-18

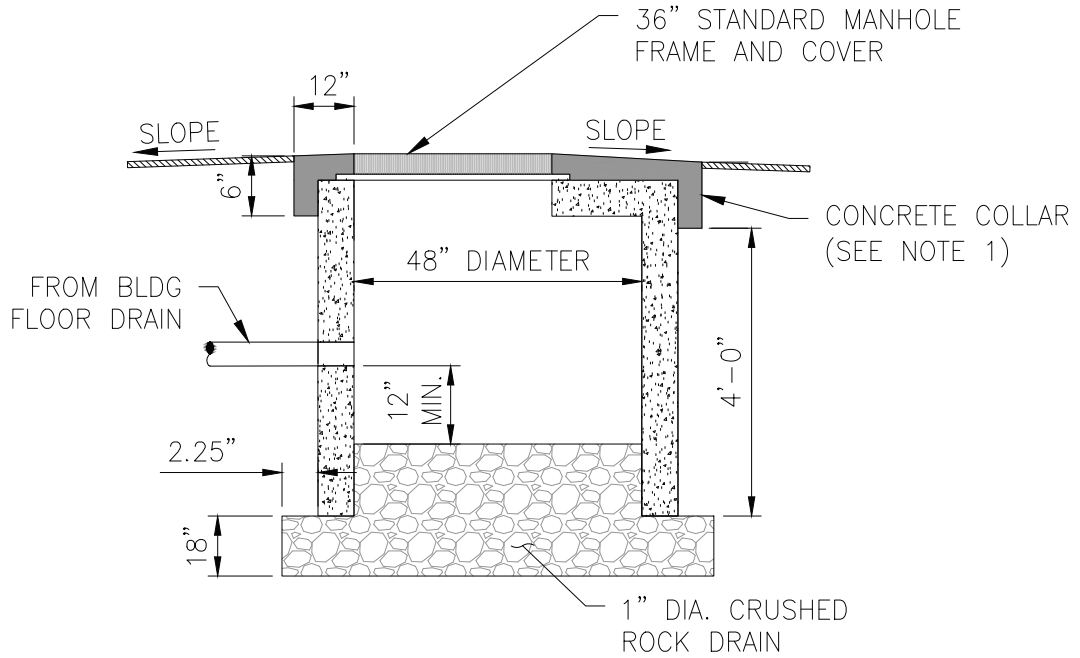

SECTION A
N.T.S.

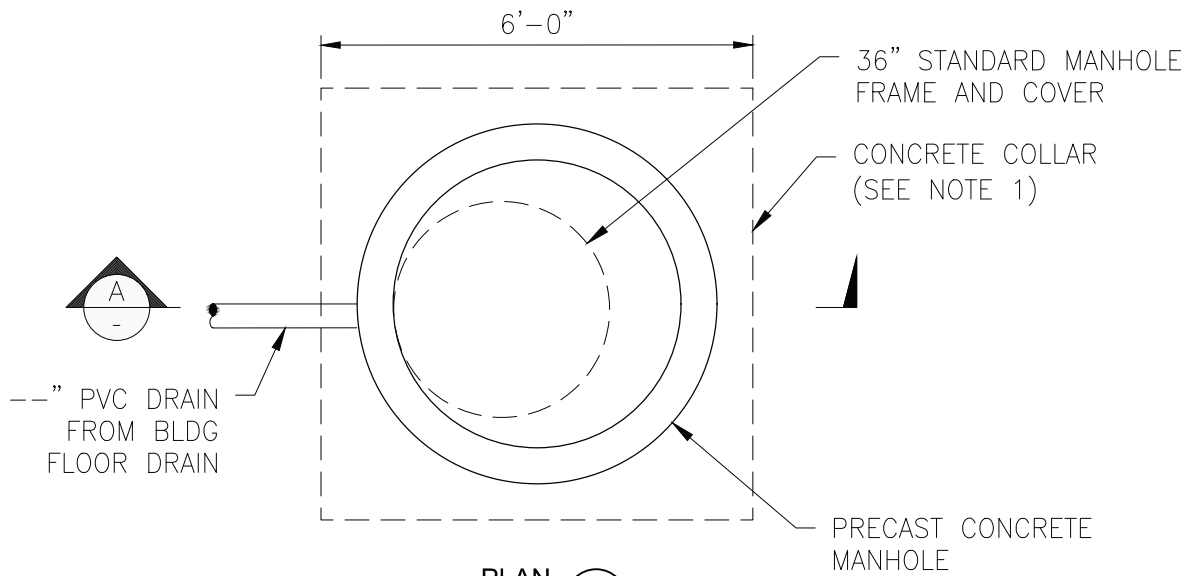

PLAN 1
N.T.S.

NOTES:

1. In unpaved traffic areas, install a 6-ft square concrete collar (6-in thick) as shown in plan view.
2. In paved areas, manhole frame and cover shall be flush with finished surface.

APPROVED BY:
GSWC STANDARDS COMMITTEE

Alison Sweet

EDC MANAGER

6/15/26
DATE



Golden State
Water Company

A Subsidiary of American States Water Company

TITLE:

LOCAL DRAINAGE STRUCTURE

SCALE:
NONE

DATE:
01/06/26

REV
2026

STANDARD DWG NO.
C-19A

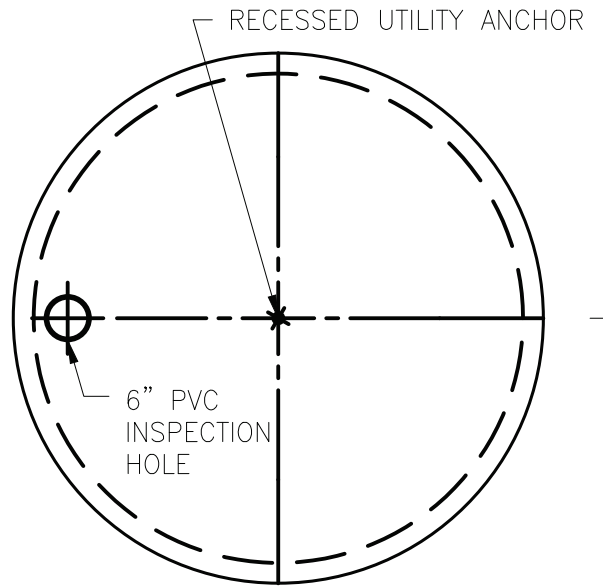
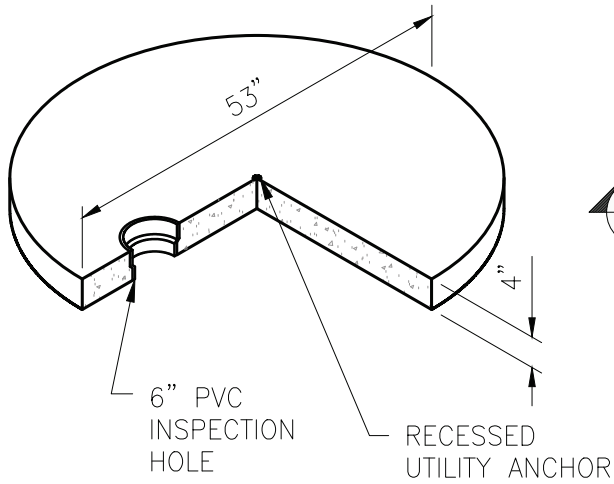

PLAN 1
N.T.S. -

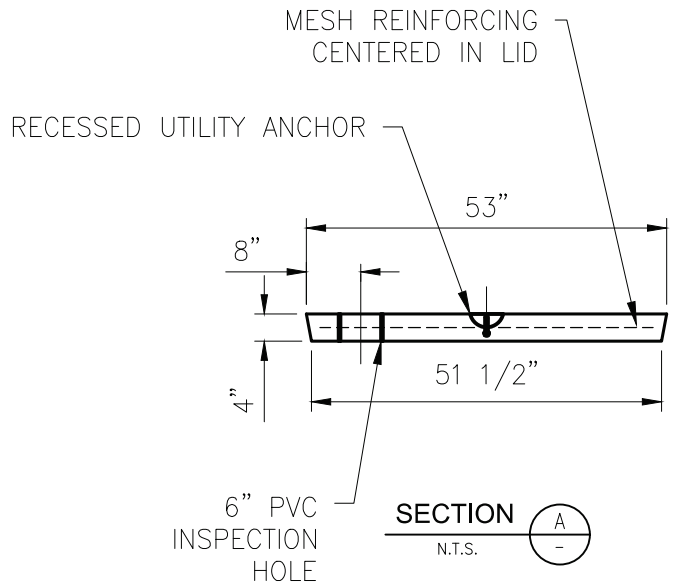
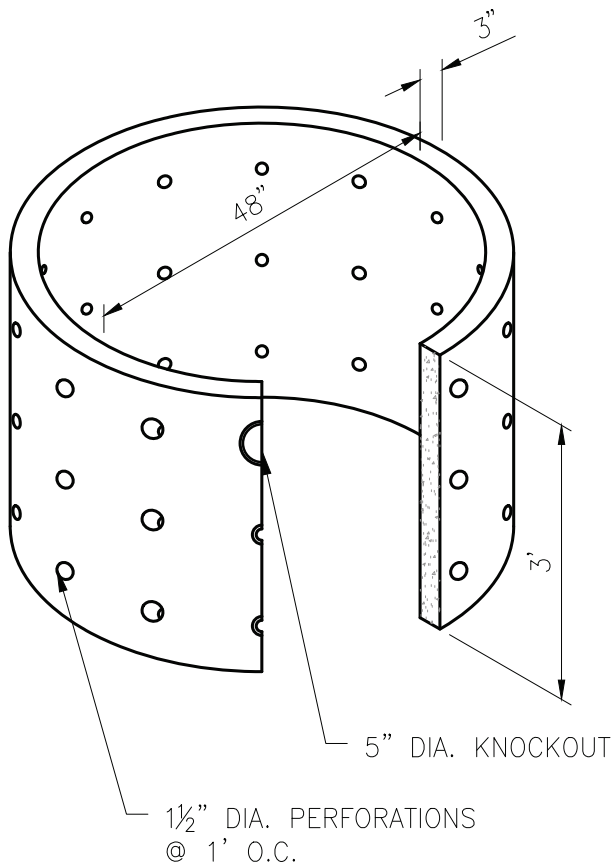

APPROVED BY:
GSWC STANDARDS COMMITTEE

Alison Sweet

EDC MANAGER

6/15/26
DATE



Golden State
Water Company

A Subsidiary of American States Water Company

TITLE:

LOCAL DRAINAGE PIT
& LID STACK ASSEMBLY

SCALE:
NONE

DATE:
01/06/26

REV
2026

STANDARD DWG NO.
C-19B

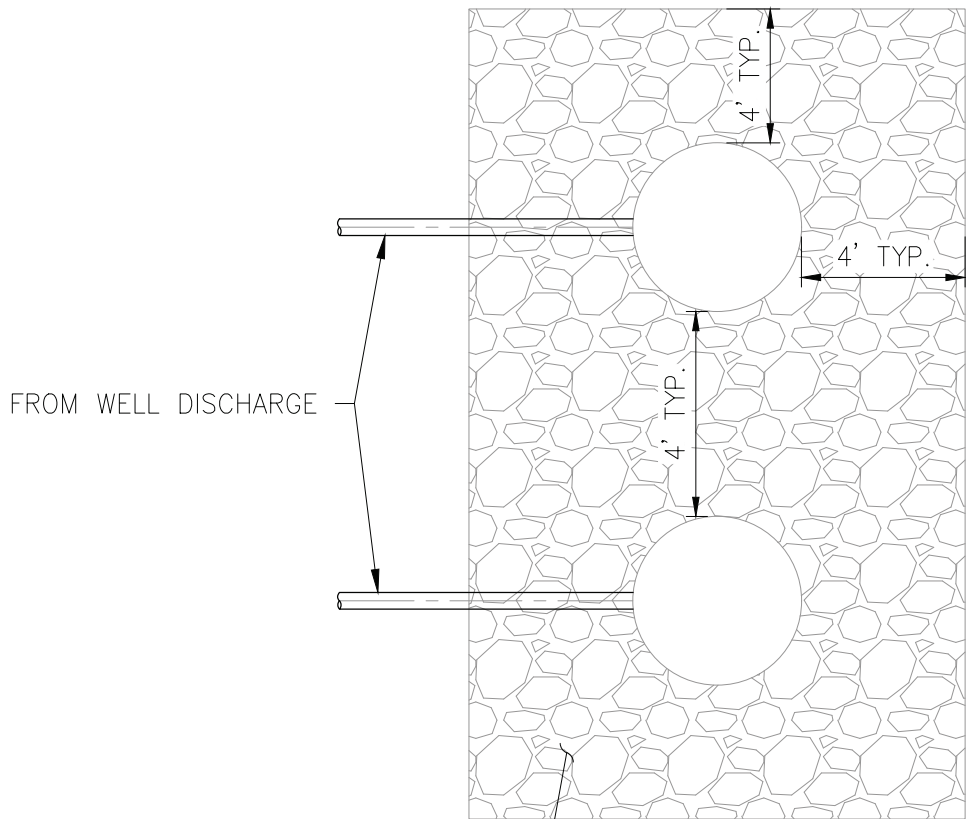

3/4" CRUSHED ROCK

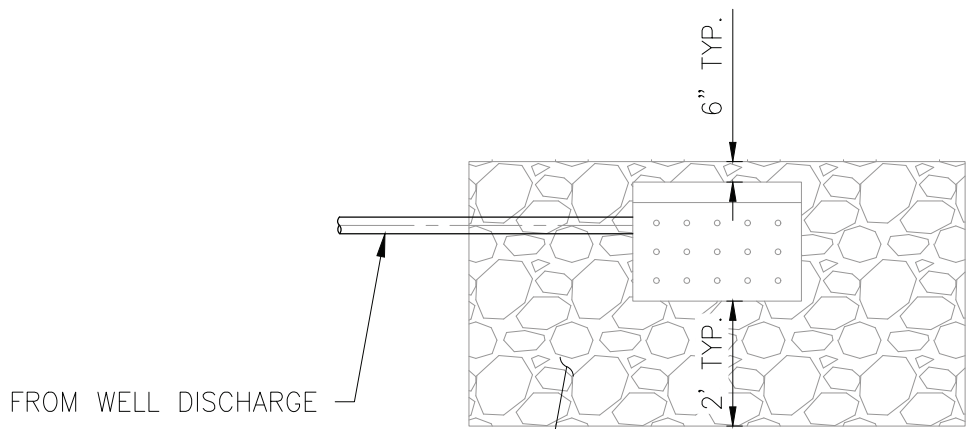

3/4" CRUSHED ROCK

APPROVED BY:
GSWC STANDARDS COMMITTEE

Alison Sweet

EDC MANAGER

6/15/26
DATE



Golden State
Water Company

A Subsidiary of American States Water Company

TITLE:

LOCAL DRAINAGE PIT
TYPICAL SEEPAGE PIT PLAN

SCALE:
NONE

DATE:
01/30/26

REV
2026

STANDARD DWG NO.
C-19C

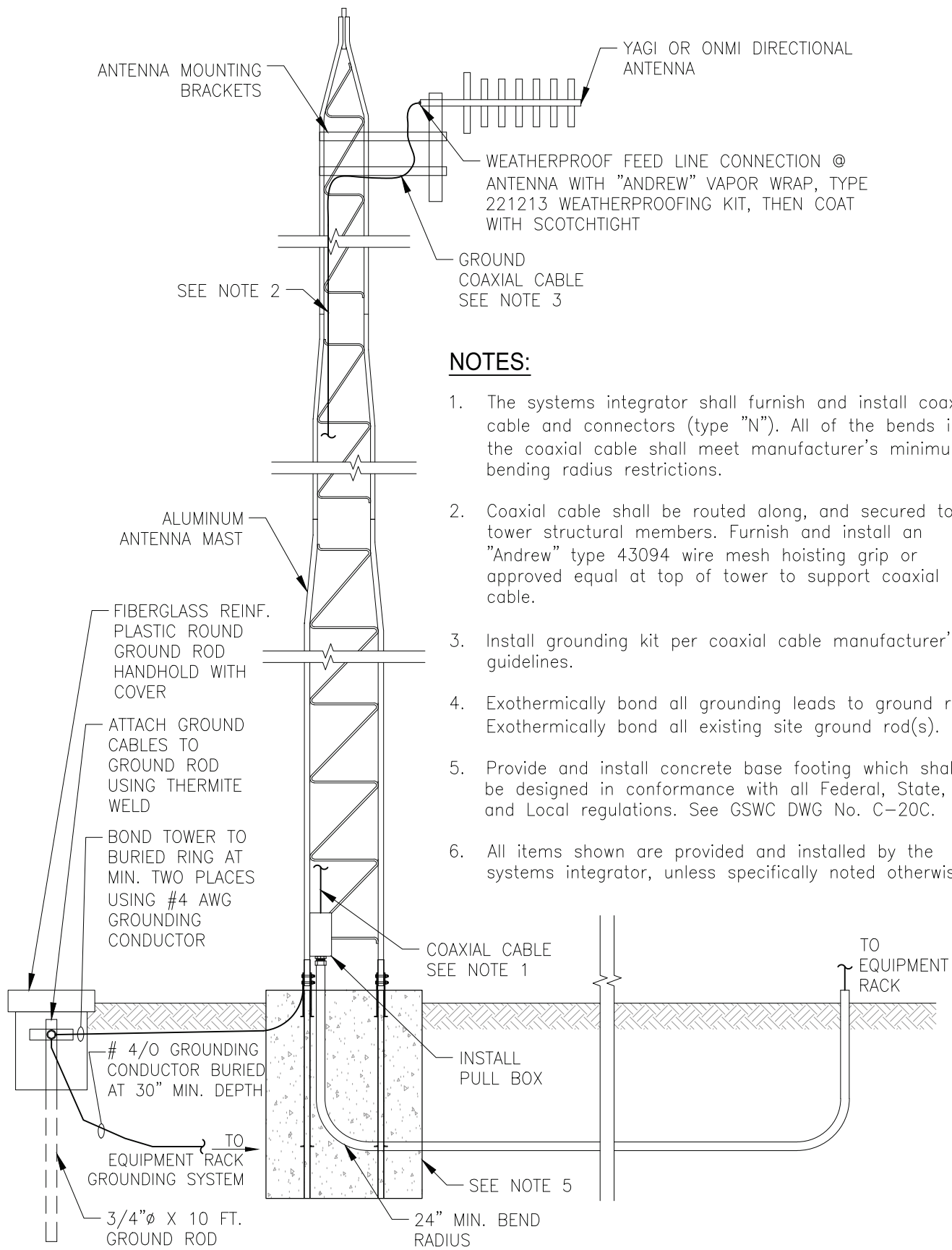

NOTES:

1. The systems integrator shall furnish and install coaxial cable and connectors (type "N"). All of the bends in the coaxial cable shall meet manufacturer's minimum bending radius restrictions.
2. Coaxial cable shall be routed along, and secured to tower structural members. Furnish and install an "Andrew" type 43094 wire mesh hoisting grip or approved equal at top of tower to support coaxial cable.
3. Install grounding kit per coaxial cable manufacturer's guidelines.
4. Exothermically bond all grounding leads to ground ring. Exothermically bond all existing site ground rod(s).
5. Provide and install concrete base footing which shall be designed in conformance with all Federal, State, and Local regulations. See GSWC DWG No. C-20C.
6. All items shown are provided and installed by the systems integrator, unless specifically noted otherwise.

APPROVED BY:
GSWC STANDARDS COMMITTEE

Alison Sweet

EDC MANAGER

6/15/26
DATE



Golden State
Water Company

A Subsidiary of American States Water Company

TITLE:
ALUMINUM TOWER
ANTENNA AND GROUNDING

SCALE: NONE	DATE: 07/31/23	REV 2024	STANDARD DWG NO. C-20A
----------------	-------------------	-------------	---------------------------

**COUNTERBALANCED ANTENNA POLE
STYLE PT-P**

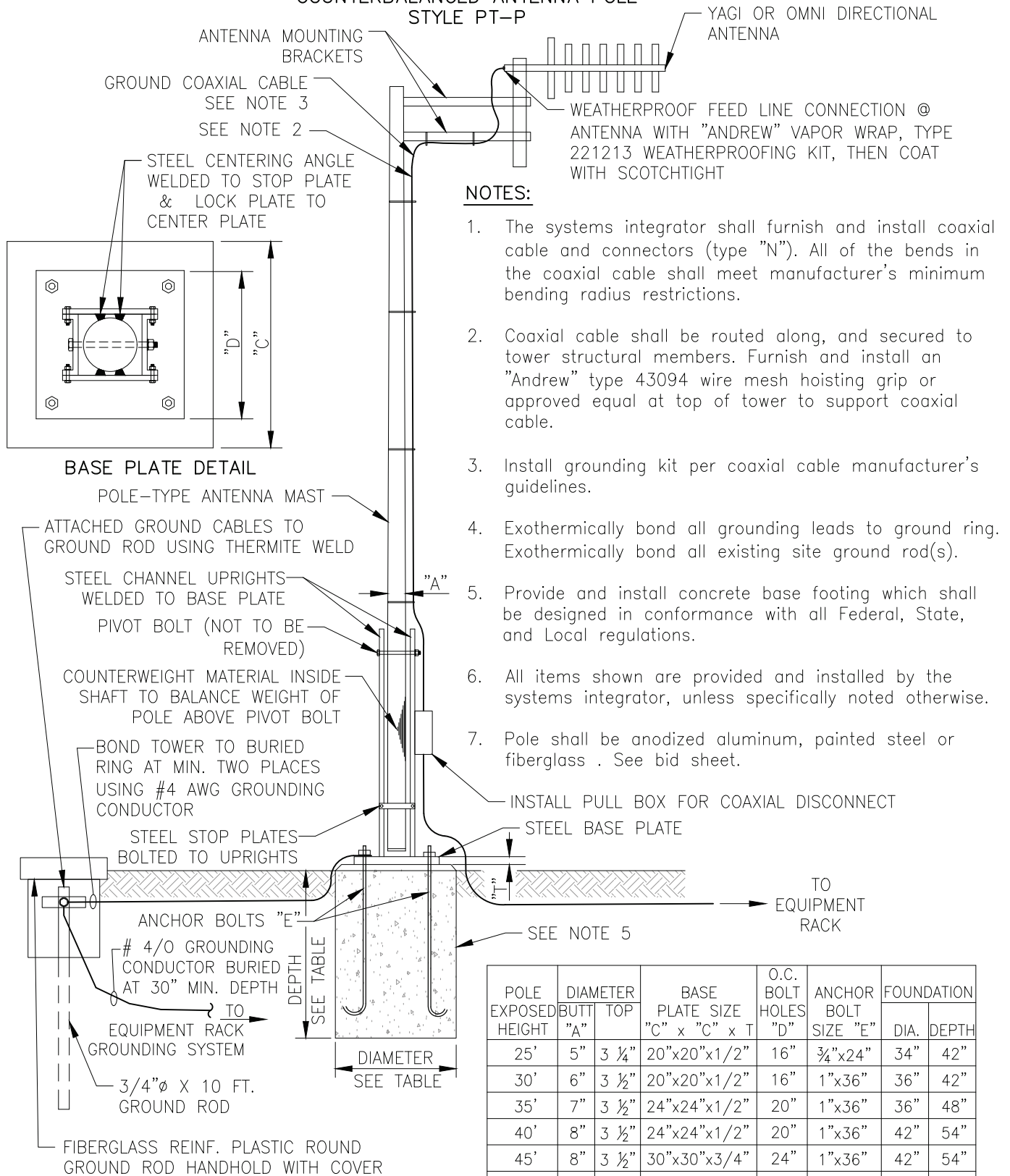

APPROVED BY:
GSWC STANDARDS COMMITTEE

Alison Sweet

EDC MANAGER

6/15/26
DATE



Golden State
Water Company

A Subsidiary of American States Water Company

TITLE:

**SCADA ANTENNA POLE
AND GROUNDING**

SCALE:
NONE

DATE:
07/31/23

REV
2024

STANDARD DWG NO.
C-20B

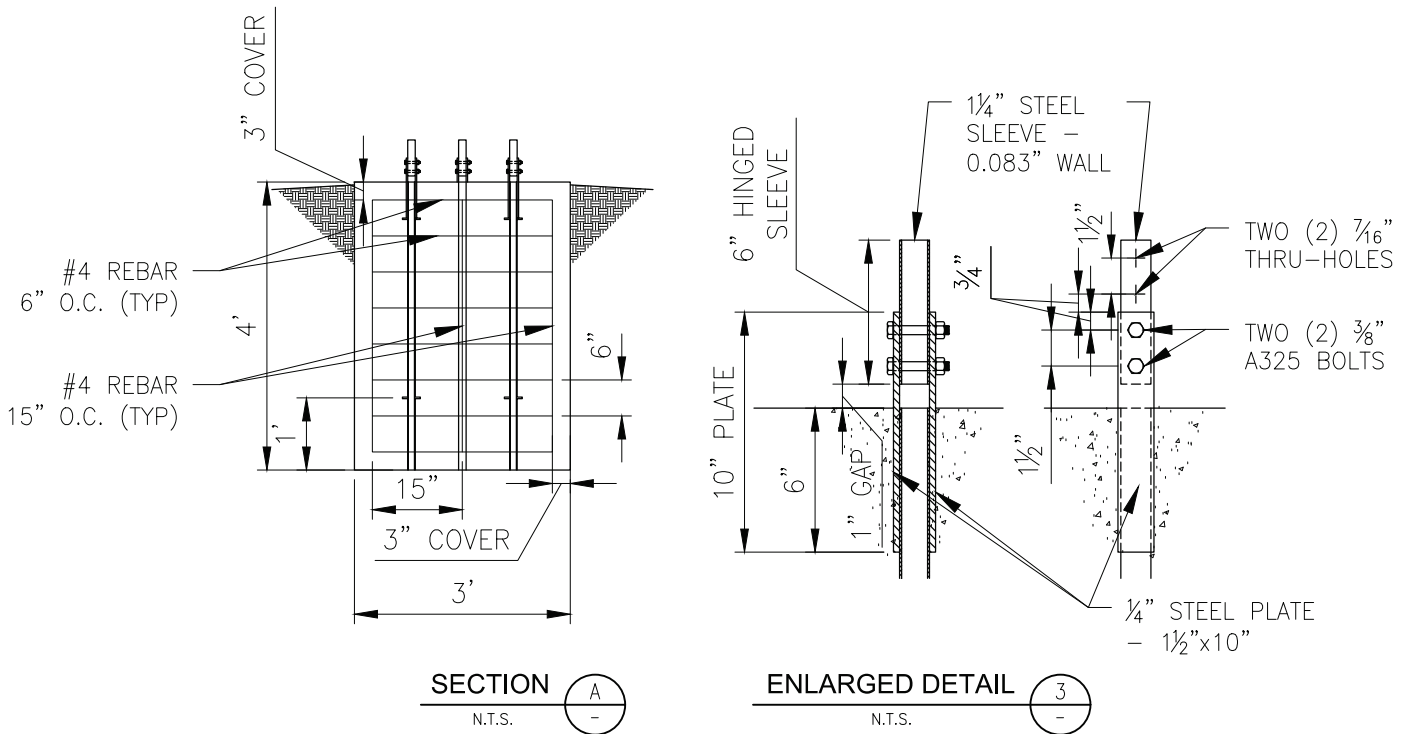
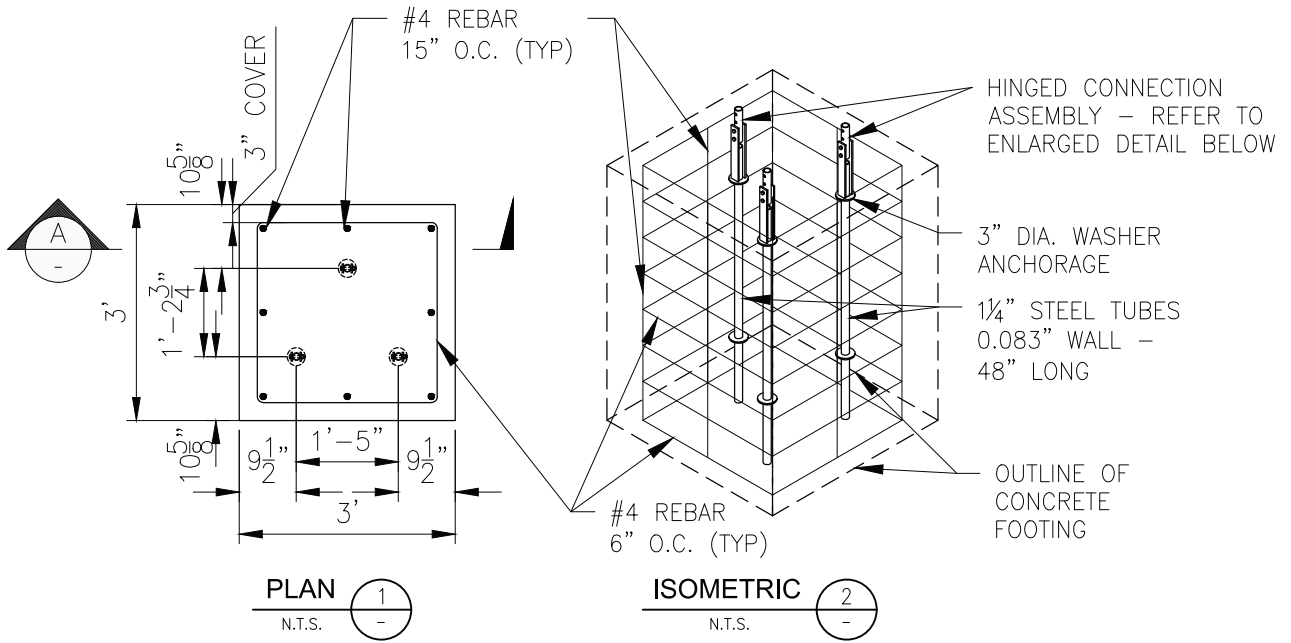

NOTES:

1. Provide and install concrete base footing which shall be designed in conformance with all Federal, State, and Local regulations. Base footing dimensions to change based on tower manufacturer recommendation.

APPROVED BY:
GSWC STANDARDS COMMITTEE

Alison Sweet

EDC MANAGER

6/15/26
DATE



Golden State
Water Company

A Subsidiary of American States Water Company

TITLE:

ALUMINUM TOWER
BASE FOOTING DETAIL

SCALE:
NONE

DATE:
12/19/25

REV
2026

STANDARD DWG NO.
C-20C

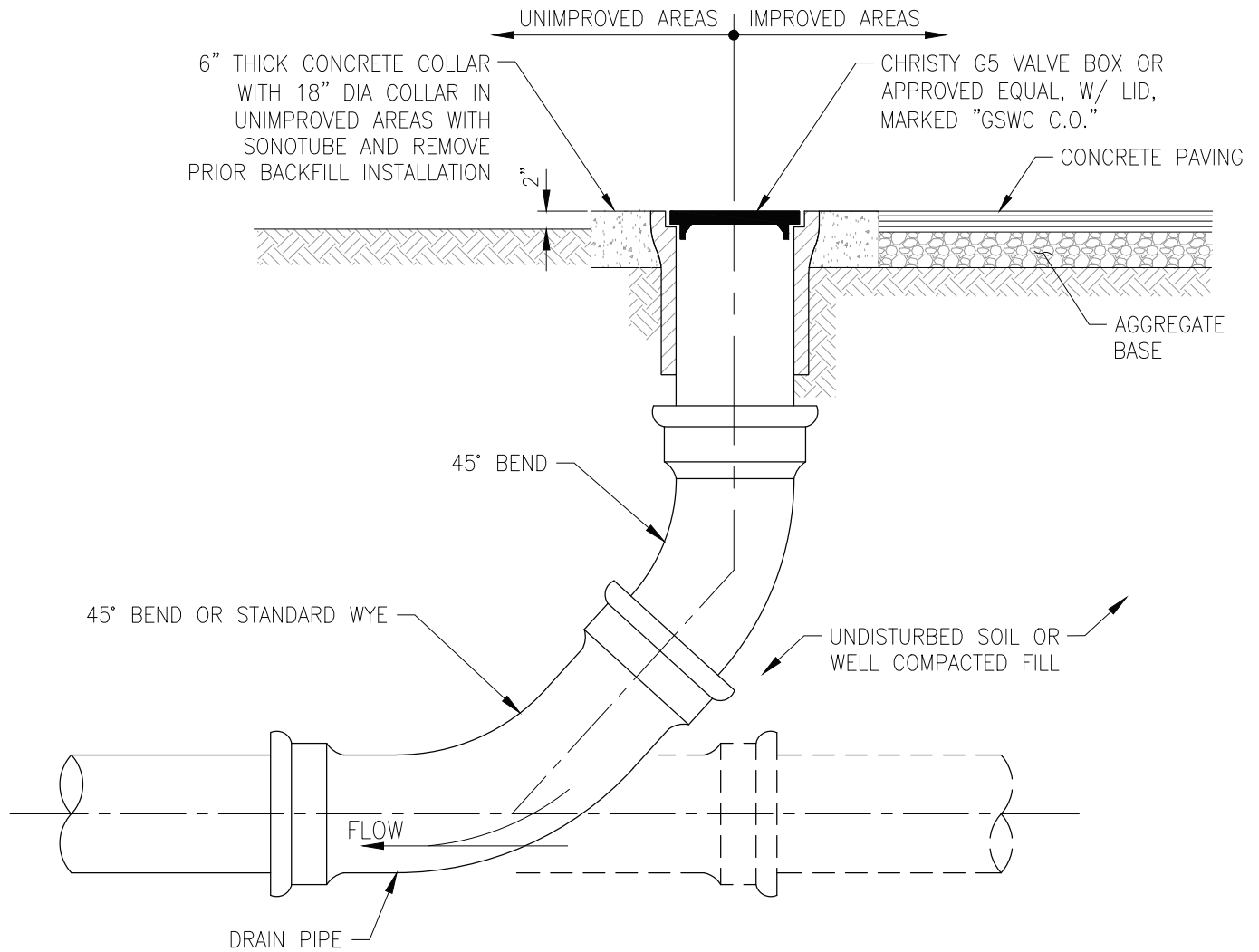

1. THE FOLLOWING VALVE BOX TYPES SHALL BE USED UNLESS OTHERWISE NOTED:
 - TYPE 1 – UNIMPROVED AREAS, CONCRETE SURFACED STREETS, CONCRETE PADS, OR AS CALLED OUT ON THE PLANS.
 - TYPE 3 – ALL OTHER LOCATIONS AS CALLED OUT ON THE PLANS. (SEE STANDARD DRAWINGS P-31 & P-32 FOR EXAMPLES OF VALVE BOX TYPES)
2. FINAL RIM ELEVATION TO BE $\frac{1}{8}$ " TO $\frac{1}{4}$ " BELOW FINAL STREET GRADE.
3. MORE STRINGENT INSTALLATION REQUIREMENTS MAY BE IMPOSED BY THE ENTITY HAVING THE JURISDICTION OVER THE VALVE BOX INSTALLATION LOCATION.
6. SEE POTABLE WATER MATERIALS GUIDELINES FOR ALL APPROVED PRODUCTS.
7. CONTRACTOR TO FORM 18 INCH DIAMETER CONCRETE COLLAR IN UNIMPROVED AREAS WITH SONOTUBE AND REMOVE PRIOR TO BACKFILL INSTALLATION (TYP).

APPROVED BY:
GSWC STANDARDS COMMITTEE

Alison Sweet

EDC MANAGER

6/15/26
DATE



Golden State
Water Company

A Subsidiary of American States Water Company

TITLE:

**DRAIN PIPE
CLEAN-OUT DETAIL**

SCALE:	DATE:	REV	STANDARD DWG NO.
NONE	07/31/23	2024	C-21

Part B – Facility Design Drawings

Section 3
Pump Stations

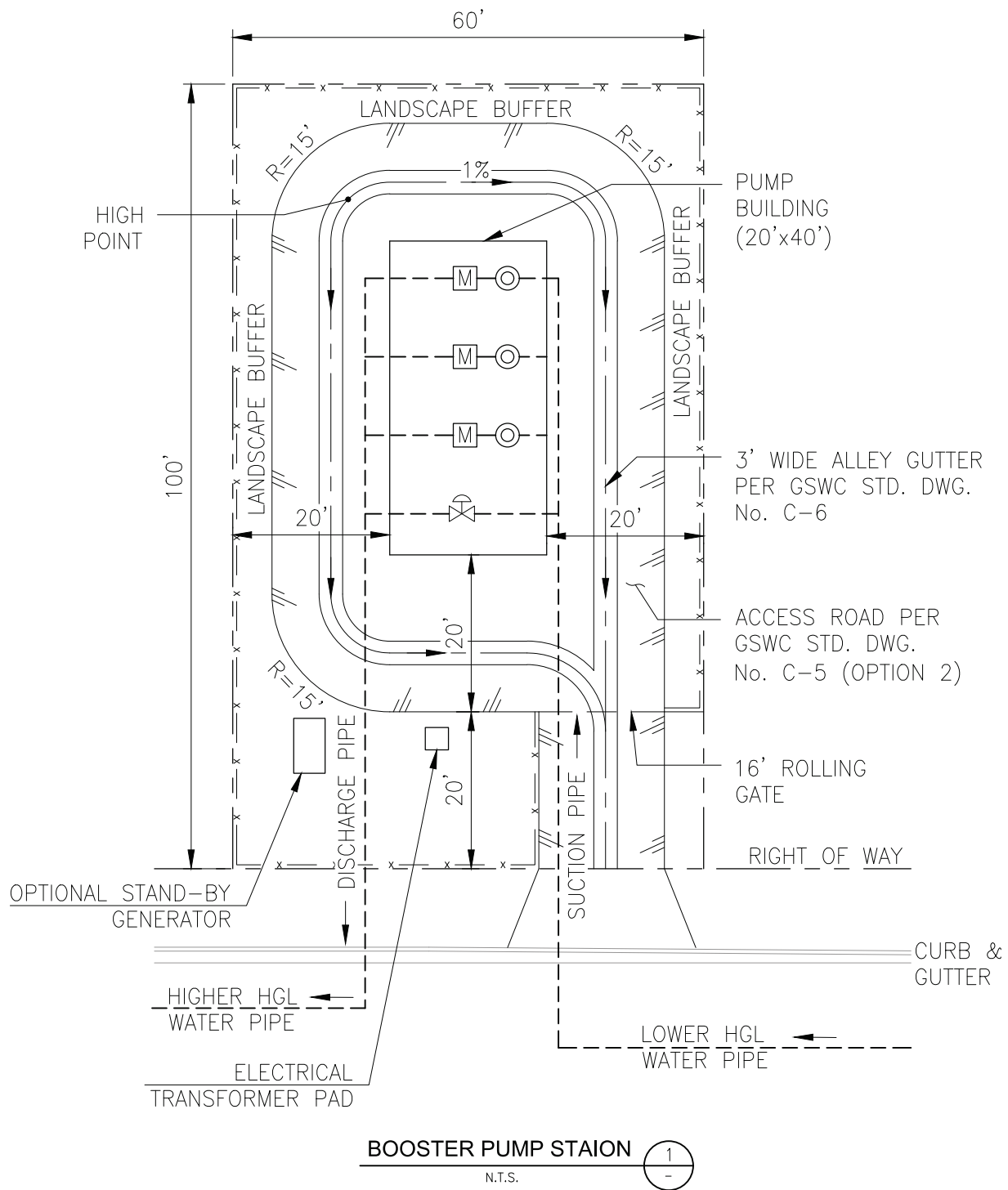

NOTES:

1. Dimensions, locations, and drainage shall be modified for each specific project.
2. Lot should drain to the street. Adjust lot elevations as needed.
3. Pump station size will vary based on the number of pumps. Generally each additional pump adds 10' of length. See GSWC STD. DWG. No. PS-2A for additional details.

APPROVED BY:
GSWC STANDARDS COMMITTEE

Alison Sweet

EDC MANAGER

6/15/26
DATE



Golden State
Water Company

A Subsidiary of American States Water Company

TITLE:

TYPICAL BOOSTER PUMP STATION
SITE PLAN AND DIMENSIONS

SCALE:	DATE:	REV	STANDARD DWG NO.
NONE	04/02/26	2026	PS-1

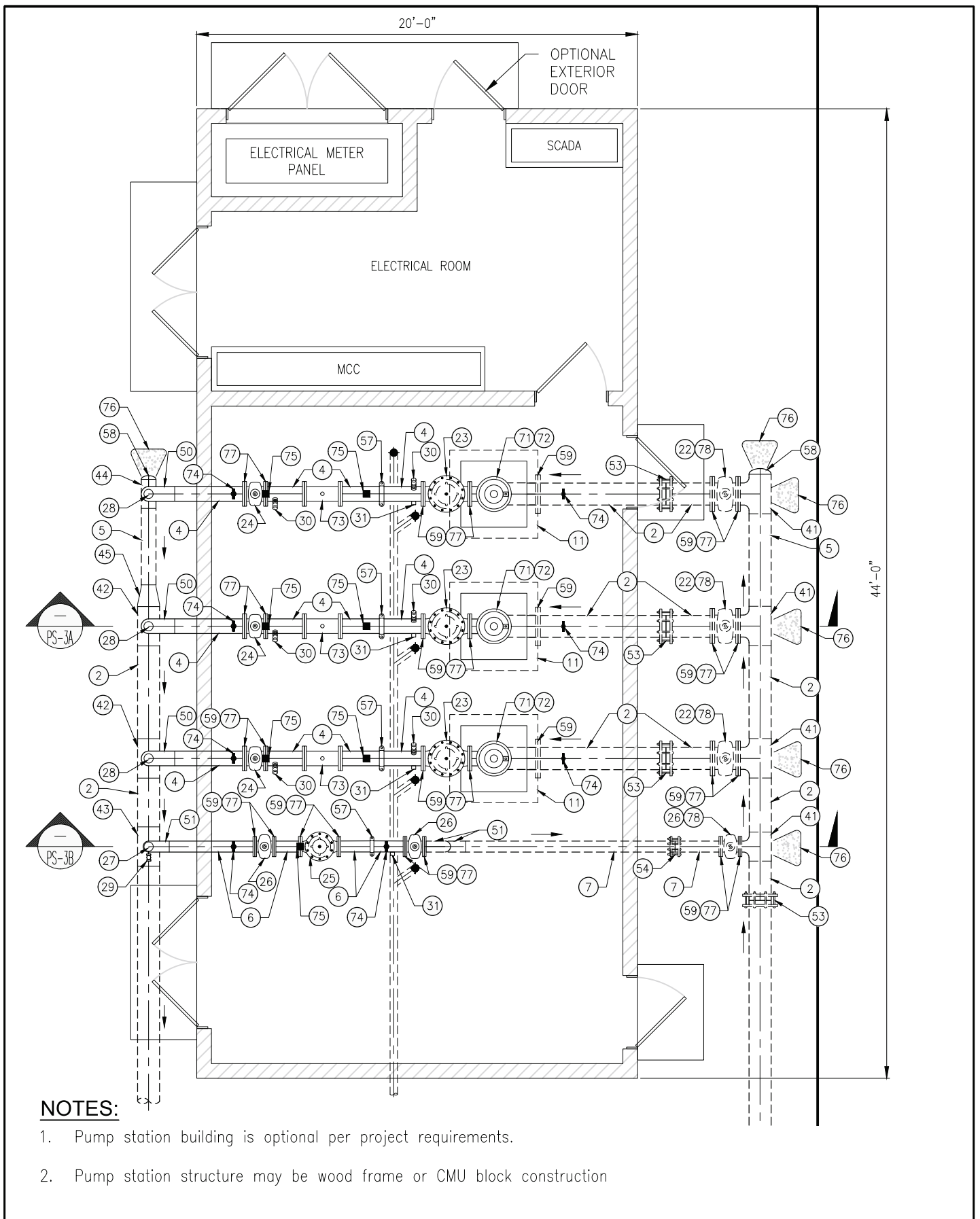

NOTES:

1. Pump station building is optional per project requirements.
2. Pump station structure may be wood frame or CMU block construction

APPROVED BY:
GSWC STANDARDS COMMITTEE

Alison Sweet

EDC MANAGER

6/15/26
DATE



Golden State
Water Company

A Subsidiary of American States Water Company

TITLE:
STANDARD PUMP STATION FLOOR PLAN
AND PIPING PLAN

SCALE:	DATE:	REV	STANDARD DWG NO.
NONE	04/02/26	2026	PS-2A

CONSTRUCTION NOTES

PIPE

- ①— INSTALL 12" STEEL PIPE, EPOXY LINED AND PAINTED.
- ②— INSTALL 12" STEEL PIPE, EPOXY LINED AND MORTAR COATED, PER GSWC SPECIFICATIONS
- ③— INSTALL 12" CLASS 350 DUCTILE IRON OR PVC PIPE PER GSWC SPECIFICATIONS
- ④— INSTALL 8" STEEL PIPE, EPOXY LINED AND PAINTED.
- ⑤— INSTALL 8" STEEL PIPE, EPOXY LINED AND MORTAR COATED, PER GSWC SPECIFICATIONS
- ⑥— INSTALL 6" STEEL PIPE, EPOXY LINED AND PAINTED.
- ⑦— INSTALL 6" STEEL PIPE, EPOXY LINED AND MORTAR COATED, PER GSWC SPECIFICATIONS
- ⑧— INSTALL 4" PVC DRAIN PIPE AND FITTINGS, SCH 80

MISCELLANEOUS

- ⑪— 4'x4' SKYLIGHT OPENING THROUGH ROOF
- ⑫— INSTALL 6" FLOOR DRAIN, SMITH FIGURE 2505

VALVES

- ⑰— INSTALL 12" BUTTERFLY VALVE (CL-250), (FE) WITH HANDWHEEL
- ⑱— INSTALL 12" RW GATE VALVE (CL-250), (FE)
- ⑲— INSTALL 8" CHECK VALVE (CLA-VAL MODEL 81-02)
- ⑳— INSTALL 8" RW GATE VALVE (CL-250), (FE)
- ㉑— INSTALL 6" PRESSURE RELIEF AND PRESSURE SUSTAINING VALVE (CLA-VAL MODEL 50-01 WITH XP2F-X35 PACKAGE)
- ㉒— INSTALL 6" RW GATE VALVE (CL-250), (FE)
- ㉓— INSTALL 2" COMBINATION AIR RELEASE AND VACUUM VALVE ASSEMBLY.
- ㉔— INSTALL 1" COMBINATION AIR RELEASE AND VACUUM VALVE ASSEMBLY.
- ㉕— INSTALL 1" THREAD-O-LET AND 1"x 3/4" DIELECTRIC BUSHING WITH A 3/4" HOSE BIBB AND HOSE BIBB VACUUM BREAKER (HBVB)
- ㉖— INSTALL WELD-ON 1" THREAD-O-LET, 1" CORPORATION STOP WITH 1" BRASS PLUG FOR METER TEST. SET AT 45° DOWN FROM TOP OF PIPE
- ㉗— INSTALL 1" THREAD-O-LET AND 1" CORP STOP ORIENTED AT 3 O-CLOCK POSITION

FITTINGS

- ④①— INSTALL 12"x12"x12" STEEL TEE
- ④②— INSTALL 12"x12"x8" STEEL TEE
- ④③— INSTALL 12"x12"x6" STEEL TEE
- ④④— INSTALL 8"x8"x8" STEEL TEE
- ④⑤— INSTALL 12"x8" STEEL REDUCER (PE)
- ④⑥— INSTALL 12" 90° DUCTILE IRON ELBOW (MJxFE)
- ④⑦— INSTALL 12" 90° STEEL ELBOW, LR (PE)
- ④⑧— INSTALL 12" 90° STEEL ELBOW, LR (FE)
- ④⑨— INSTALL 12" 90° STEEL ELBOW, SR (PE)
- ⑤①— INSTALL 8" 90° STEEL ELBOW, LR (PE)
- ⑤②— INSTALL 6" 90° STEEL ELBOW, LR (PE)
- ⑤③— INSTALL 12" DRESSER STYLE FLEXIBLE COUPLING
- ⑤④— INSTALL 6" DRESSER STYLE FLEXIBLE COUPLING
- ⑤⑤— INSTALL 12" VICTAULIC COUPLING, STYLE 77
- ⑤⑥— INSTALL 8" VICTAULIC COUPLING, STYLE 77
- ⑤⑦— INSTALL 6" VICTAULIC COUPLING, STYLE 77
- ⑤⑧— INSTALL 8" WELD-ON DISHED HEAD CAP
- ⑤⑨— INSTALL PIPE SIZE WELD-ON FLANGE
- ⑥①— INSTALL 12" STLxDI TRANSITION COUPLING

SPECIALS

- ⑦①— INSTALL PUMP MOTOR PER SPECIFICATIONS
- ⑦②— INSTALL PUMP PER SPECIFICATIONS
- ⑦③— INSTALL 8" MAGMETER
- ⑦④— INSTALL TAP FOR PRESSURE GAUGE & PRESSURE TRANSMITTER
- ⑦⑤— INSTALL ADJUSTABLE PIPE SUPPORT
- ⑦⑥— INSTALL THRUST BLOCK
- ⑦⑦— INSTALL FLANGE CONNECTION BETWEEN STEEL AND DIP WITH AN INSULATING GASKET
- ⑦⑧— INSTALL VALVE CAN

NOTES:

1. All above ground steel pipe and fittings shall be epoxy lined and painted per the specifications.
2. All underground steel piping and fittings shall be epoxy lined and cement mortar coated. Coating shall terminate at 4 inches above grade.
3. All epoxy coating damaged by welding or field installation shall be repaired per the specifications.
4. Flanged connections between ductile iron pipe and valves and steel pipe shall include an insulating gasket to electrically isolate each metal surface from the other. Insulating gasket shall be per specifications.
5. Above ground valves will be supplied with handwheels unless permanent location is outside of pump building.
6. All buried ductile iron pipe, fittings, and valves shall be encased with 8 mil thick polyethylene encasement which shall be in accordance with the manufacturer's recommendations and AWWA Standard C105.
7. All buried portions of pipe shall be installed per GSWC specifications and specified trench details.
8. All buried flexible and mechanical joint pipe connections shall be fully restrained.
9. Pipe diameters are subject to change from the sizes listed per pump design criteria

APPROVED BY:
GSWC STANDARDS COMMITTEE

Alison Sweet

EDC MANAGER

6/15/26
DATE



Golden State
Water Company

A Subsidiary of American States Water Company

TITLE:

STANDARD PUMP STATION FLOOR PLAN
AND PIPING PLAN

SCALE:	DATE:	REV	STANDARD DWG NO.
NONE	04/02/26	2026	PS-2B

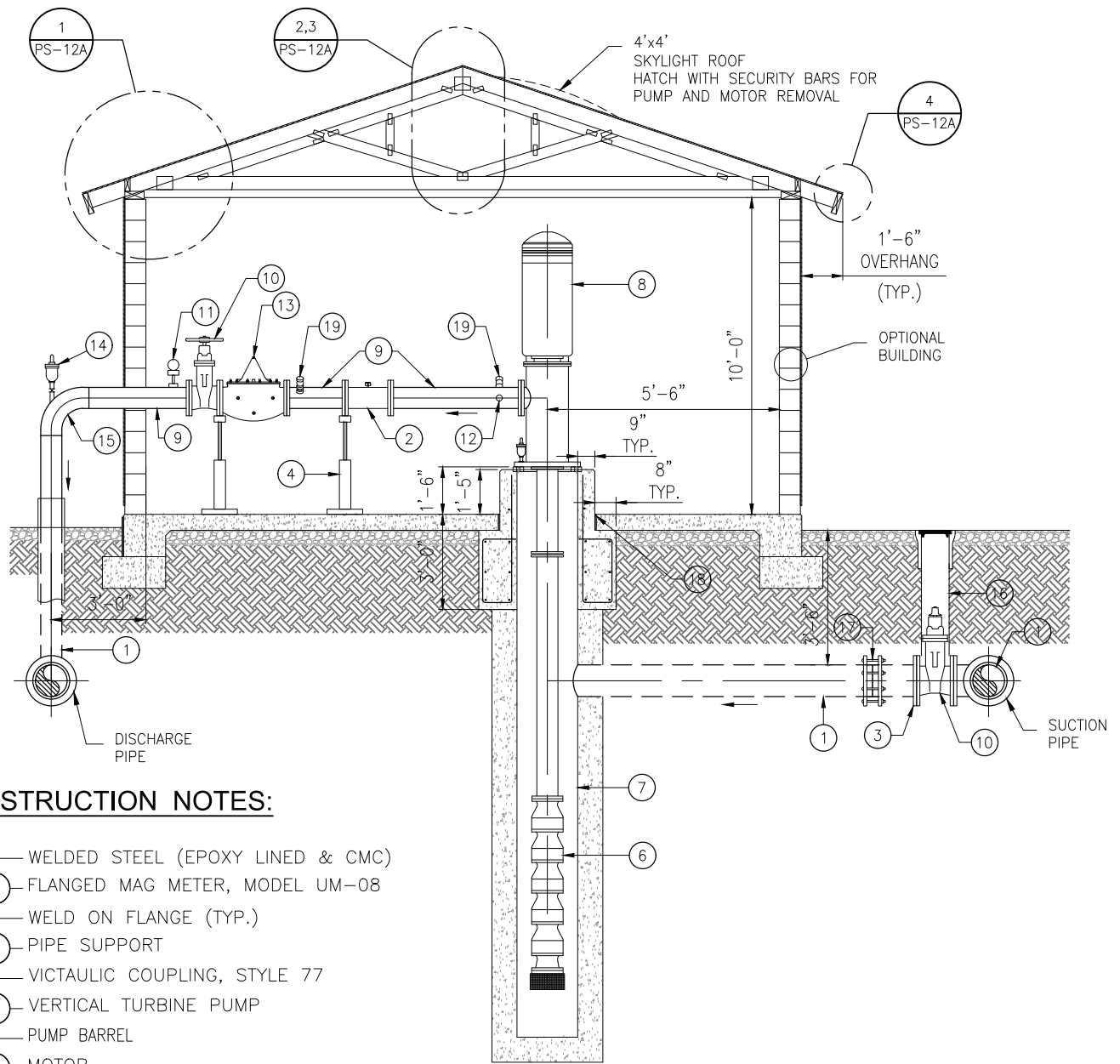

CONSTRUCTION NOTES:

- ① — WELDED STEEL (EPOXY LINED & CMC)
- ② — FLANGED MAG METER, MODEL UM-08
- ③ — WELD ON FLANGE (TYP.)
- ④ — PIPE SUPPORT
- ⑤ — VICTAULIC COUPLING, STYLE 77
- ⑥ — VERTICAL TURBINE PUMP
- ⑦ — PUMP BARREL
- ⑧ — MOTOR
- ⑨ — WELDED STEEL PIPE, EPOXY LINED AND PAINTED
- ⑩ — FLANGED RW GATE VALVE (CL150)
- ⑪ — PRESSURE SWITCH WITH READOUT GAUGE
- ⑫ — 1" CORP STOP AND 1" SERVICE SADDLE ORIENTED AT 3 O'CLOCK POSITION
- ⑬ — FLANGED CHECK VALVE. CLA-VAL MODEL 81-02
- ⑭ — AIR RELEASE AND VACUUM VALVE ASSEMBLY
- ⑮ — WELDED STEEL 90° LONG RADIUS (EPOXY LINED)
- ⑯ — VALVE BOX PER GSWC STD. DWG. P-44 OR P-45
- ⑰ — FLEXIBLE COUPLING
- ⑱ — RTV SILICONE SEALANT
- ⑲ — THREAD-O-LET FOR METER TEST

APPROVED BY:
GSWC STANDARDS COMMITTEE

Alison Sweet

EDC MANAGER

6/15/26
DATE



Golden State
Water Company

A Subsidiary of American States Water Company

TITLE:

TYPICAL PUMP STATION
PUMP AND PIPING SECTION

SCALE:	DATE:	REV	STANDARD DWG NO.
NONE	03/31/26	2026	PS-3A

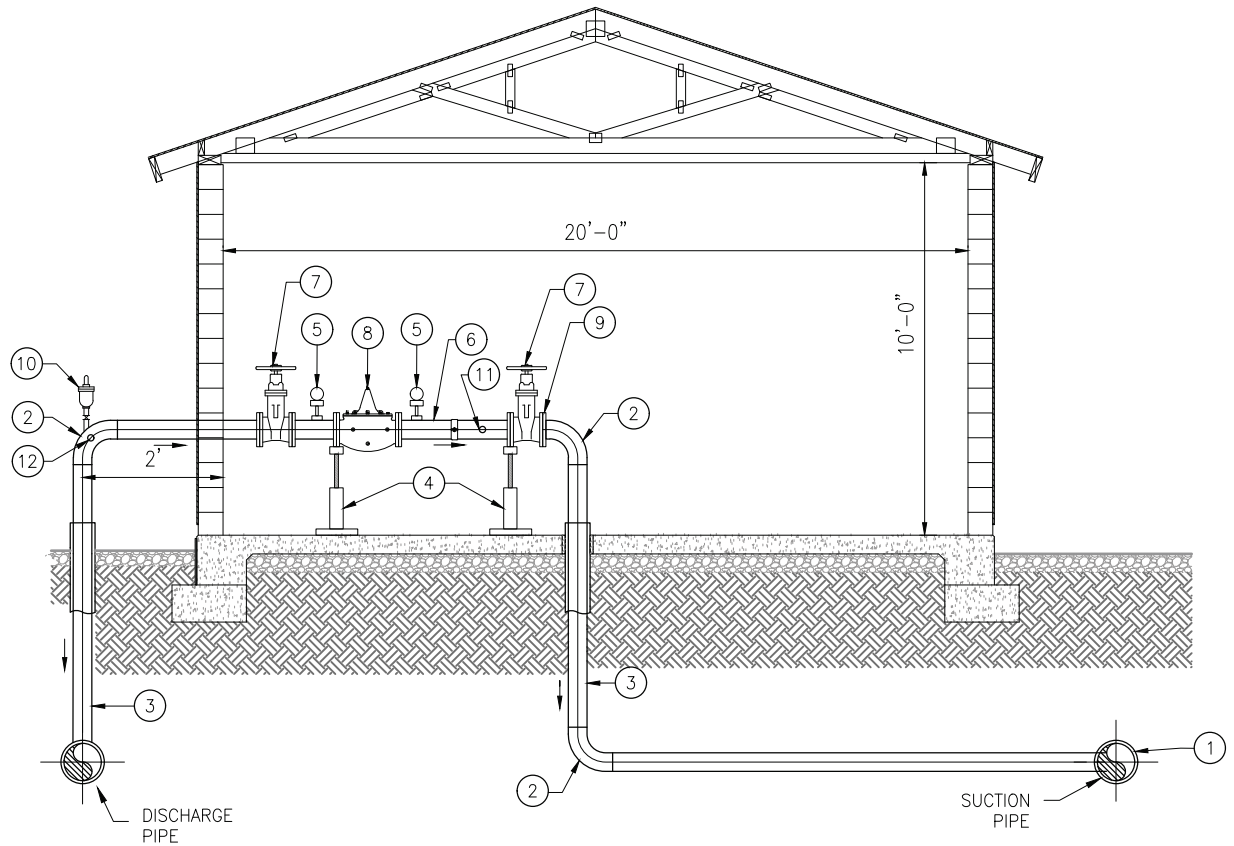

CONSTRUCTION NOTES:

- ① — WELDED STEEL TEE (EPOXY LINED & CMC)
- ② — WELDED STEEL 90° ELBOW, LONG RADIUS (EPOXY LINED)
- ③ — WELDED STEEL (EPOXY LINED & CMC)
- ④ — PIPE SUPPORT
- ⑤ — PRESSURE GAUGE AND TRANSDUCER
- ⑥ — VICTAULIC COUPLING, STYLE 77
- ⑦ — FLANGED RW GATE VALVE (CL150)
- ⑧ — FLANGED PRESSURE RELIEF AND PRESSURE SUSTAINING VALVE, CLA-VAL MODEL 50-01 WITH XP2F-X35 PACKAGE
- ⑨ — WELD-ON FLANGE
- ⑩ — AIR RELEASE AND VACUUM VALVE ASSEMBLY
- ⑪ — INSTALL 1" THREAD-0-LET AND 1" CORP STOP ORIENTED AT 3 O-CLOCK POSITION
- ⑫ — INSTALL 1" THREAD-0-LET AND 1"x¾" DIELECTRIC BUSHING WITH A ¾" HOSE BIBB

APPROVED BY:
GSWC STANDARDS COMMITTEE

Alison Sweet

EDC MANAGER

6/15/26
DATE



Golden State
Water Company

A Subsidiary of American States Water Company

TITLE:

TYPICAL PUMP STATION
PRESSURE RELIEF RISER SECTION

SCALE:
NONE

DATE:
03/31/26

REV
2026

STANDARD DWG NO.
PS-3B

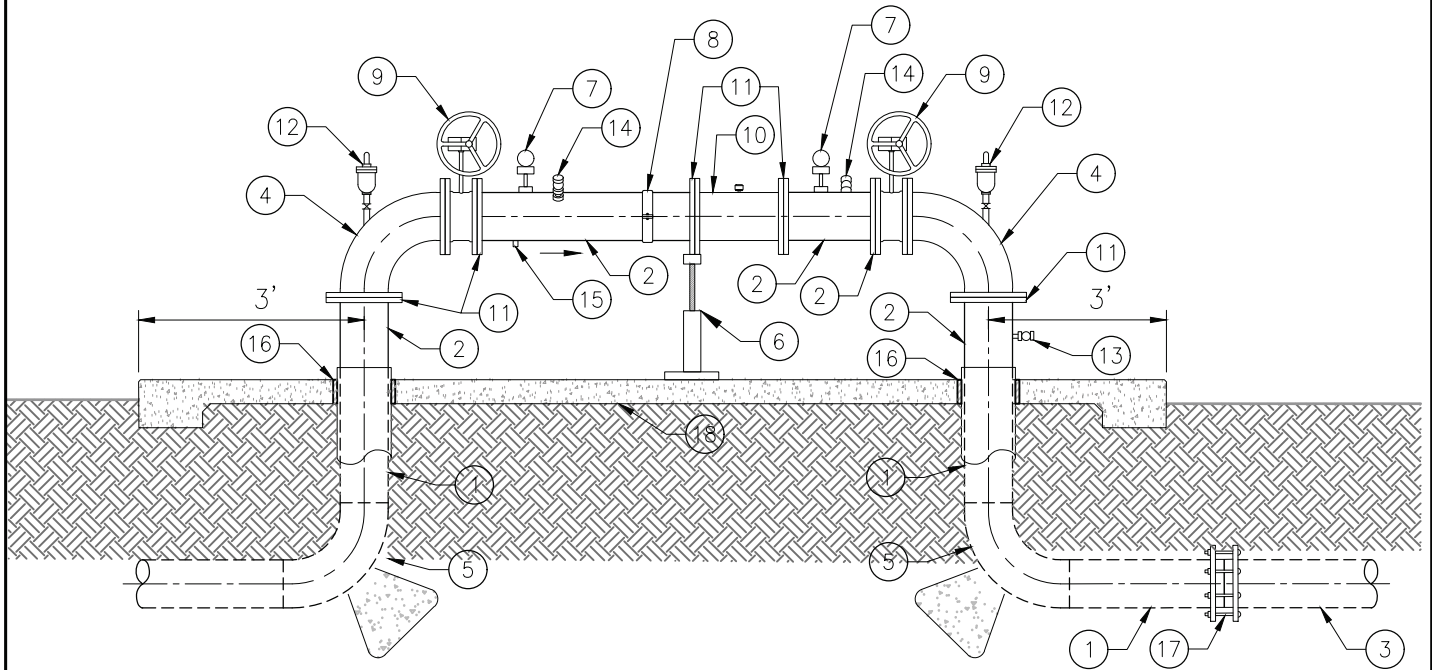

CONSTRUCTION NOTES:

- ① — WELDED STEEL (EPOXY LINED & CMC)
- ② — WELDED STEEL (EPOXY LINED)
- ③ — DUCTILE IRON PIPE
- ④ — FLANGED 90° ELBOW (EPOXY LINED)
- ⑤ — WELDED STEEL 90° ELBOW (EPOXY LINED & CMC)
- ⑥ — PIPE SUPPORT
- ⑦ — PRESSURE GAUGE AND TRANSMITTER
- ⑧ — VICTAULIC COUPLING, STYLE 77
- ⑨ — FLANGED BUTTERFLY VALVE (CL150)
- ⑩ — FLANGED MAG METER, MODEL UM08
- ⑪ — WELD-ON FLANGE
- ⑫ — AIR RELEASE AND VACUUM VALVE ASSEMBLY
- ⑬ — THREAD-O-LET FOR HOSE BIB & HBVB
- ⑭ — THREAD-O-LET FOR METER TEST
- ⑮ — THREAD-O-LET FOR DRAIN VALVE
- ⑯ — RTV SILICONE SELEANT
- ⑰ — FLEXIBLE COUPLING
- ⑱ — CONCRETE SLAB

APPROVED BY:
GSWC STANDARDS COMMITTEE

Alison Sweet

EDC MANAGER

6/15/26
DATE



Golden State
Water Company

A Subsidiary of American States Water Company

TITLE:

TYPICAL PUMP STATION
SINGLE METER RISER SECTION

SCALE:
NONE

DATE:
03/31/26

REV
2026

STANDARD DWG NO.
PS-3C

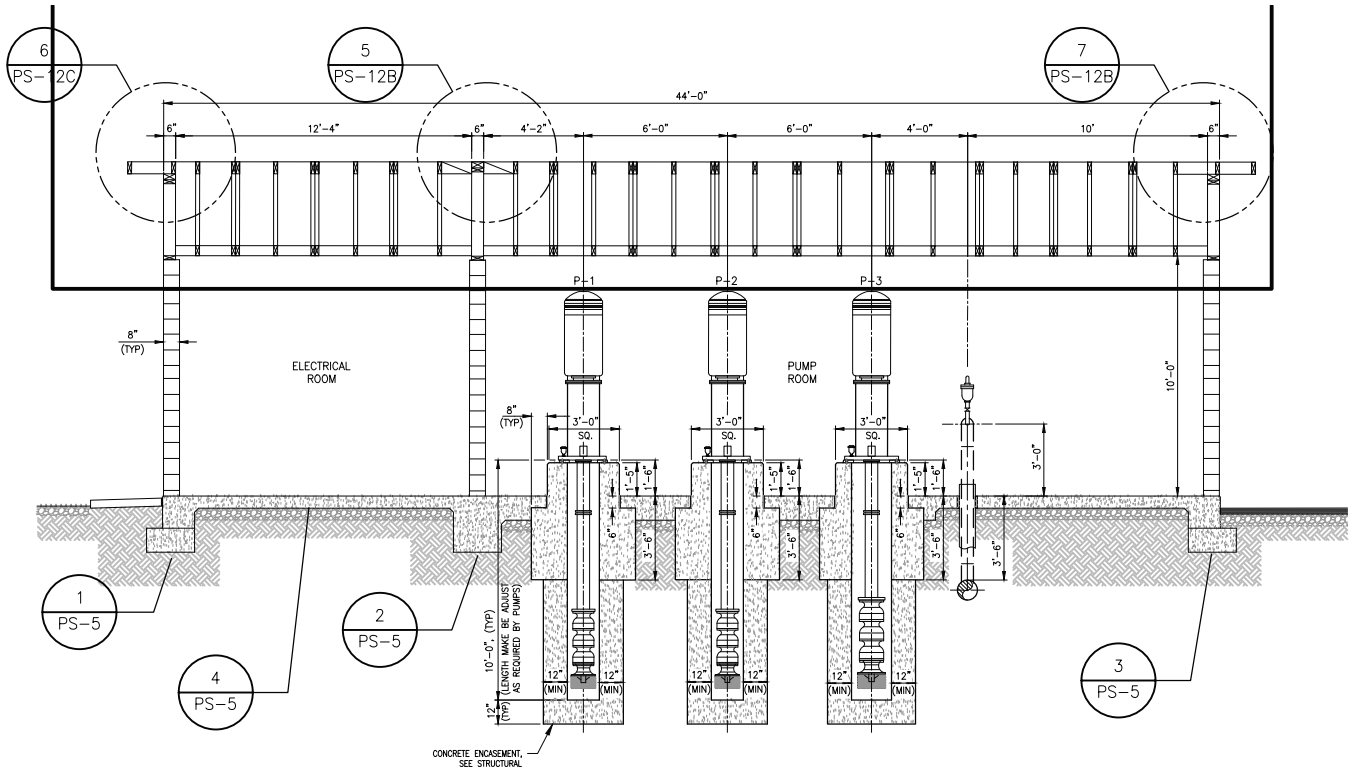

PUMP STATION BUILDING SECTION
NTS

NOTES:

1. All above ground steel pipe and fittings shall be epoxy lined and painted per the specifications.
2. All underground steel piping and fittings shall be epoxy lined and cement mortar coated. Coating shall terminate at 4 inches above concrete.
3. All epoxy coating damaged by welding or field installation shall be repaired per the specifications.
4. Flanged connections between ductile iron pipe and valves and steel pipe shall include an insulating gasket to electrically isolate each metal surface from the other.
5. Above ground valves will be supplied with handwheels unless permanent location is outside of pump building.
6. All buried ductile iron pipe, fittings, and valves shall be encased with 8 mil thick polyethylene encasement which shall be in accordance with the manufacturer's recommendations and AWWA standard C105.
7. All buried flexible and mechanical joint pipe connections shall be fully restrained.
8. Building may be optional.
9. Can diameter depends on designed pump size.

APPROVED BY:
GSWC STANDARDS COMMITTEE

Alison Sweet

EDC MANAGER

6/15/26
DATE



Golden State
Water Company

A Subsidiary of American States Water Company

TITLE:

FRONT VIEW
PUMP AND PIPING SECTION

SCALE:
NONE

DATE:
03/31/26

REV
2026

STANDARD DWG NO.
PS-3D

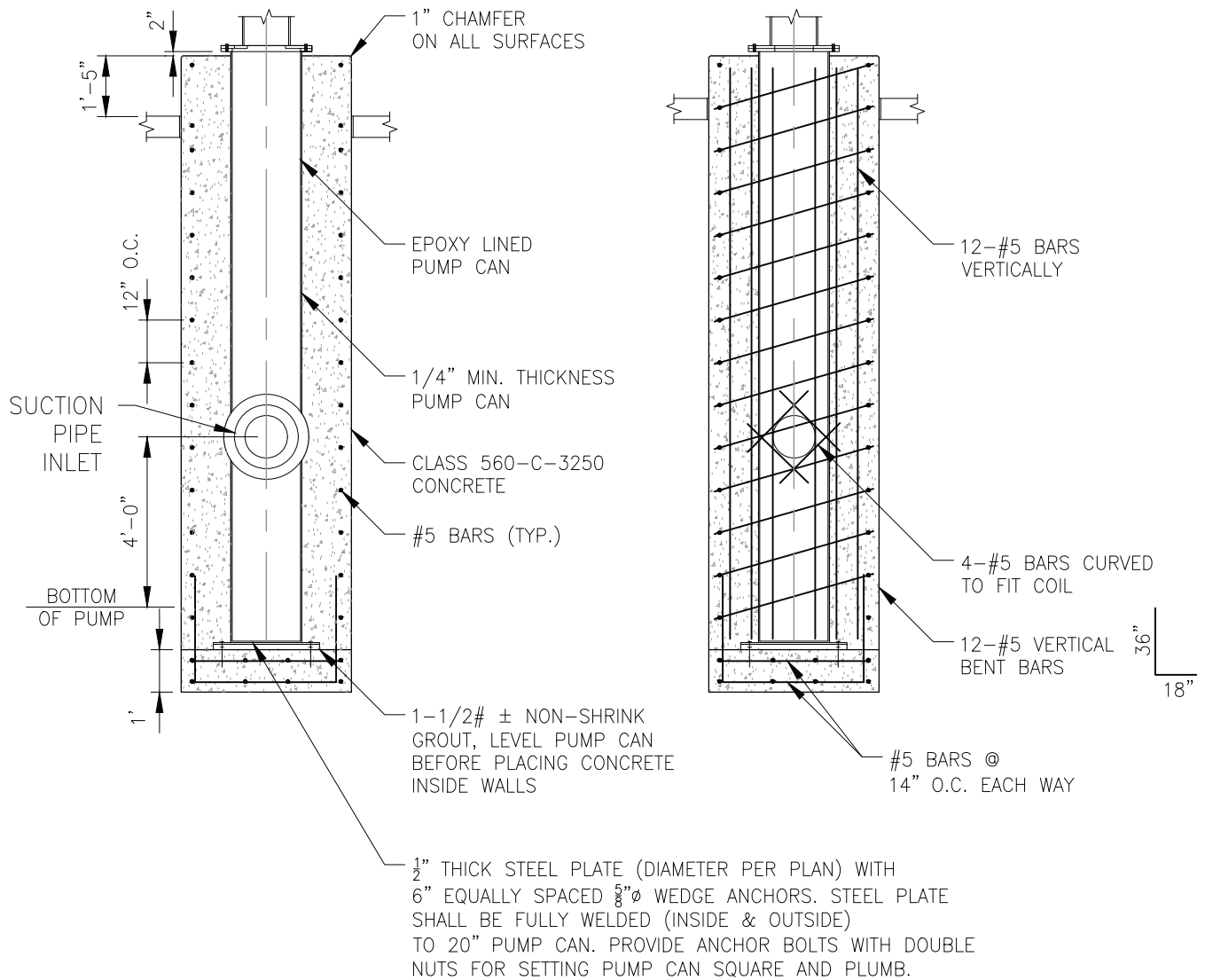
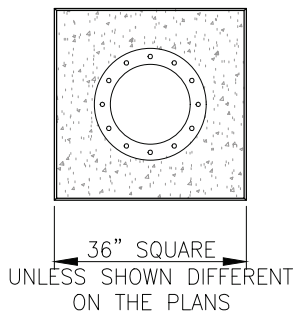

TYPICAL REINFORCED CONCRETE PUMP CAN
(OPTION 2)

APPROVED BY:
GSWC STANDARDS COMMITTEE

Alison Sweet

EDC MANAGER

6/15/26
DATE



Golden State
Water Company

A Subsidiary of American States Water Company

TITLE:

TYPICAL PUMP STATION
BUILDING AND PIPING SECTION

SCALE:
NONE

DATE:
07/31/23

REV
2024

STANDARD DWG NO.
PS-3E

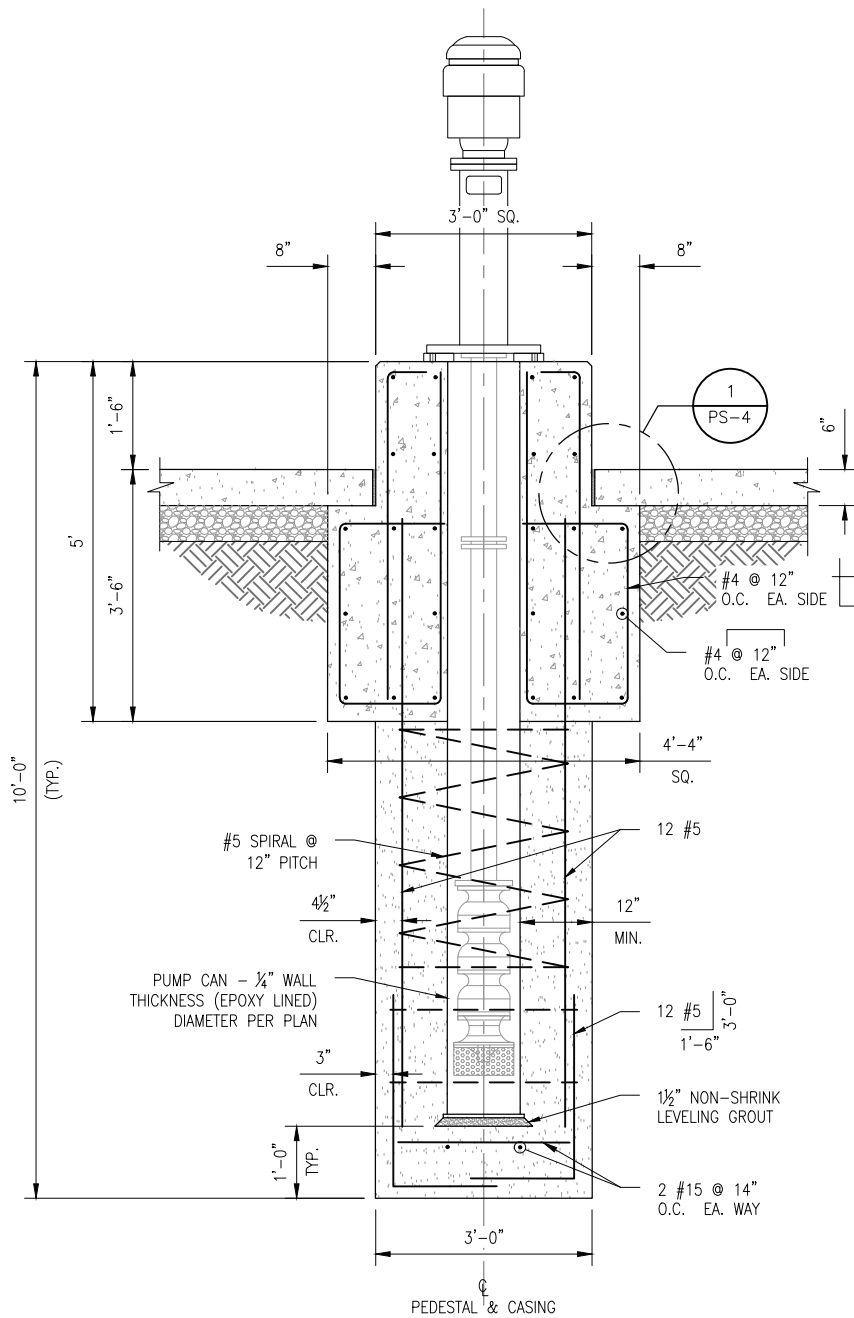

TYPICAL REINFORCED CONCRETE PUMP CAN

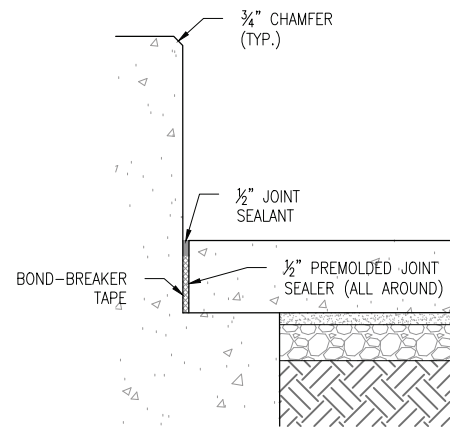

SLAB ISOLATION JOINT AT PUMP BASE

1
-

APPROVED BY:
GSWC STANDARDS COMMITTEE

Alison Sweet

EDC MANAGER

6/15/26
DATE



Golden State
Water Company

A Subsidiary of American States Water Company

TITLE:

TYPICAL PUMP CAN
CONSTRUCTION

SCALE:
NONE

DATE:
07/31/23

REV
2024

STANDARD DWG NO.
PS-4

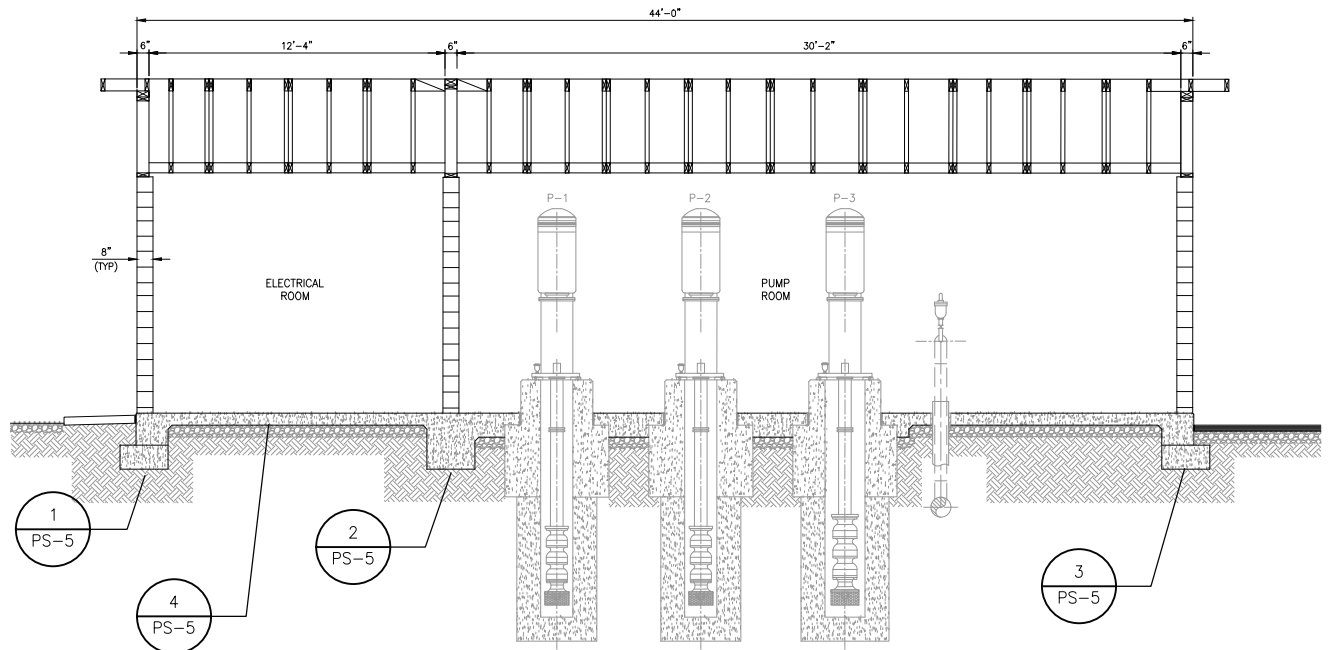

PUMP STATION BUILDING SECTION
NTS

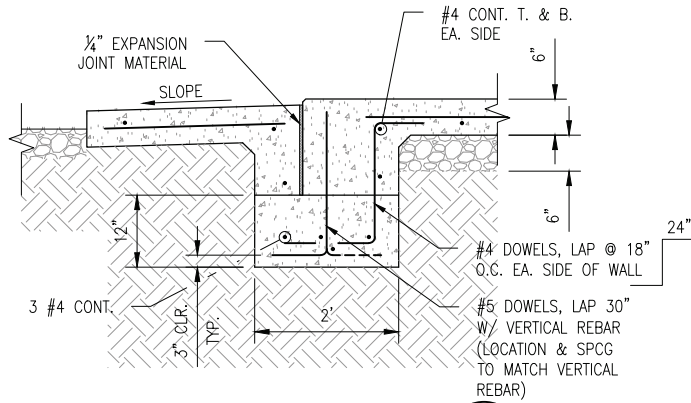

EXTERIOR WALL FOOTING 1
NTS

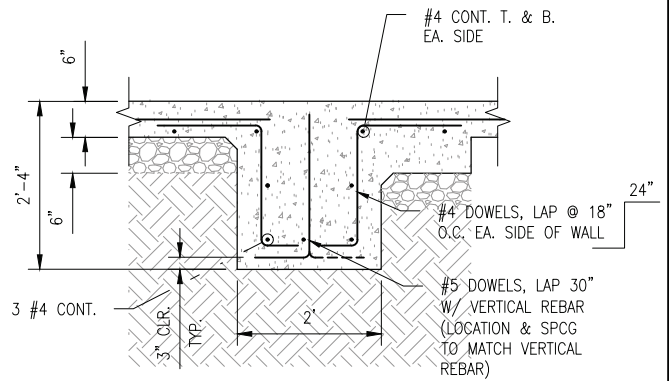

INTERIOR WALL FOOTING 2
NTS

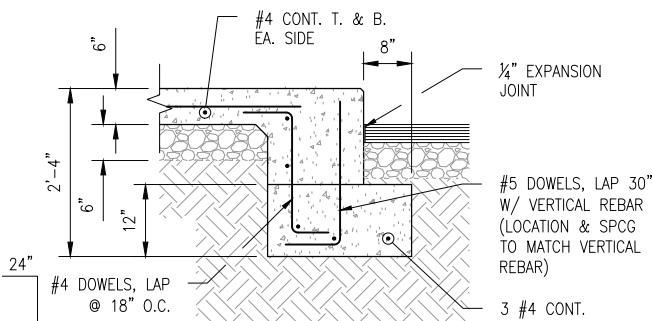

EXTERIOR WALL FOOTING 3
NTS

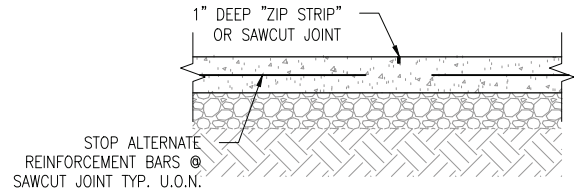

SLAB ON GRADE JOINT 4
NTS

NOTES:

1. The footings, foundation, and slab shall be placed on 6" thick crushed rock.
2. Use a slab isolation joint where the slab meets the pump bases.
3. Use a slab on grade joint to prevent cracking.

APPROVED BY:
GSWC STANDARDS COMMITTEE

Alison Sweet

EDC MANAGER

6/15/26
DATE



Golden State
Water Company

A Subsidiary of American States Water Company

TITLE:

**SLAB, FOOTING, AND FOUNDATION
SECTION AND DETAILS**

SCALE:
NONE

DATE:
04/17/26

REV
2026

STANDARD DWG NO.
PS-5

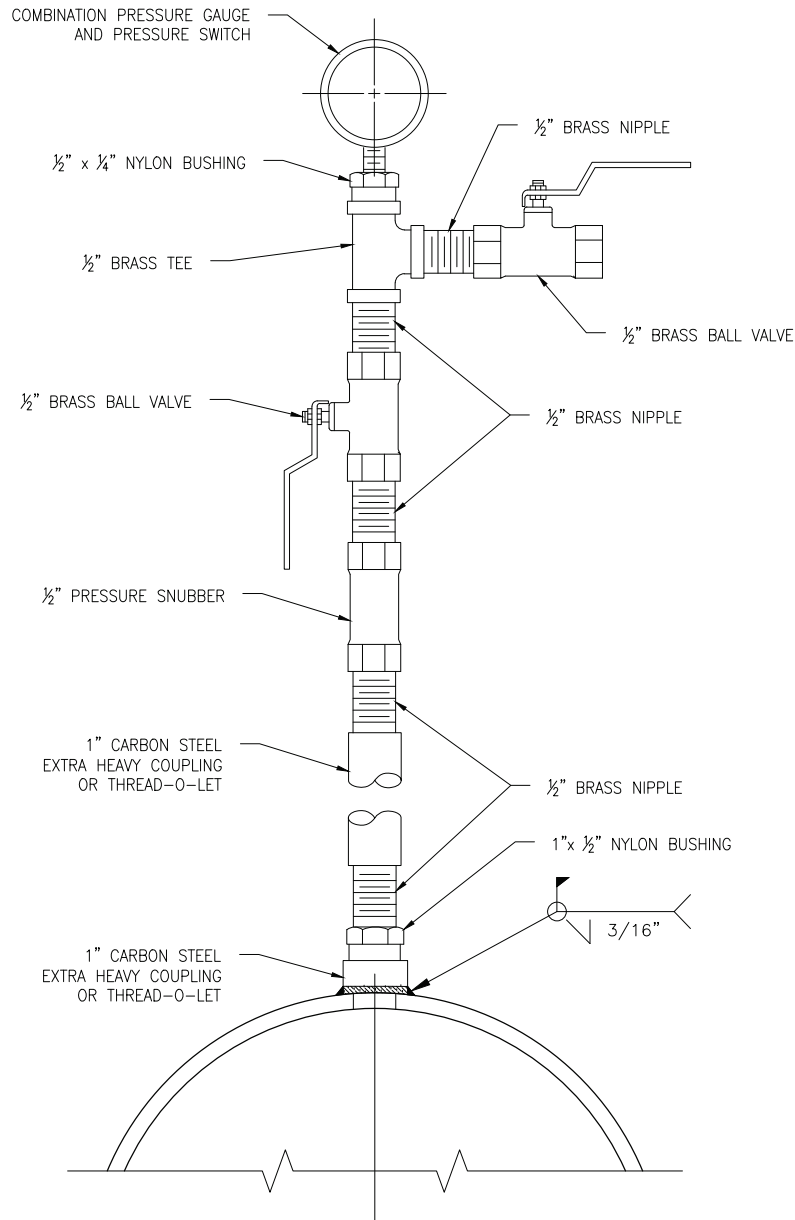

NOTES:

1. Assembly should be made as short as possible by minimizing lengths of brass nipples.
2. All dissimilar metals shall be isolated from each other by use of nylon bushings.

APPROVED BY:
GSWC STANDARDS COMMITTEE

Alison Sweet

EDC MANAGER

6/15/26
DATE



Golden State
Water Company

A Subsidiary of American States Water Company

TITLE:

PRESSURE SWITCH / TRANSMITTER
AND GAUGE ASSEMBLY DETAIL

SCALE:
NONE

DATE:
07/31/23

REV
2024

STANDARD DWG NO.
PS-6

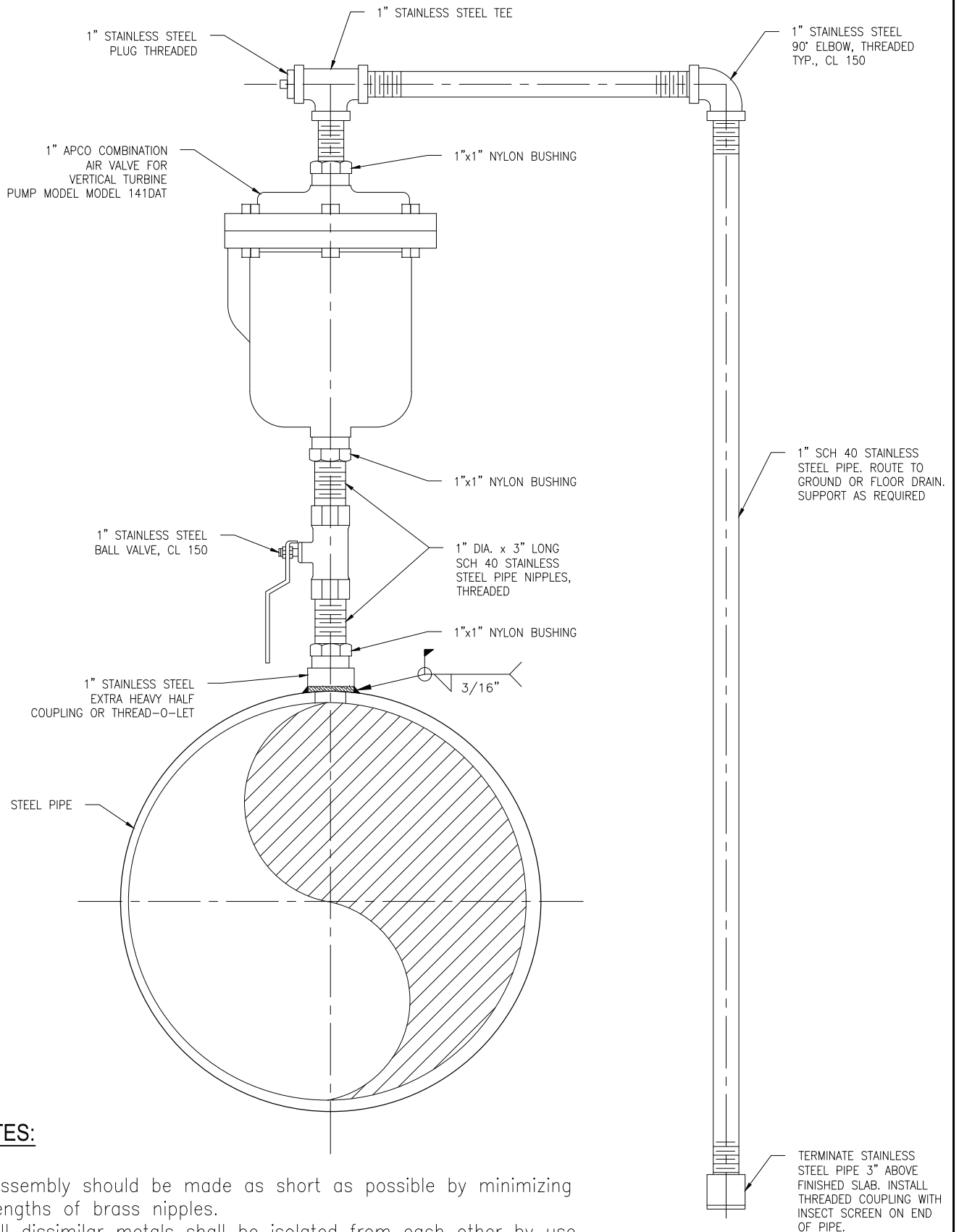

NOTES:

1. Assembly should be made as short as possible by minimizing lengths of brass nipples.
2. All dissimilar metals shall be isolated from each other by use of nylon bushings.

APPROVED BY:
GSWC STANDARDS COMMITTEE

Alison Sweet

EDC MANAGER

6/15/26
DATE



Golden State
Water Company

A Subsidiary of American States Water Company

TITLE:

**1" COMBINATION AIR RELEASE
AND VACUUM RELIEF VALVE
ASSEMBLY**

SCALE:
NONE

DATE:
07/31/23

REV
2024

STANDARD DWG NO.
PS-7

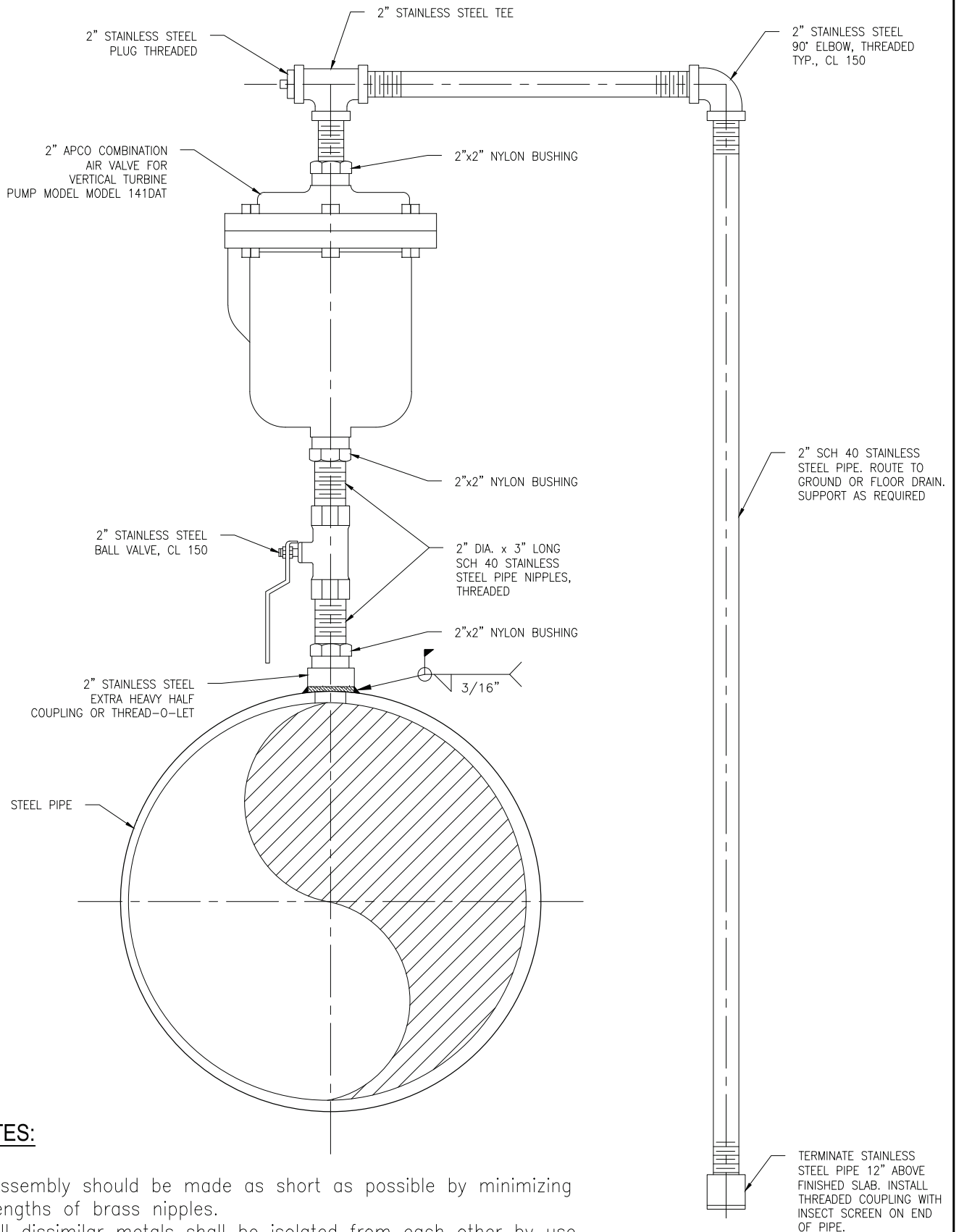

NOTES:

1. Assembly should be made as short as possible by minimizing lengths of brass nipples.
2. All dissimilar metals shall be isolated from each other by use of nylon bushings.

APPROVED BY:
GSWC STANDARDS COMMITTEE

Alison Sweet

EDC MANAGER

6/15/26
DATE



Golden State
Water Company

A Subsidiary of American States Water Company

TITLE:

**2" COMBINATION AIR RELEASE
AND VACUUM RELIEF VALVE
ASSEMBLY**

SCALE:
NONE

DATE:
04/17/26

REV
2026

STANDARD DWG NO.
PS-8

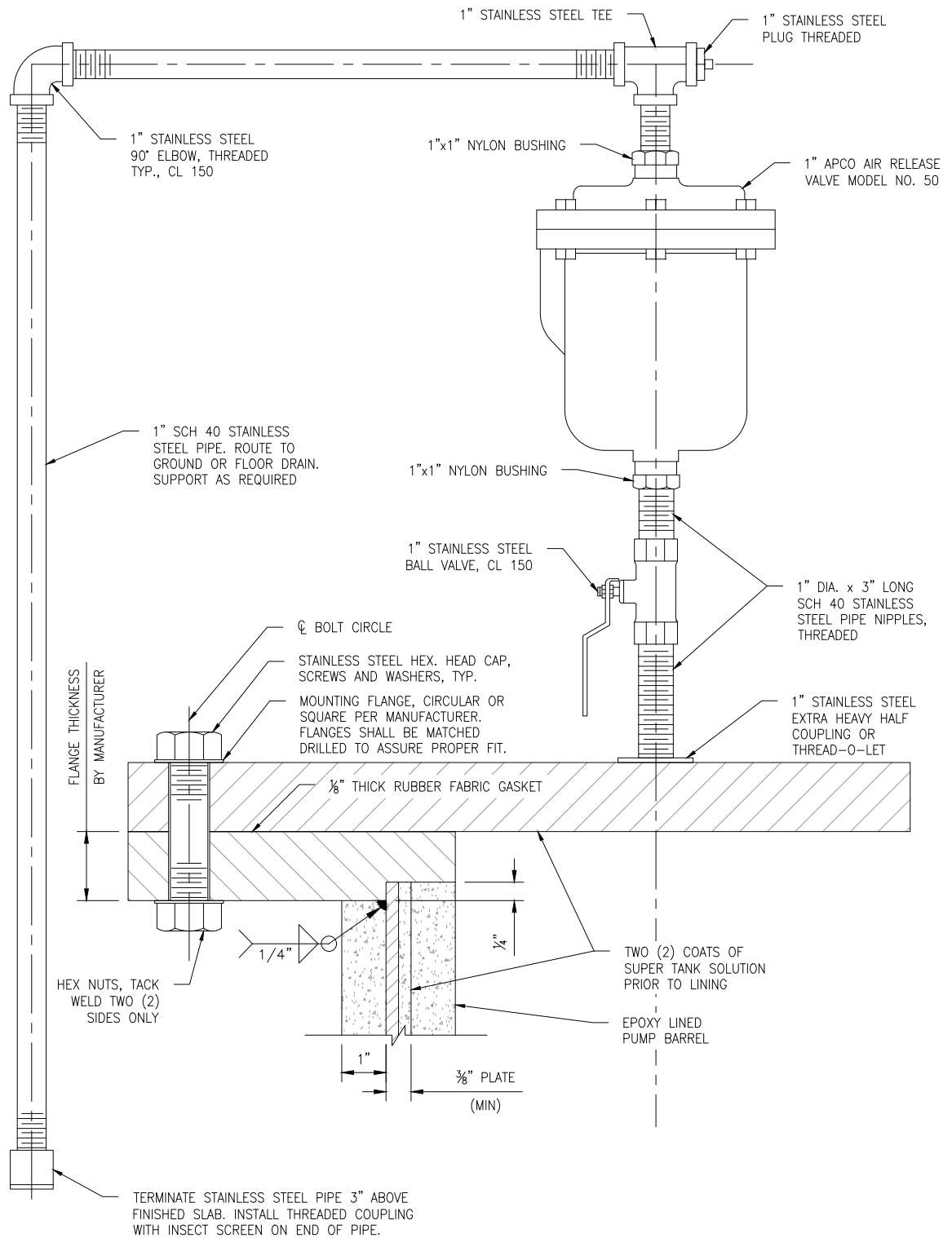

NOTE:

1. Detail shall be revised as necessary per particular manufacturer shop drawing requirements.
2. Assembly should be made as short as possible by minimizing lengths of brass nipples.
3. All dissimilar metals shall be isolated from each other by use of nylon bushings.

APPROVED BY:
GSWC STANDARDS COMMITTEE

Alison Sweet

EDC MANAGER

6/15/26
DATE



Golden State
Water Company

A Subsidiary of American States Water Company

TITLE:

**1" COMBINATION AIR RELEASE
AND VACUUM RELIEF VALVE
ASSEMBLY FOR PUMP BARREL**

SCALE:
NONE

DATE:
07/31/23

REV
2024

STANDARD DWG NO.
PS-9

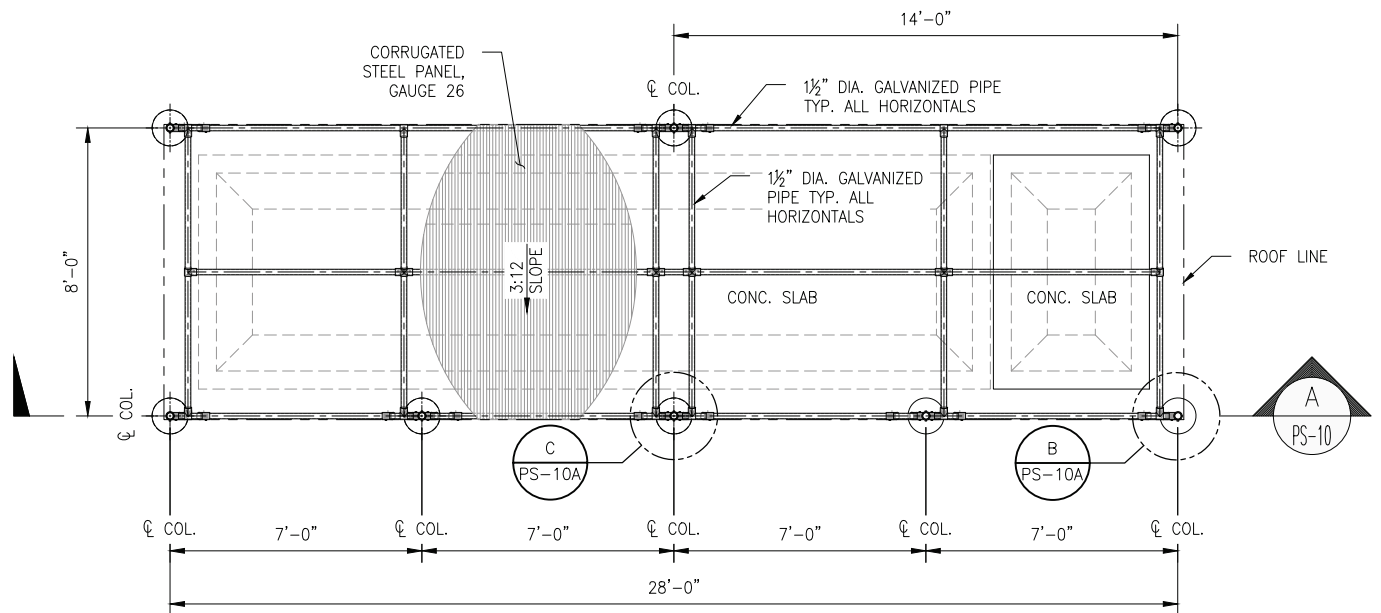

CANOPY PLAN VIEW
NTS

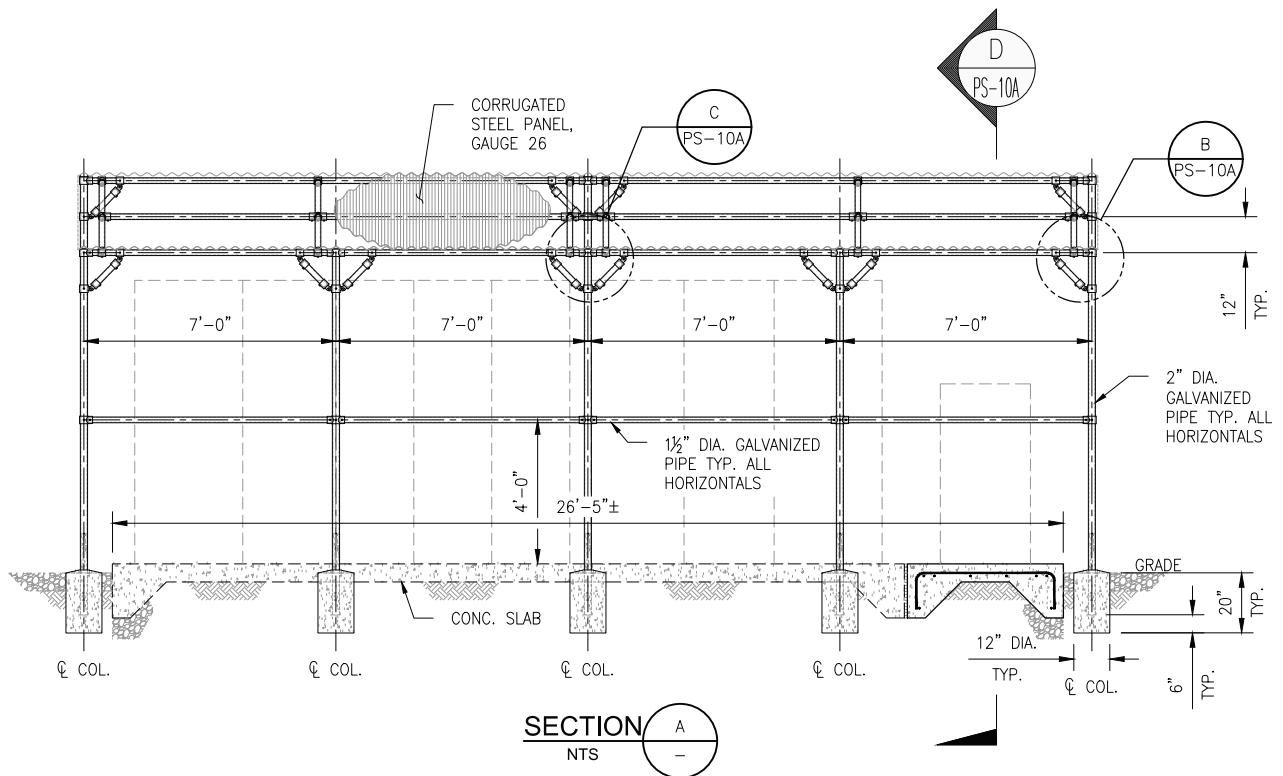

SECTION A
NTS

NOTE:

1. Provide as necessary 1/4" dia. weep holes at all post columns above mortar fill level. seal exposed metal as required.
2. Cap all open pipe ends as required.
3. Field verify and match for new electrical equipment pad.
4. Mortar filled posts to 12" of pipe.

APPROVED BY:
GSWC STANDARDS COMMITTEE

Alison Sweet

EDC MANAGER

6/15/26
DATE



Golden State
Water Company

A Subsidiary of American States Water Company

TITLE:

OUTDOOR PUMP STATION CANOPY
PLAN

SCALE:
NONE

DATE:
07/31/23

REV
2024

STANDARD DWG NO.
PS-10A

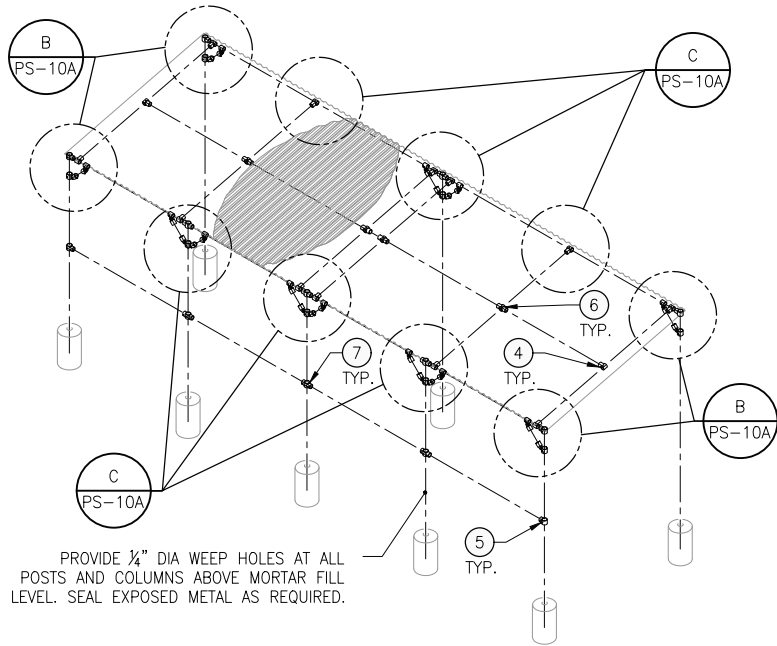

CANOPY ISOMETRIC VIEW
NTS

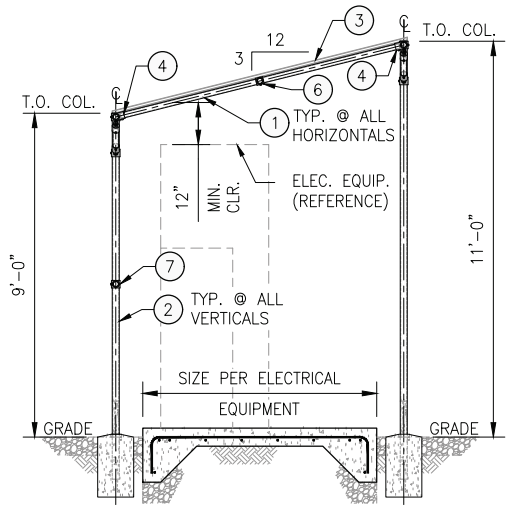

SECTION D
NTS

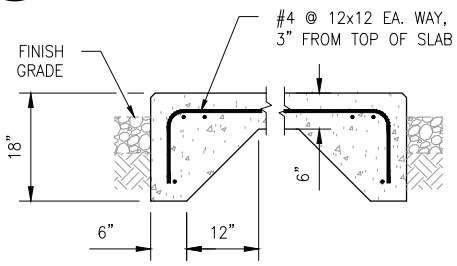

SLAB DETAIL
NTS

- CONSTRUCTION NOTES**
- ① — 1½" DIA. GALVANIZED PIPE
 - ② — 2" DIA. GALVANIZED PIPE
 - ③ — SEMCO CORRUGATED STEEL PANEL, GAUGE 26
 - ④ — SINGLE SOCKET TEE (KEE KLAMP 10-8)
 - ⑤ — SINGLE SOCKET TEE (KEE KLAMP 10-98)
 - ⑥ — TWO SOCKET CROSS (KEE KLAMP 26-8)
 - ⑦ — TWO SOCKET CROSS (KEE KLAMP 26-98)
 - ⑧ — FEMALE SINGLE SWIVEL SOCKET MEMBER (KEE KLAMP F50-8)
 - ⑨ — MALE SINGLE SWIVEL SOCKET MEMBER (KEE KLAMP M50-8)
 - ⑩ — MALE SINGLE SWIVEL SOCKET MEMBER (KEE KLAMP M50-9)
 - ⑪ — MALE SINGLE SWIVEL SOCKET MEMBER (KEE KLAMP M51-9)

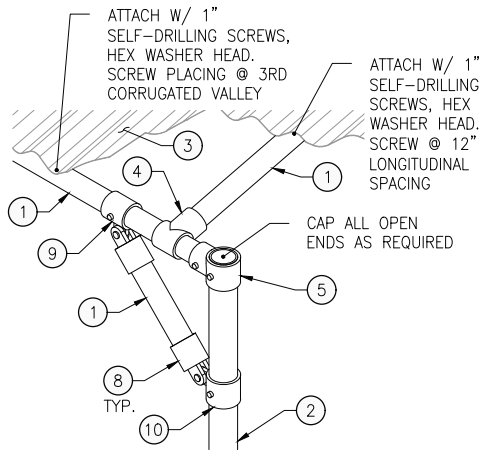

CONNECTION DETAIL B
NTS

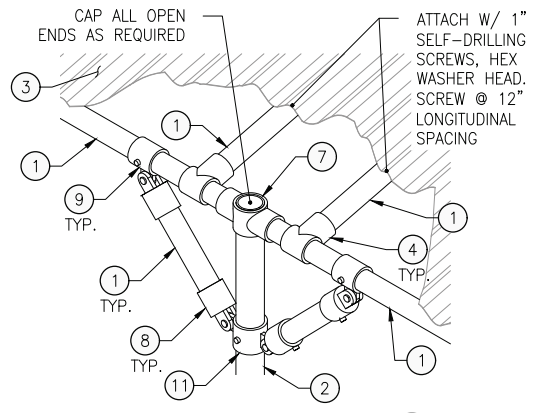

CONNECTION DETAIL C
NTS

APPROVED BY:
GSWC STANDARDS COMMITTEE

Alison Sweet
EDC MANAGER

6/15/26
DATE



TITLE: OUTDOOR PUMP STATION CANOPY DETAILS			
SCALE: NONE	DATE: 07/31/23	REV: 2024	STANDARD DWG NO. PS-10B

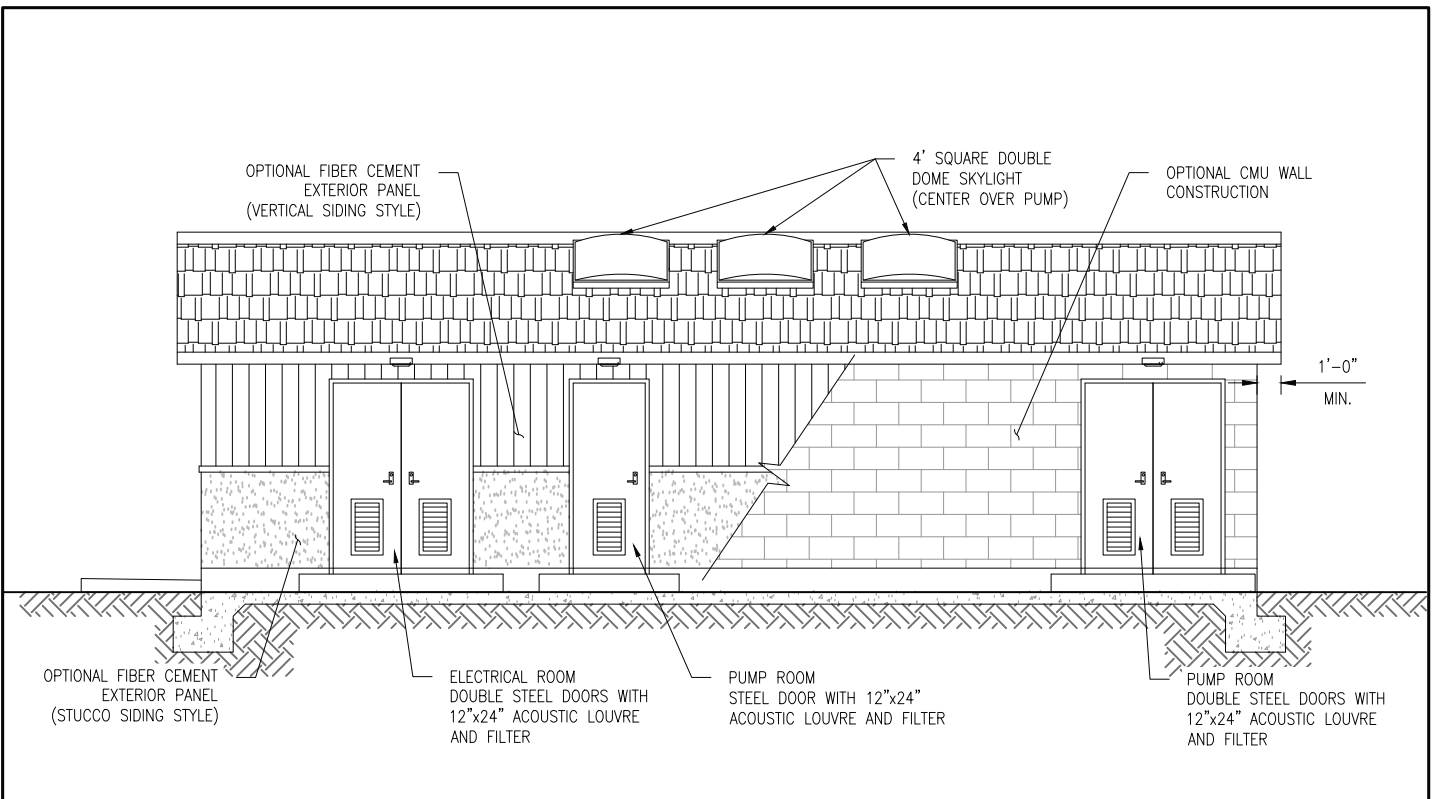

FRONT ELEVATION
N.T.S.

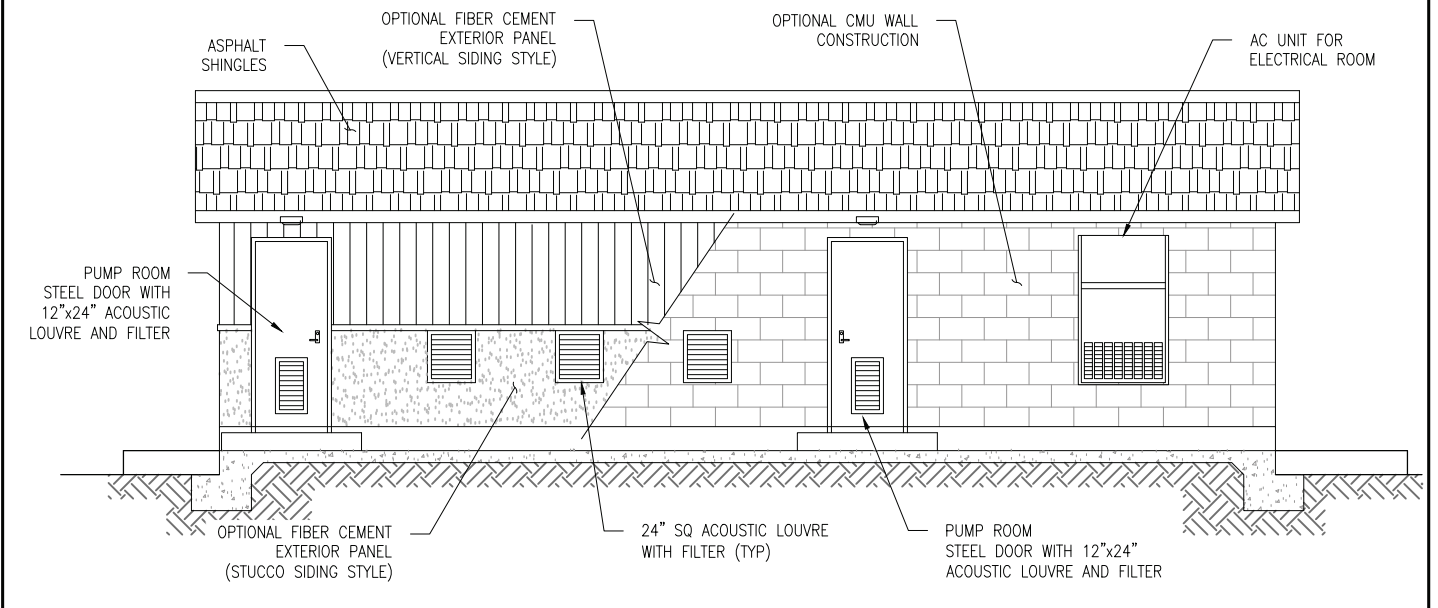

REAR ELEVATION
N.T.S.

APPROVED BY:
GSWC STANDARDS COMMITTEE

Alison Sweet

EDC MANAGER

6/15/26
DATE



Golden State
Water Company

A Subsidiary of American States Water Company

TITLE:

ARCHITECTURAL VIEWS OF
PUMP BUILDING

SCALE:
NONE

DATE:
04/14/26

REV
2026

STANDARD DWG NO.
PS-11A

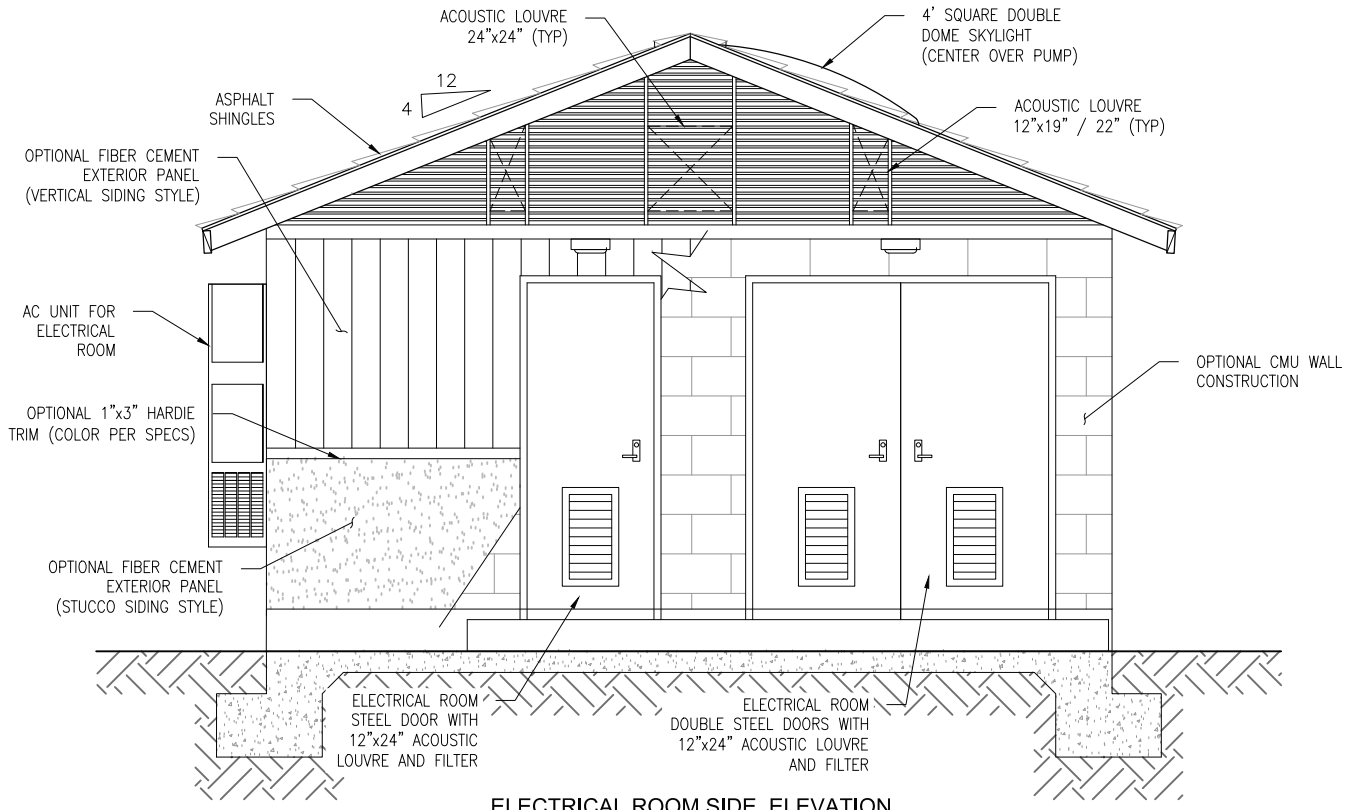

ELECTRICAL ROOM SIDE ELEVATION
N.T.S.

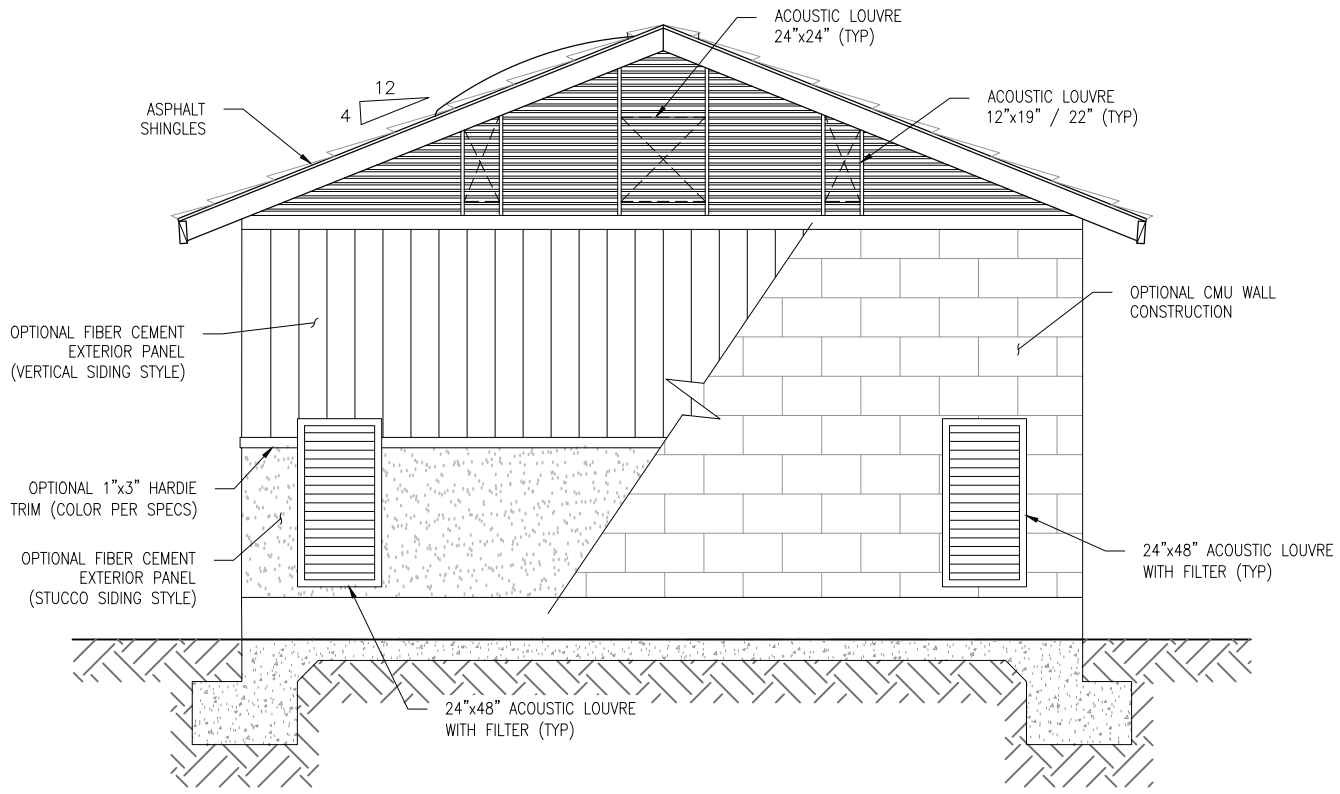

PUMP ROOM SIDE ELEVATION
N.T.S.

APPROVED BY:
GSWC STANDARDS COMMITTEE

Alison Sweet
EDC MANAGER

6/15/26
DATE



TITLE: ARCHITECTURAL VIEWS OF PUMP BUILDING			
SCALE: NONE	DATE: 04/14/26	REV: 2026	STANDARD DWG NO. PS-11B

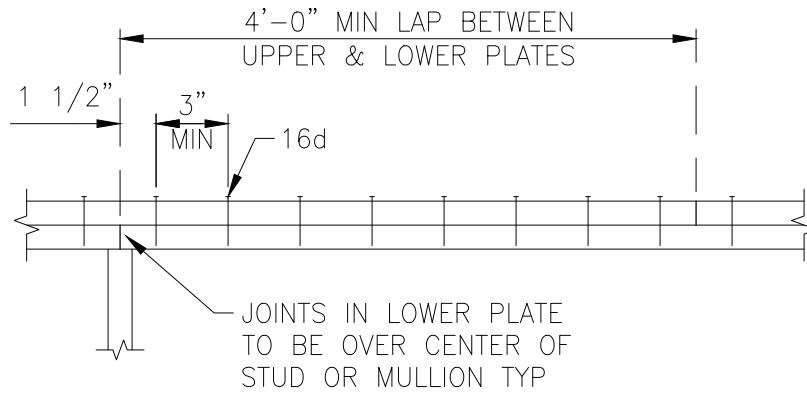

NAILED SPLICE

N.T.S.

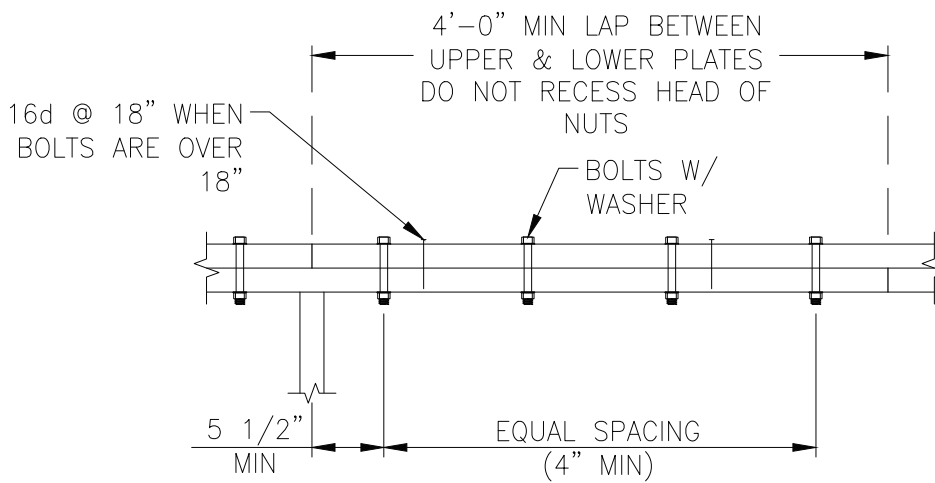

BOLTED SPLICE

N.T.S.

SPLICE	FASTENER	LOAD (LBS)
A	8-16d	1138
B	10-16d	1423
C	12-16d	1707

NOTES:

1. Number of nails or bolts listed shall be used each side of upper & lower plate joint.
2. Minimum splice nailing: (2) rows of 16d @ 12".
3. When 2x & 3x top plate occurs, nailing shall apply thru 2x.
4. If double top plate is intermitted for any reason, splice w/ Simpson 'MSTA36'.

APPROVED BY:
GSWC STANDARDS COMMITTEE

Alison Sweet

EDC MANAGER

6/15/26
DATE



Golden State
Water Company

A Subsidiary of American States Water Company

TITLE:

TOP PLATE SPLICE

SCALE:
NONE

DATE:
07/31/23

REV
2024

STANDARD DWG NO.
PS-12

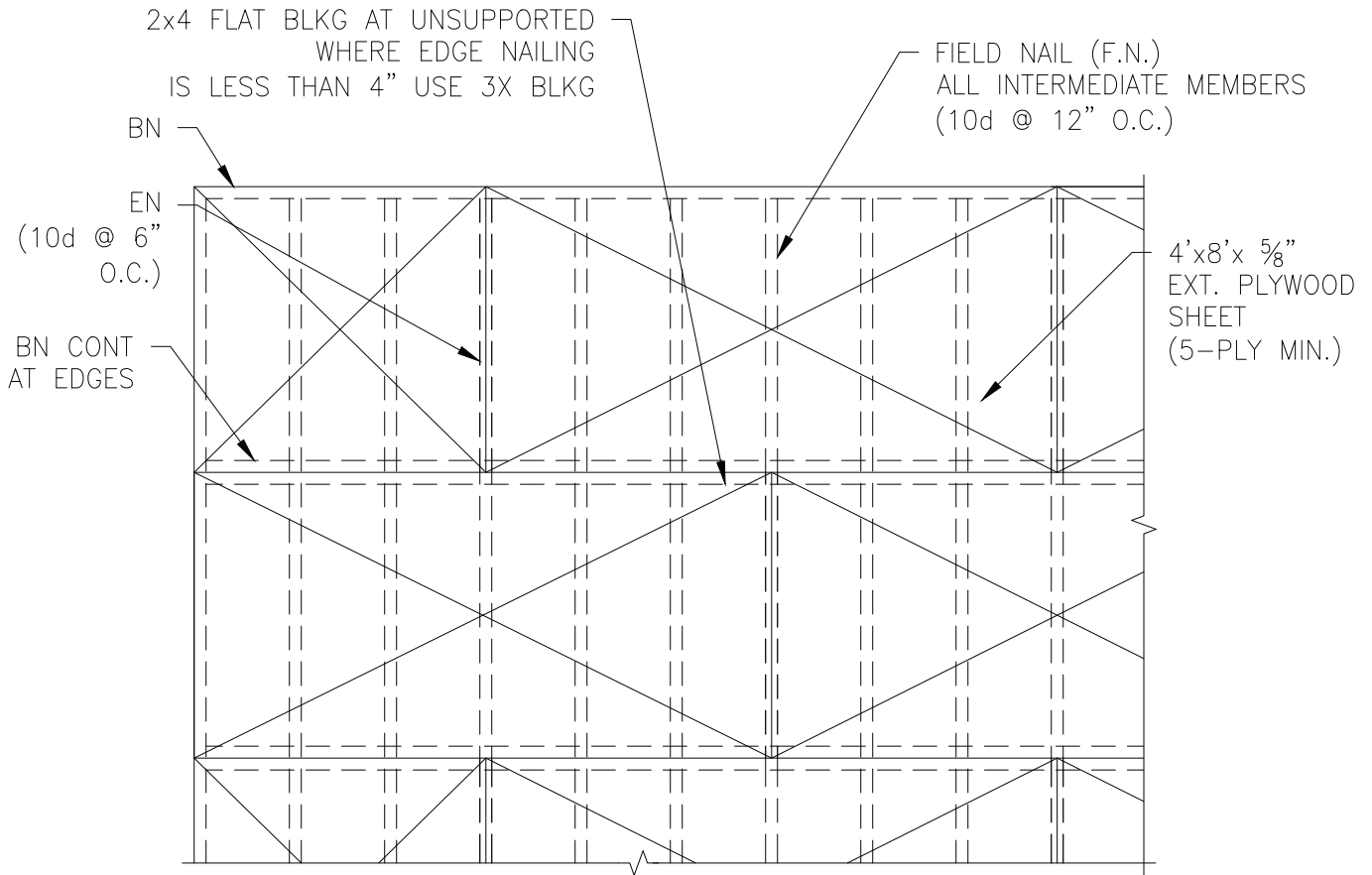

ROOF DIAPHRAGM NAILING
N.T.S.

NOTES:

1. Minimum plywood sheet size shall be 2'-0" x 4'-0". Long dimension of plywood shall span across joists or rafters.
2. Minimum 3/8" nailing edge distance.
3. Boundary nail (B.N.) over all beams and around all openings (10d @ 6" O.C.).
4. Plywood sheathing shall be laid perpendicular to framing with 4'-0" staggered joints.
5. All floor sheathing should be glued to framing member with A.P.A. approved adhesive.
6. Diaphragm sheathing nails or other approved sheathing connector shall be driven so that their head or crown is flush w/ the surface of the sheathing.
7. Block all unsupported edges with 2x4 flat (typ), with face grain perpendicular to framing.

APPROVED BY:
GSWC STANDARDS COMMITTEE

Alison Sweet

EDC MANAGER

6/15/26
DATE



Golden State
Water Company

A Subsidiary of American States Water Company

TITLE:

**HORIZONTAL ROOF DIAPHRAGM
NAILING**

SCALE:
NONE

DATE:
07/31/23

REV
2024

STANDARD DWG NO.
PS-13

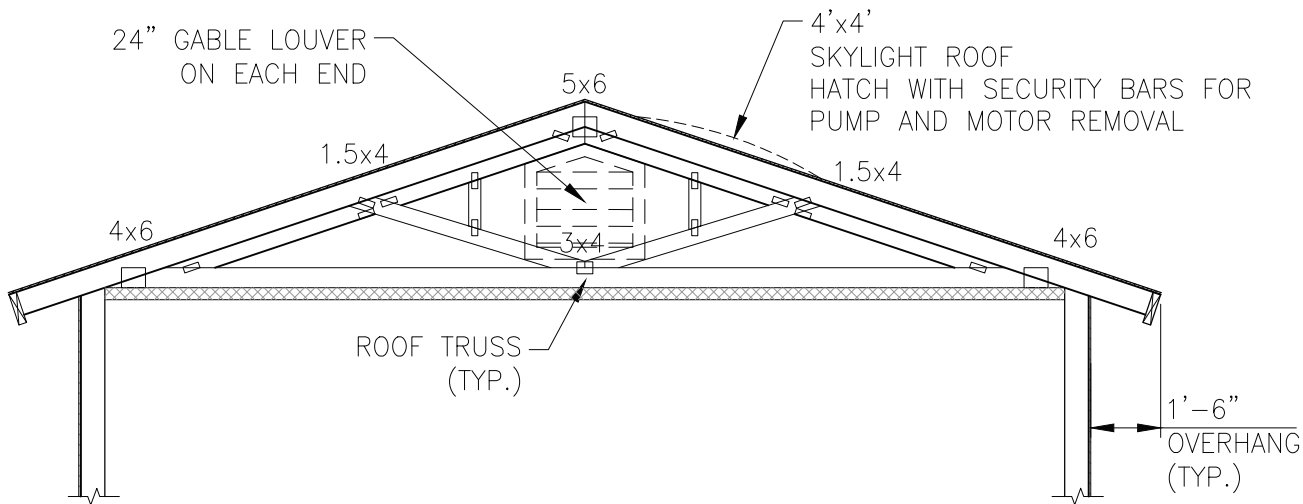

ROOF
N.T.S.

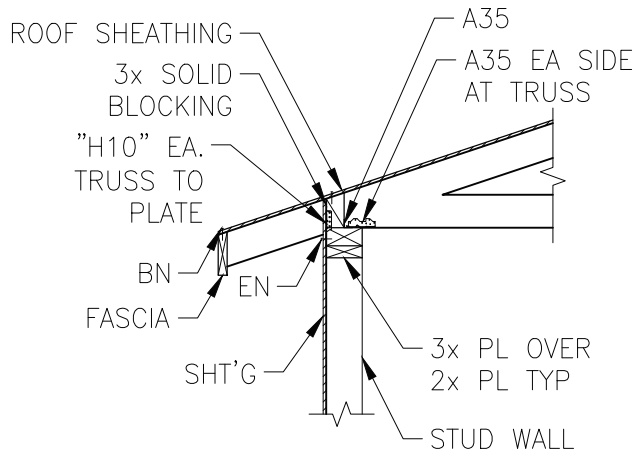

FRAMING
N.T.S.

1
PS-3A

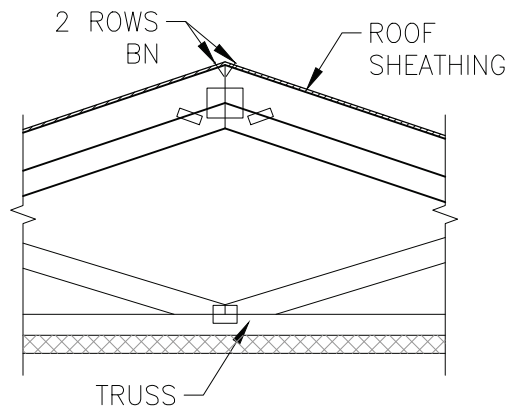

FRAMING
N.T.S.

3
PS-3A

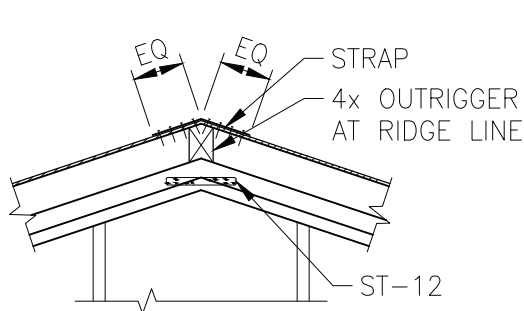

FRAMING
N.T.S.

2
PS-3A

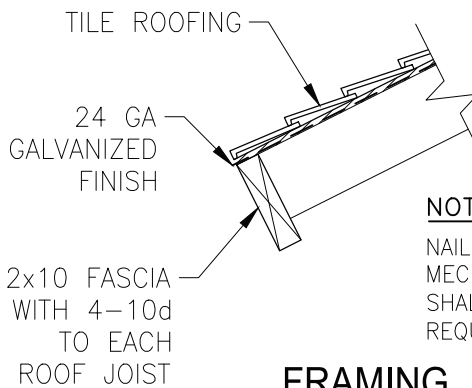

FRAMING
N.T.S.

4
PS-3A

NOTE:

NAILING AND FASTENING OF MECHANICAL CONNECTORS SHALL BE PER MANUFACTURER'S REQUIREMENTS.

APPROVED BY:
GSWC STANDARDS COMMITTEE

Alison Sweet

EDC MANAGER

6/15/26
DATE



Golden State
Water Company

A Subsidiary of American States Water Company

TITLE:

ROOF FRAMING DETAILS

SCALE:	DATE:	REV	STANDARD DWG NO.
NONE	07/31/23	2024	PS-14A

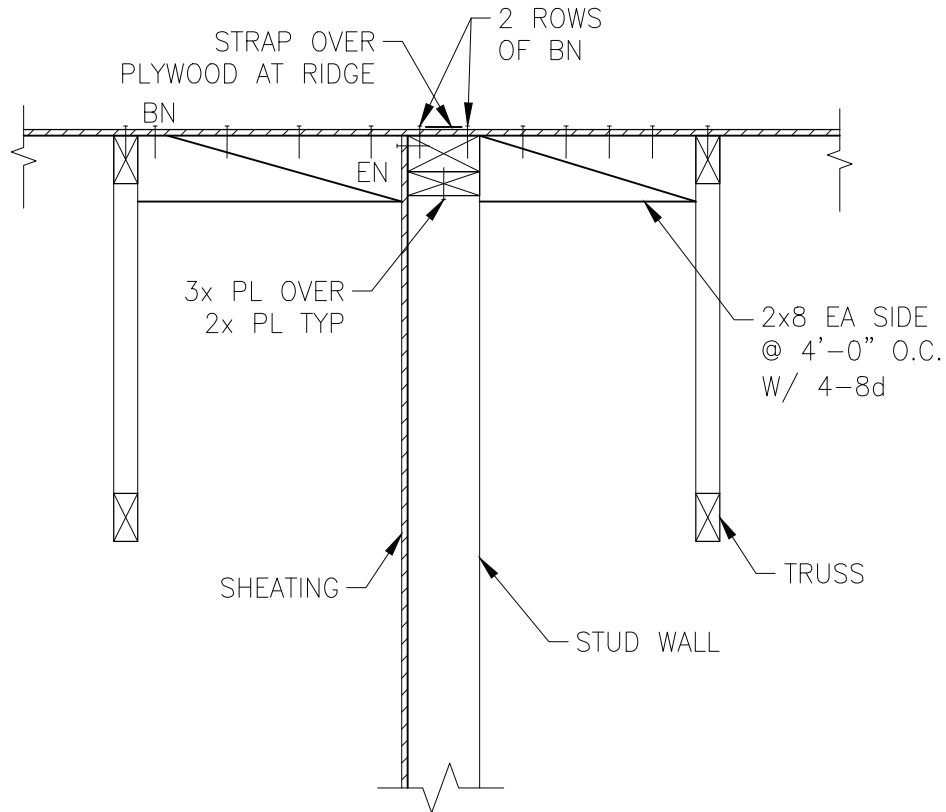

FRAMING

N.T.S.

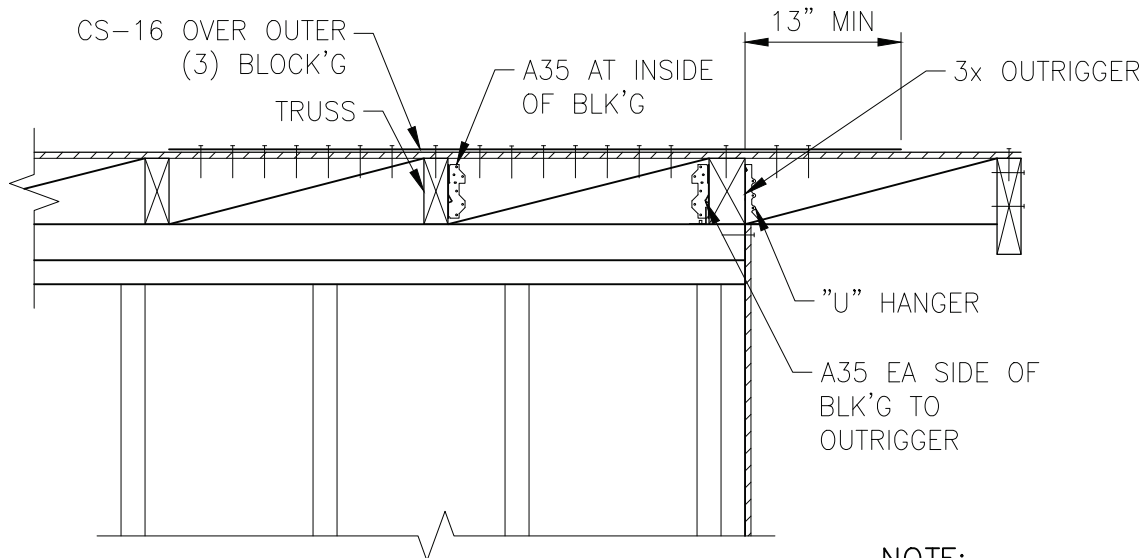

FRAMING

N.T.S.



NOTE:

NAILING AND FASTENING OF MECHANICAL CONNECTORS SHALL BE PER MANUFACTURER'S REQUIREMENTS.

APPROVED BY:
GSWC STANDARDS COMMITTEE

Alison Sweet

EDC MANAGER

6/15/26
DATE



Golden State
Water Company

A Subsidiary of American States Water Company

TITLE:

ROOF FRAMING DETAILS

SCALE:	DATE:	REV	STANDARD DWG NO.
NONE	07/31/23	2024	PS-14B

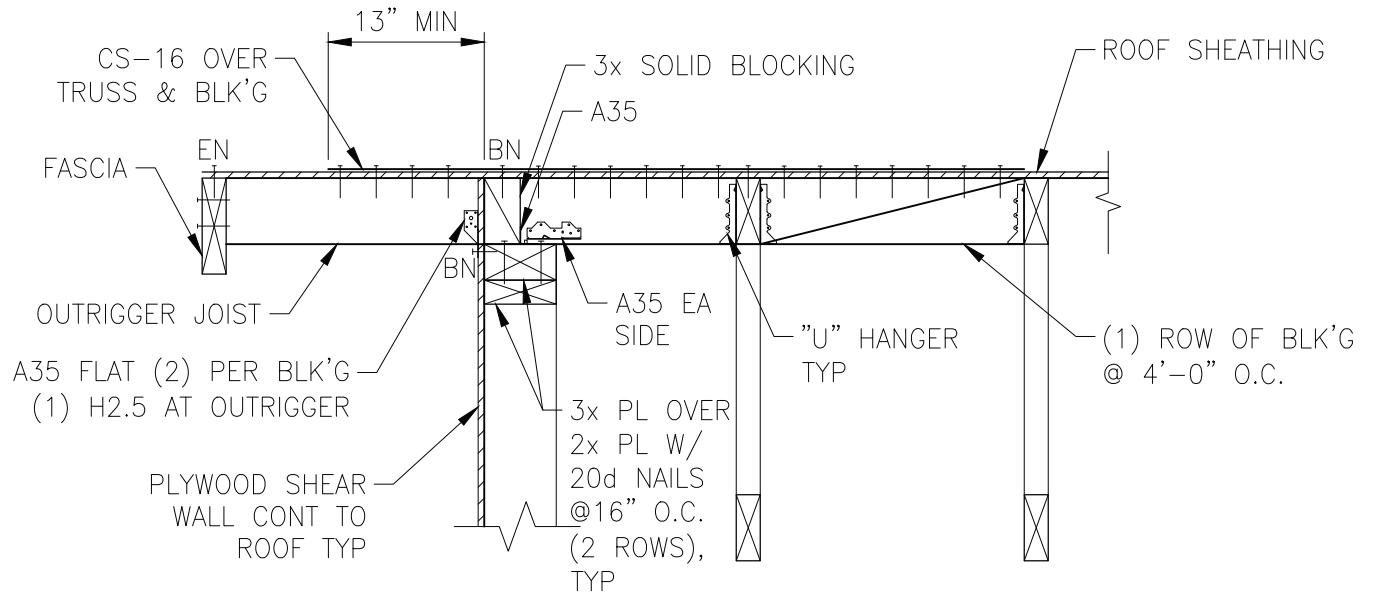

FRAMING

N.T.S.



NOTE:

NAILING AND FASTENING OF MECHANICAL CONNECTORS SHALL BE PER MANUFACTURER'S REQUIREMENTS.

APPROVED BY:
GSWC STANDARDS COMMITTEE

Alison Sweet

EDC MANAGER

6/15/26
DATE



Golden State
Water Company

A Subsidiary of American States Water Company

TITLE:

ROOF FRAMING DETAILS

SCALE:
NONE

DATE:
07/31/23

REV
2024

STANDARD DWG NO.
PS-14C

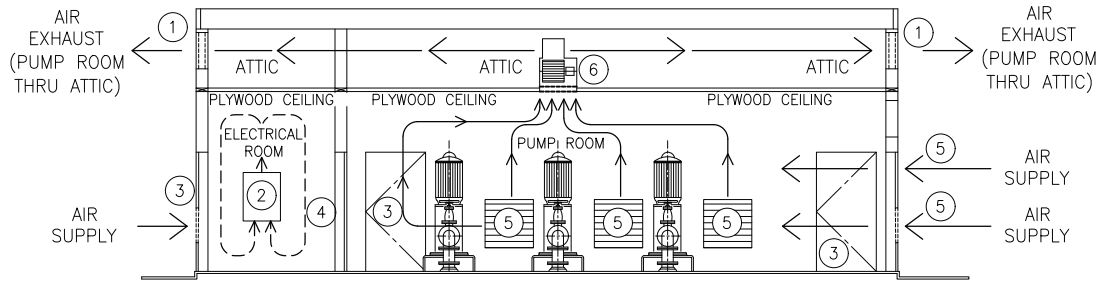

SECTION
N.T.S.

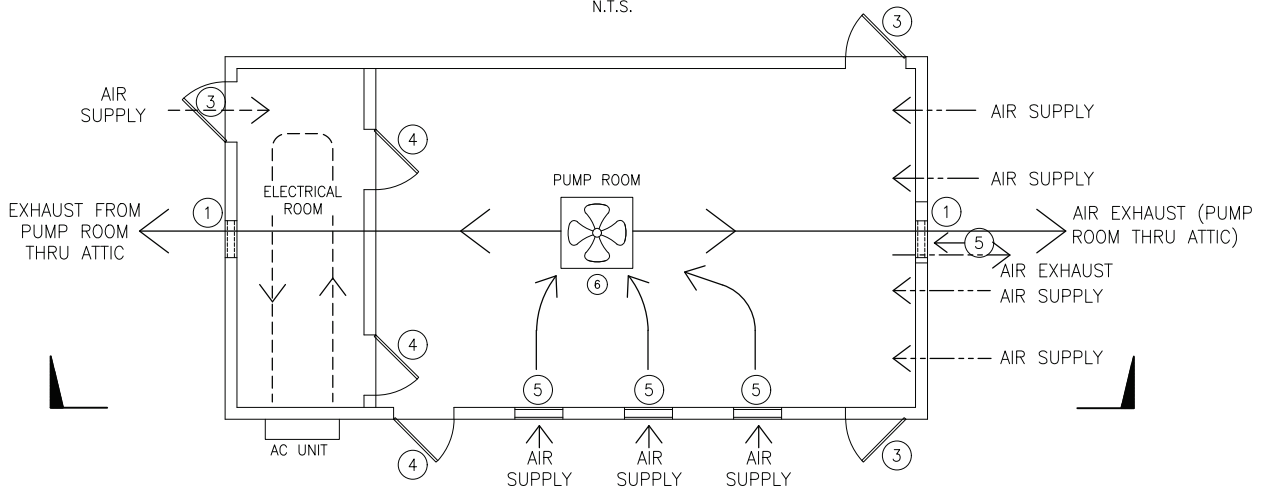

PLAN
N.T.S.

AIR FLOW SCHEMATIC

SCHEDULE

- (1) LOUVERED GATE VENT IN ATTIC.
- (2) AC CONTROLLED ELECTRICAL ROOM.
- (3) LOUVERED DOOR.
- (4) NON LOUVERED DOOR.
- (5) ACOUSTICAL LOUVERED VENT IN WALL.
- (6) VENT THRU CEILING TO ATTIC W/ ATTIC FAN (RATED 700 CFM).

NOTE:

Two isolated air systems shown in schematic.

----- System 1 Electrical Room

————— System 2 Pump Room

APPROVED BY:
GSWC STANDARDS COMMITTEE

Alison Sweet

EDC MANAGER

6/15/26
DATE



Golden State
Water Company

A Subsidiary of American States Water Company

TITLE:

**PUMP STATION
AIR FLOW SCHEMATIC**

SCALE:	DATE:	REV	STANDARD DWG NO.
NONE	07/31/23	2024	PS-15

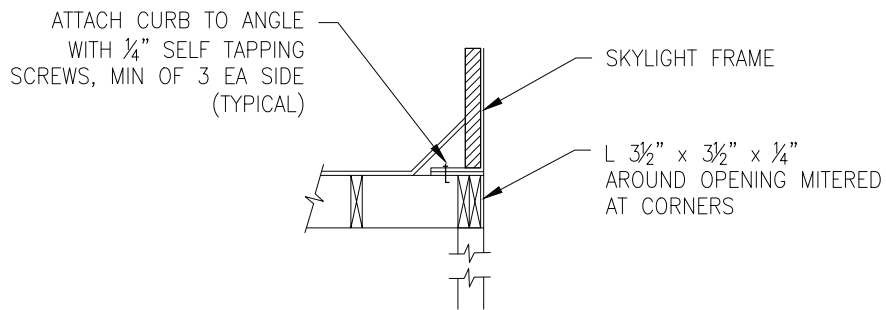
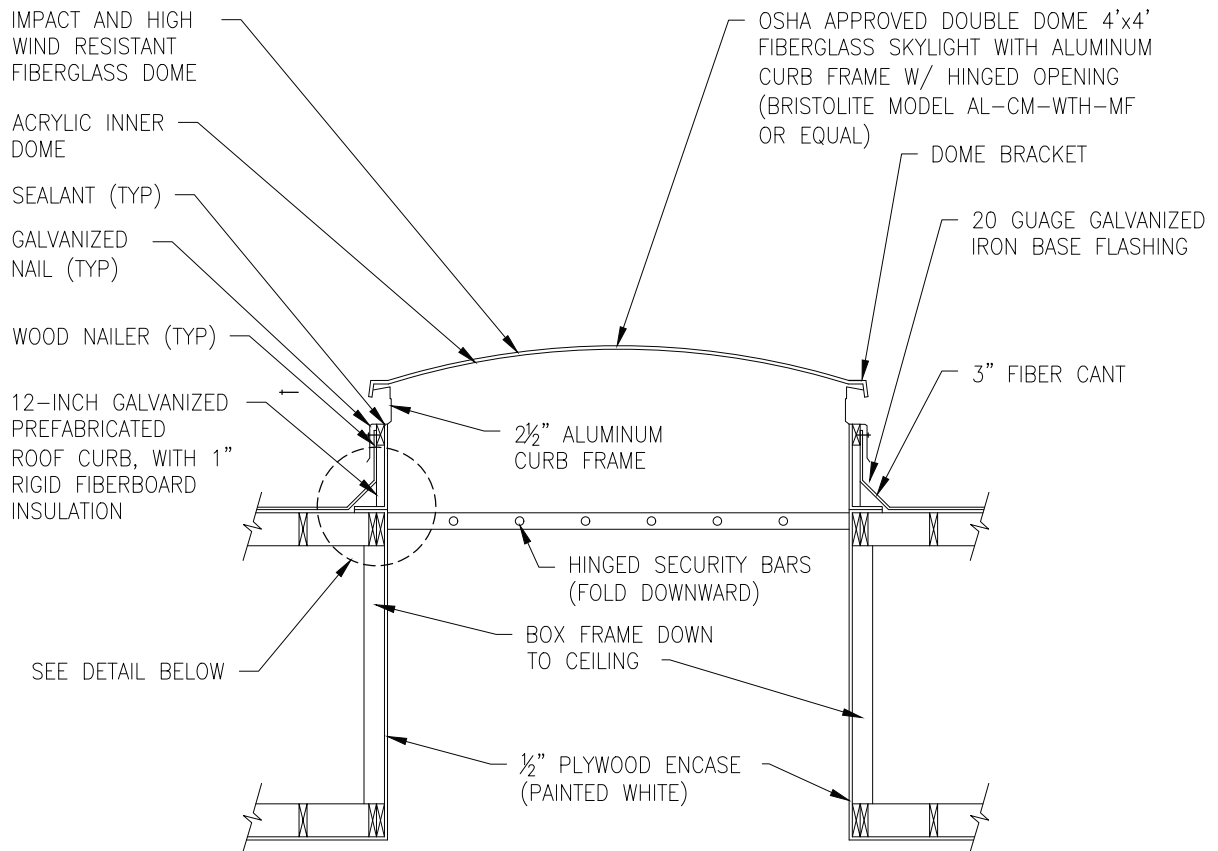

DETAIL
N.T.S.

SKYLIGHT AND ENCLOSURE
N.T.S.

NOTES:

1. Installation of skylight to be per manufacturer's requirements.
2. Coordinate with roofing contractor to ensure a weatherproof installation.

APPROVED BY:
GSWC STANDARDS COMMITTEE

Alison Sweet

EDC MANAGER

6/15/26
DATE



Golden State
Water Company

A Subsidiary of American States Water Company

TITLE:

**4' SQUARE SKYLIGHT
AND ENCLOSURE**

SCALE:
NONE

DATE:
07/31/23

REV
2024

STANDARD DWG NO.
PS-16A

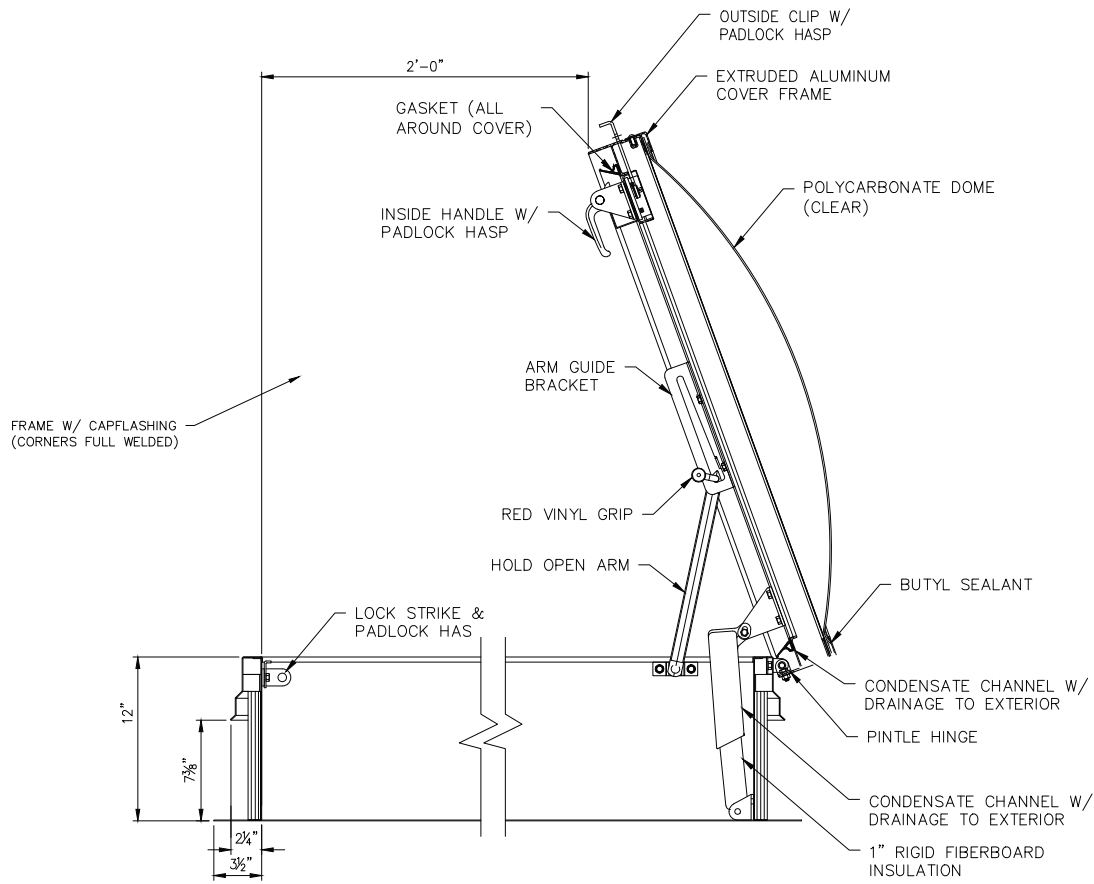
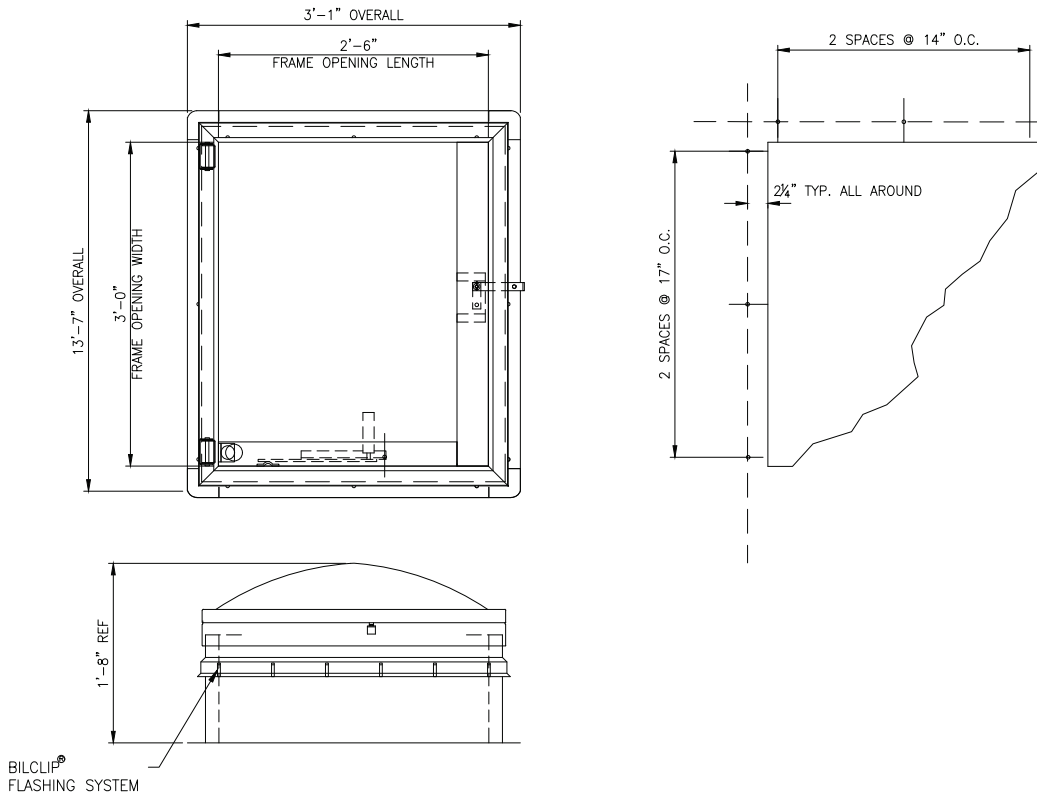

2'-6"x3'-0" OPENING SKYLIGHT AND ENCLOSURE
N.T.S.

APPROVED BY:
GSWC STANDARDS COMMITTEE

Alison Sweet

EDC MANAGER

6/15/26
DATE



Golden State
Water Company

A Subsidiary of American States Water Company

TITLE:

**2'-6" x 3'-0" OPENING
SKYLIGHT AND ENCLOSURE**

SCALE:
NONE

DATE:
07/31/23

REV
2024

STANDARD DWG NO.
PS-16B

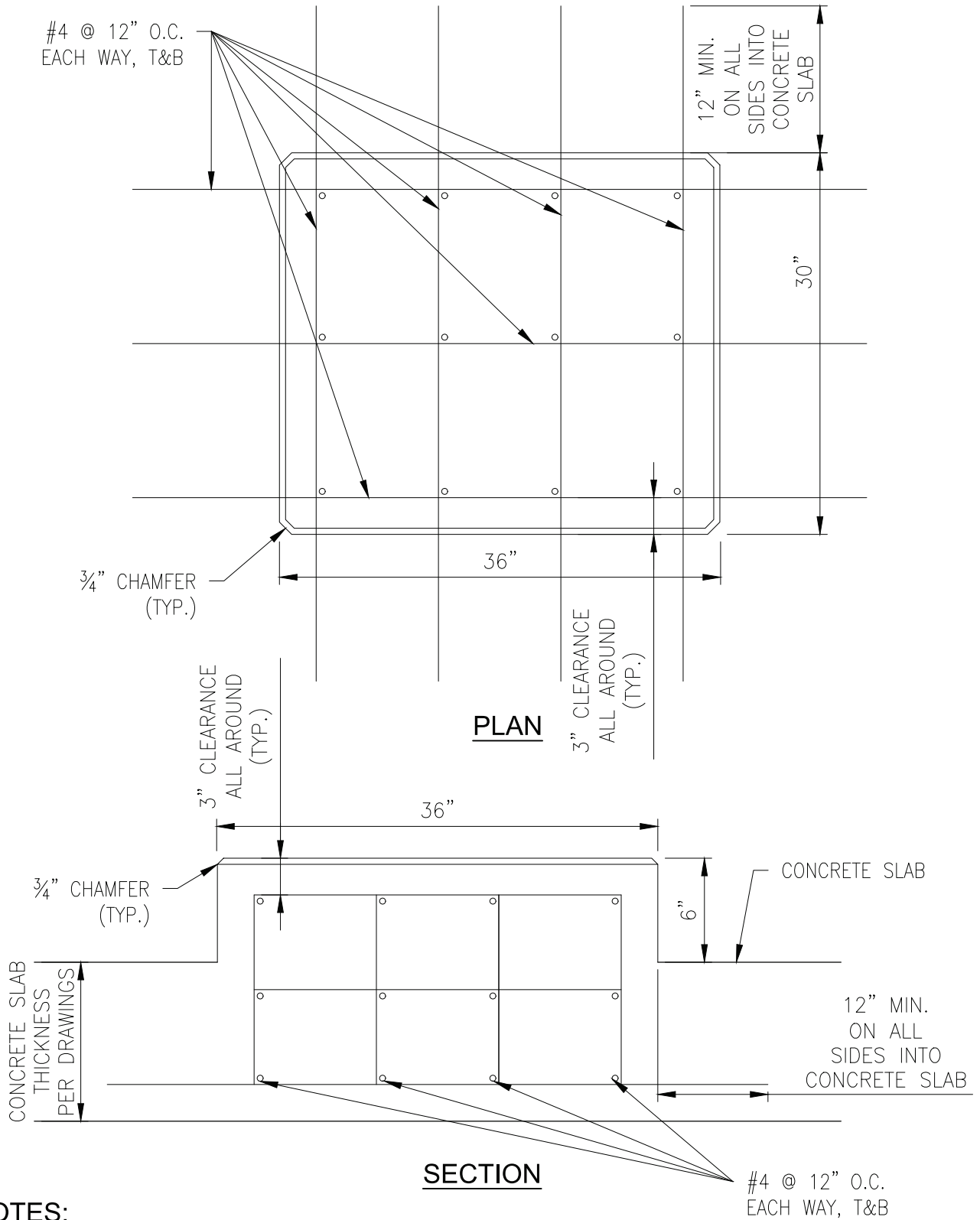

NOTES:

1. SPACING FOR BOTH HORIZONTAL AND VERTICAL REBAR SHALL BE ADJUSTED AS NEEDED TO MAKE EQUAL DISTANCE SPACING. MAXIMUM SPACING SHALL BE 12" O.C.
2. LOCATION OF PUMP ANCHOR BOLTS TO BE DETERMINED IN THE FIELD BY CONTRACTOR.

APPROVED BY:
GSWC STANDARDS COMMITTEE

Alison Sweet

EDC MANAGER

6/15/26
DATE



Golden State
Water Company

A Subsidiary of American States Water Company

TITLE:

CONCRETE PUMP BASE PEDESTAL
IN DIRT OR AC PAVEMENT
DETAIL

SCALE:
NONE

DATE:
04/17/26

REV
2026

STANDARD DWG NO.
PS-17A

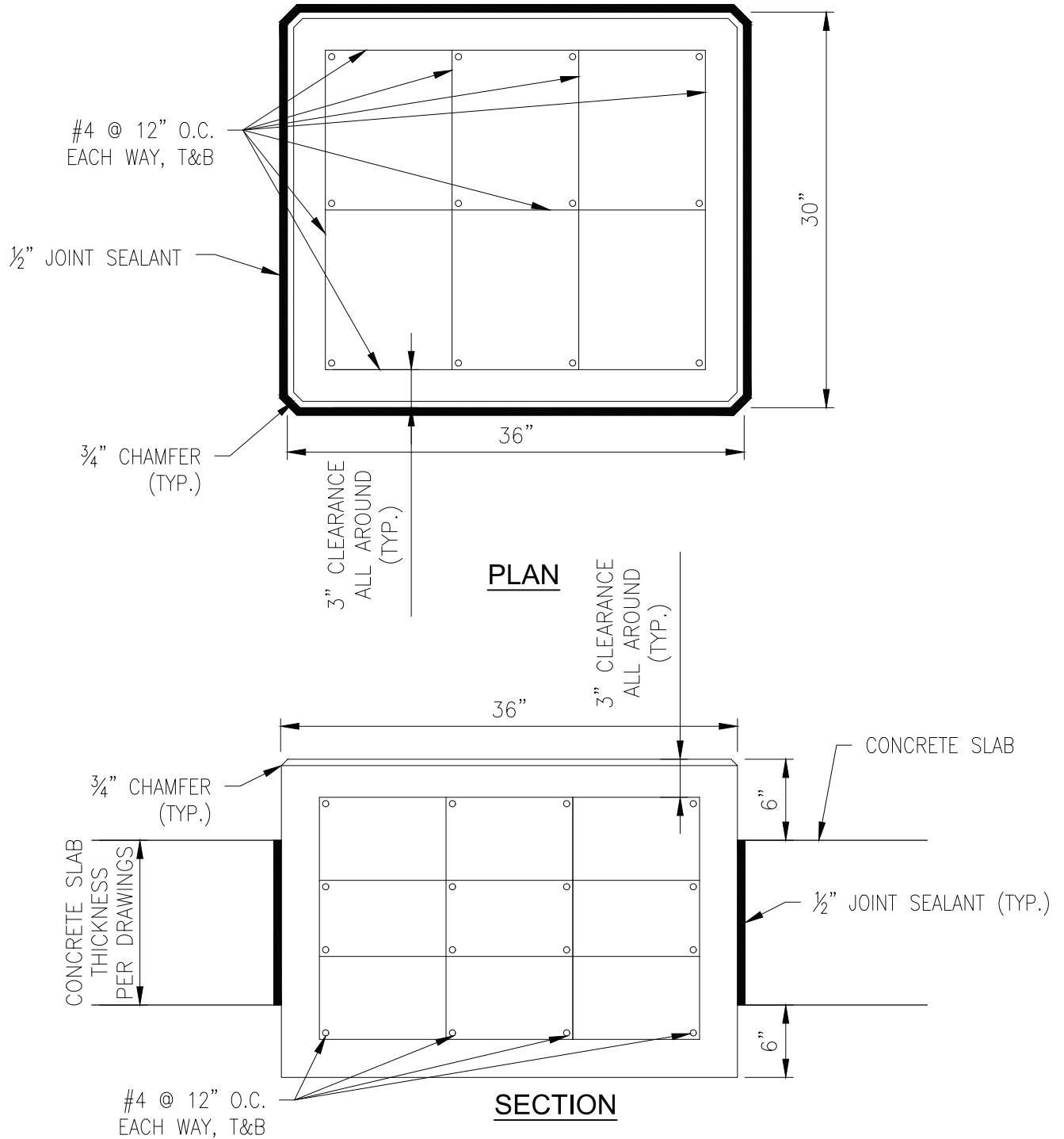

NOTES:

1. SPACING FOR BOTH HORIZONTAL AND VERTICAL REBAR SHALL BE ADJUSTED AS NEEDED TO MAKE EQUAL DISTANCE SPACING. MAXIMUM SPACING SHALL BE 12" O.C.
2. LOCATION OF PUMP ANCHOR BOLTS TO BE DETERMINED IN THE FIELD BY CONTRACTOR.

APPROVED BY:
GSWC STANDARDS COMMITTEE

Alison Sweet

EDC MANAGER

6/15/26
DATE



Golden State
Water Company

A Subsidiary of American States Water Company

TITLE:

CONCRETE PUMP BASE PEDESTAL
IN CONCRETE FLOOR SLAB
DETAIL

SCALE:
NONE

DATE:
04/17/26

REV
2026

STANDARD DWG NO.
PS-17B

Section 4

Wells

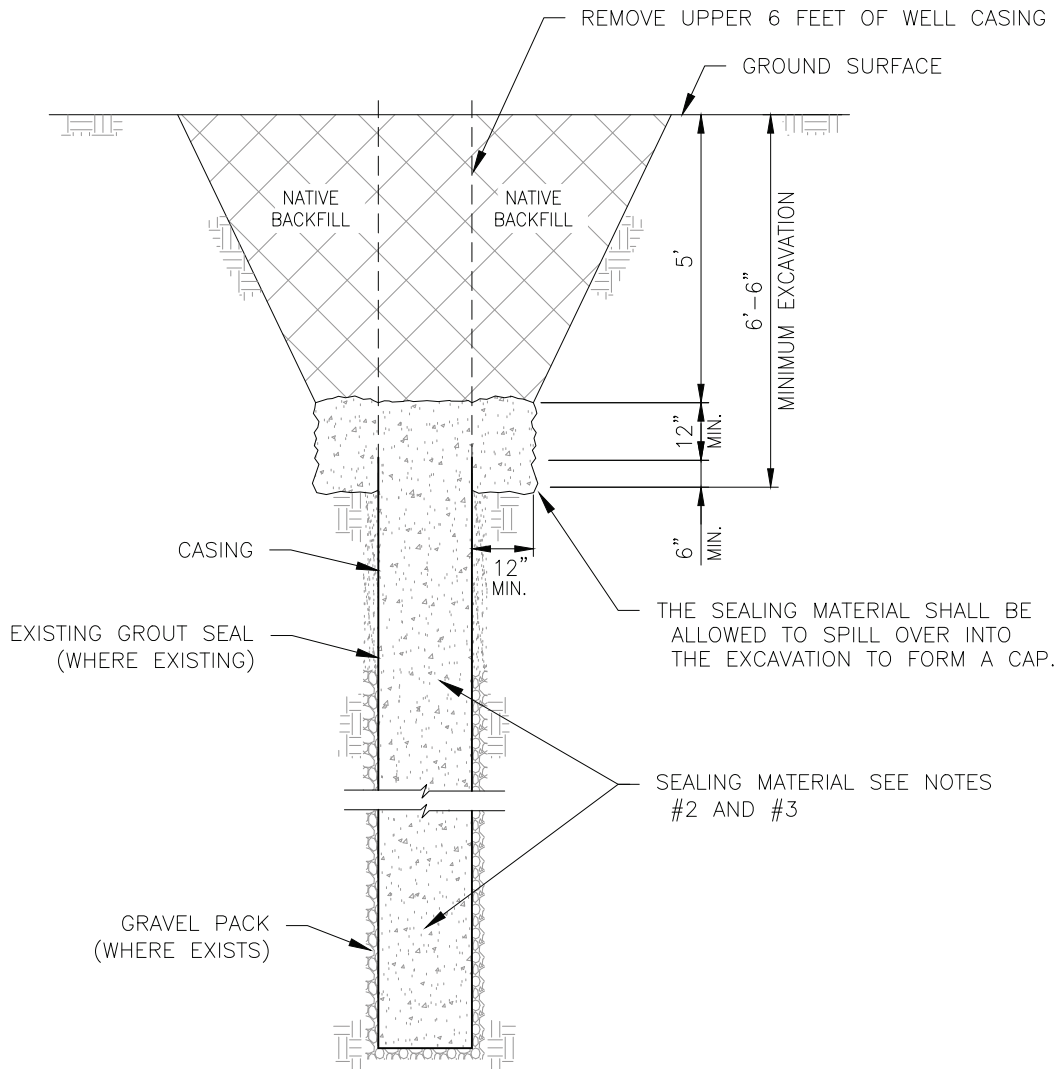

NOTES:

1. The well shall be cleaned, as needed, so that all undesirable materials, including obstructions to filling and sealing, sediment, debris, oil from oil-lubricated pumps, or pollutants and contaminants that could interfere with well destruction are removed for disposal.
2. Conditions may require that the casing be perforated using a millsknife or explosive charges prior to placement of sealing material.
3. Unless specifically described in the specifications, the sealing material shall be mixed at a ratio of not more than 188 pounds of sand to one 94 pound sack of portland cement (2 parts sand to 1 part cement, by weight) and about 7 gallons of clean water, where type I or type II portland cement is used. This is equivalent to a "10.3 sack mix". Less water shall be used if less sand than 2 parts sand per 1 part cement by weight is used. Additional water may be required when special additives, such as bentonite, or "accelerators" or "retardants" are used.
4. Sealing material shall be poured utilizing a tremie.
5. Backfill and compact the excavation only after sufficient time has been allowed for sealing material to set.
6. Each well destruction project is unique and requires specific approval and permits from the local jurisdictional agency.
7. Coordinate all well destruction work with the Water Resources group for current plans and specifications.

APPROVED BY:
GSWC STANDARDS COMMITTEE

Alison Sweet

EDC MANAGER

6/15/26
DATE



Golden State
Water Company

A Subsidiary of American States Water Company

TITLE:

WATER WELL DESTRUCTION

SCALE:
NONE

DATE:
07/31/23

REV
2024

STANDARD DWG NO.
W-1

NOTES:

1. Minimum lot size is 80'x100'(100'x100' is preferred).
2. Property is fenced on property line. Vehicle gate location will depend on lot line set back from curb and gutter to allow 20' drive-in from curb to fence.
3. A man-gate should be installed near vehicle gate.
4. Paving as shown. Alternative paving at least to chemical building.
5. Lot should drain to street. Adjust lot elevations as needed.
6. 50' clearance to property lines required for sanitary control.
7. Dimensions, locations and drainage shall be modified for each specific project.

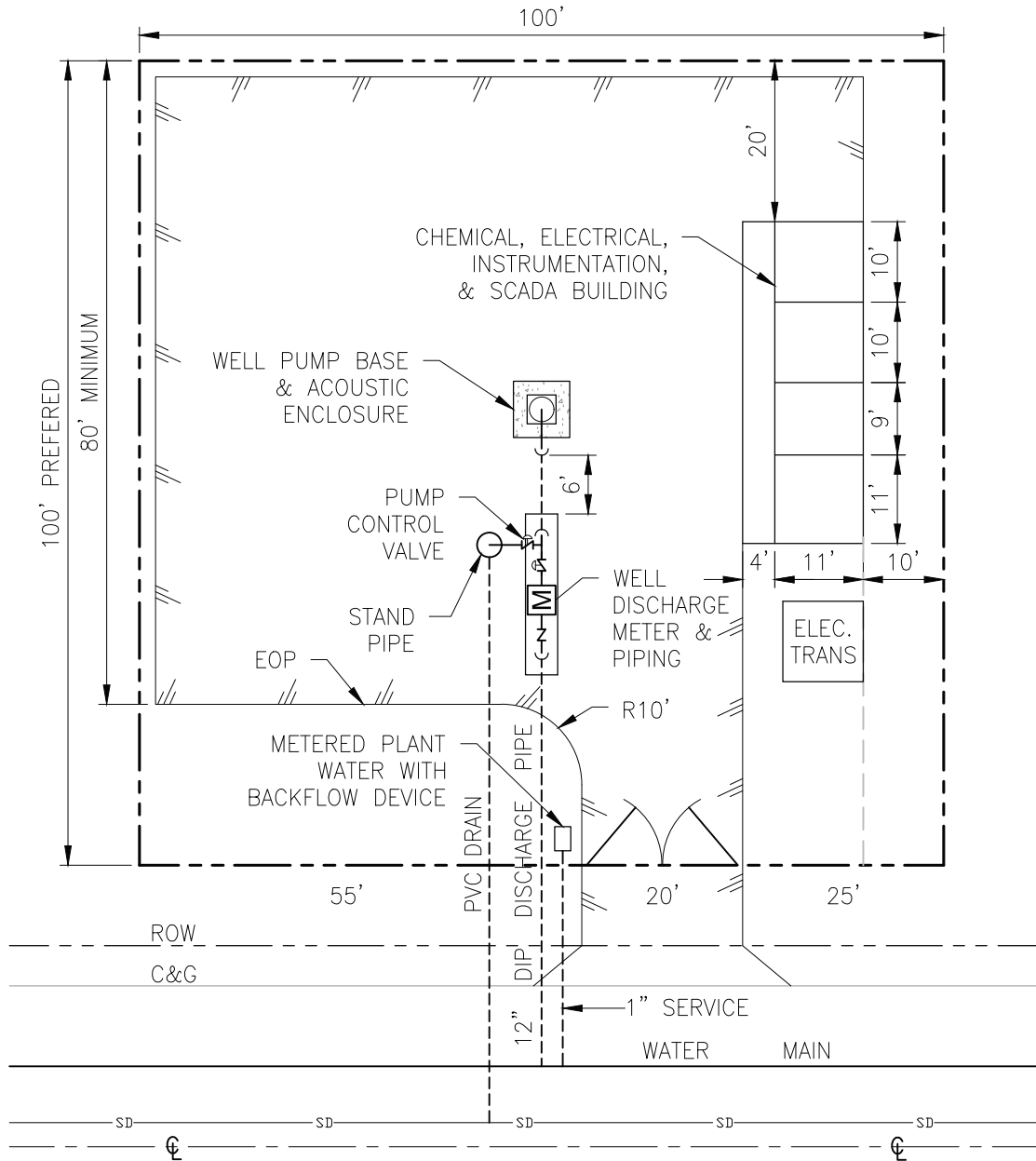

APPROVED BY:
GSWC STANDARDS COMMITTEE

Alison Sweet

EDC MANAGER

6/15/26
DATE



Golden State
Water Company

A Subsidiary of American States Water Company

TITLE:

TYPICAL WELL SITE PLAN
AND DIMENSIONS

SCALE:
NONE

DATE:
05/05/26

REV
2026

STANDARD DWG NO.
W-2

Anticipated Well Capacity	Upper Borehole Dia	Conductor Casing Dia	Well Borehole Dia	Well Casing Dia	Pump Column	Well Pump Base
Up to 1,000 gpm	42"	36"	28"	14"	6"	5' sq
1,000 to 3,000 gpm	48"	42"	32"	18"	8"	7' sq

NOTE:

1. Depths of louvered and blank casing will be determined for each well drilling project based on hydrogeologic conditions.
2. Each well destruction project is unique and requires specific approval and permits from the local jurisdictional agency.

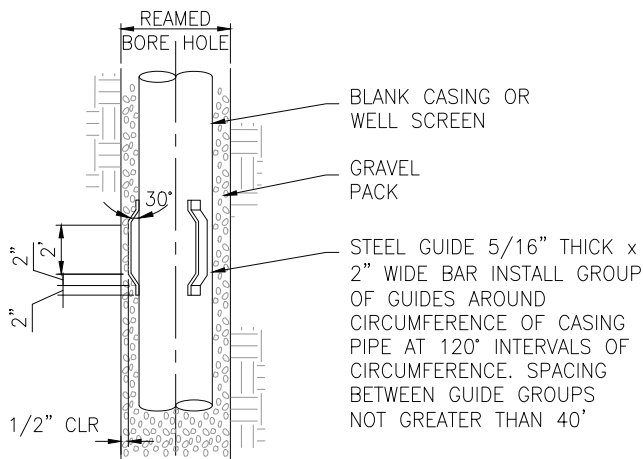

TYPICAL WELD-ON TYPE CASING CENTRALIZER
N.T.S.

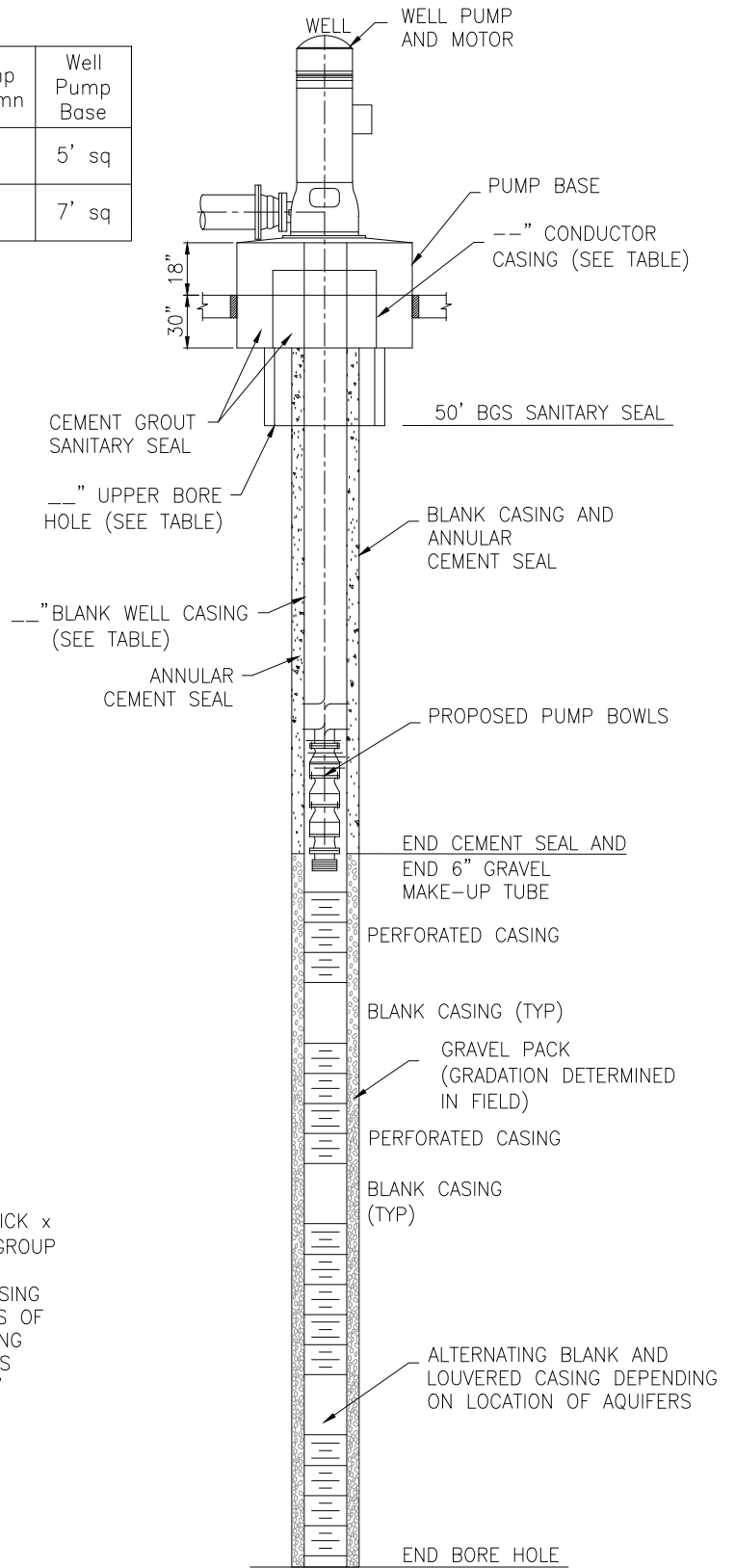

TYPICAL WELL CROSS SECTION
N.T.S.

APPROVED BY:
GSWC STANDARDS COMMITTEE

Alison Sweet

EDC MANAGER

6/15/26
DATE



Golden State
Water Company

A Subsidiary of American States Water Company

TITLE:

TYPICAL WELL CONSTRUCTION
CROSS SECTION

SCALE:	DATE:	REV	STANDARD DWG NO.
NONE	05/05/26	2026	W-3

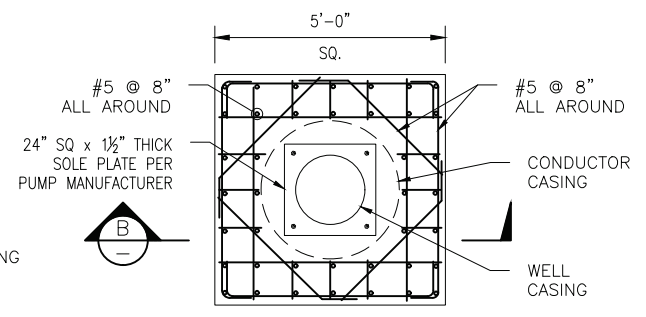
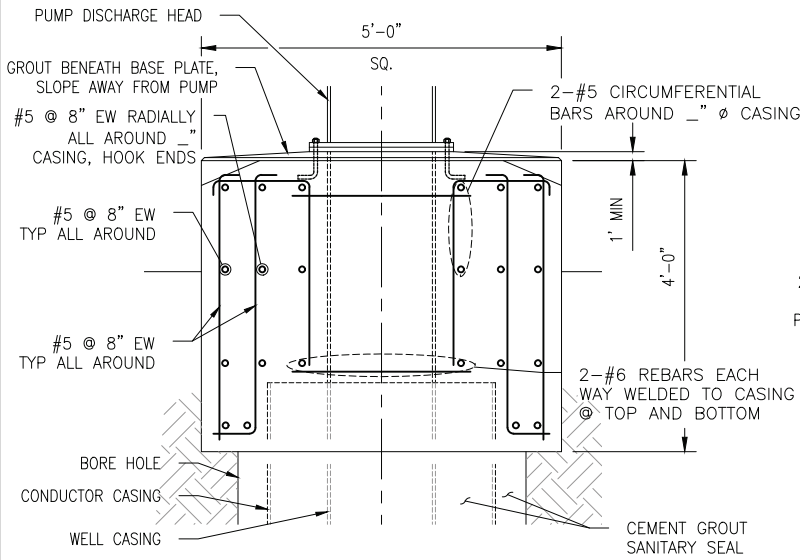
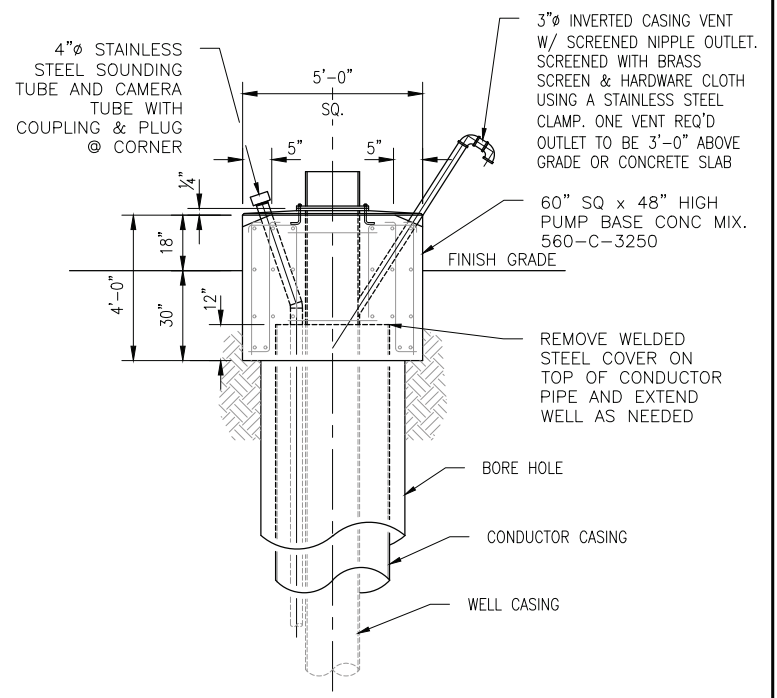
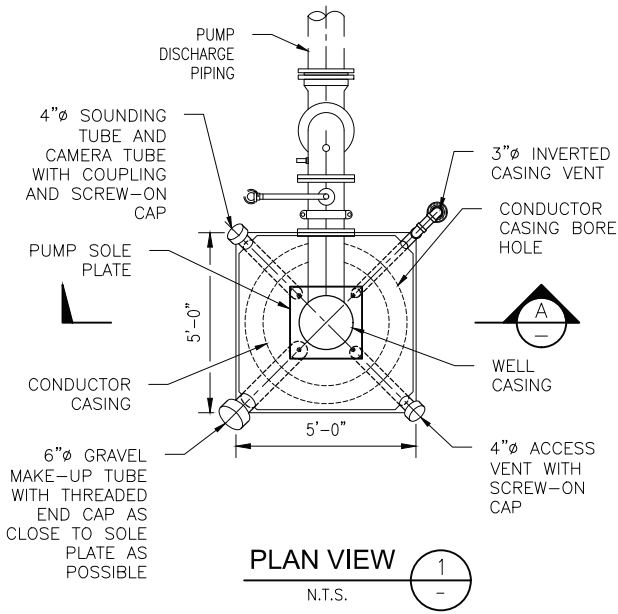

WELL PUMP BASE REBAR LAYOUT 2
N.T.S.

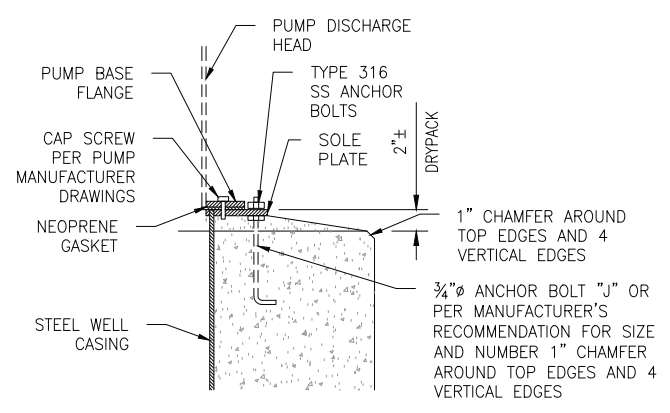

PUMP ANCHOR 3
N.T.S.

NOTES:

1. Wellhead mating flange (sole plate) threaded flange bolt holes. Weld flange to well casing. Recess the bolt area in concrete underside of the flange to accommodate bolt run through.
2. Camera tube, sounding tube, gravel tube and access vent to be located as close to vertical as possible through the top of the base and still avoid pump sole plate.
3. 1" chamfer on all edges.

APPROVED BY:
GSWC STANDARDS COMMITTEE
Alison Sweet
EDC MANAGER
6/15/26
DATE



TITLE: WELL PUMP BASE AND PUMP CONNECTION (UP TO 1,000 GPM)			
SCALE: NONE	DATE: 07/31/23	REV 2024	STANDARD DWG NO. W-4A

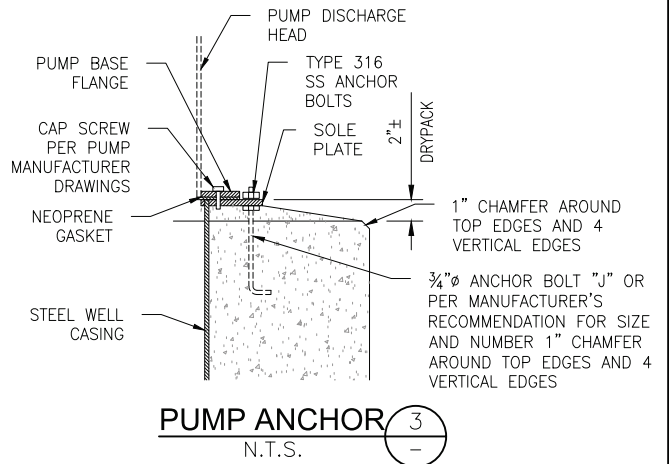
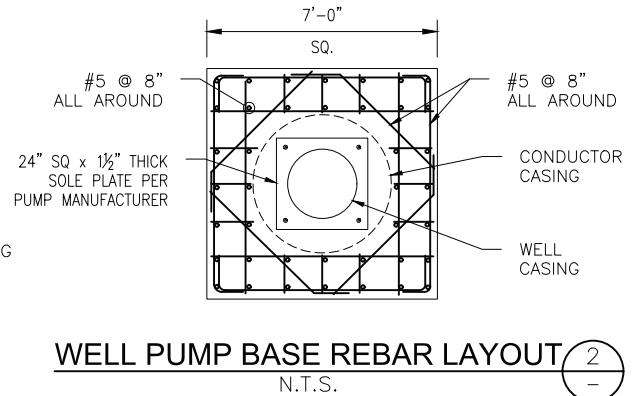
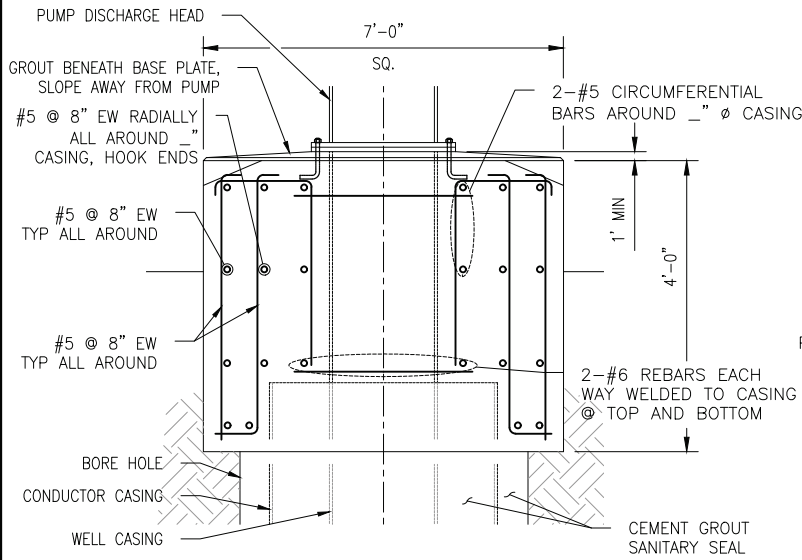
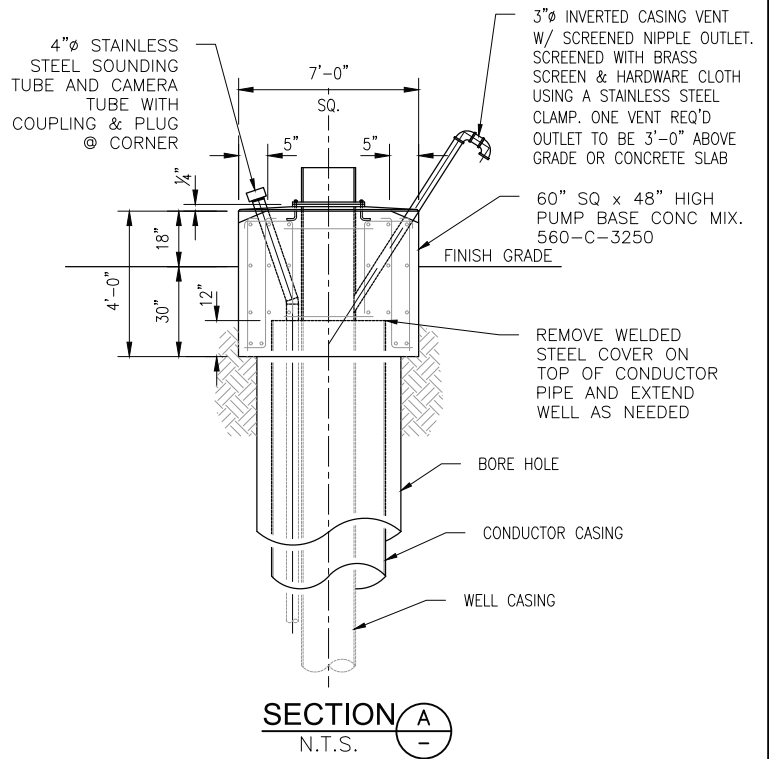
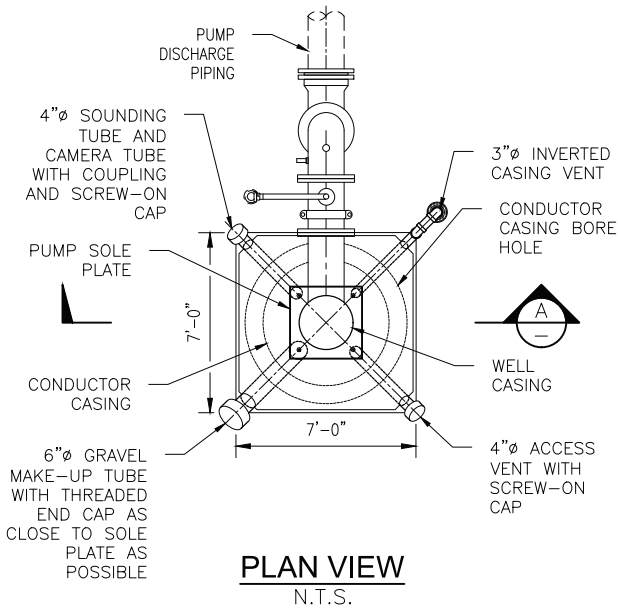

NOTES:

1. Wellhead mating flange (sole plate) threaded flange bolt holes. Weld flange to well casing. Recess the bolt area in concrete underside of the flange to accommodate bolt run through.
2. Camera tube, sounding tube, gravel tube and access vent to be located as close to vertical as possible through the top of the base and still avoid pump sole plate.
3. 1" chamfer on all edges.

APPROVED BY:
GSWC STANDARDS COMMITTEE

Alison Sweet

EDC MANAGER

6/15/26
DATE



Golden State
Water Company

A Subsidiary of American States Water Company

TITLE:

WELL PUMP BASE AND PUMP CONNECTION
(GREATER THAN 1,000 GPM)

SCALE:	DATE:	REV	STANDARD DWG NO.
NONE	07/31/23	2024	W-4B

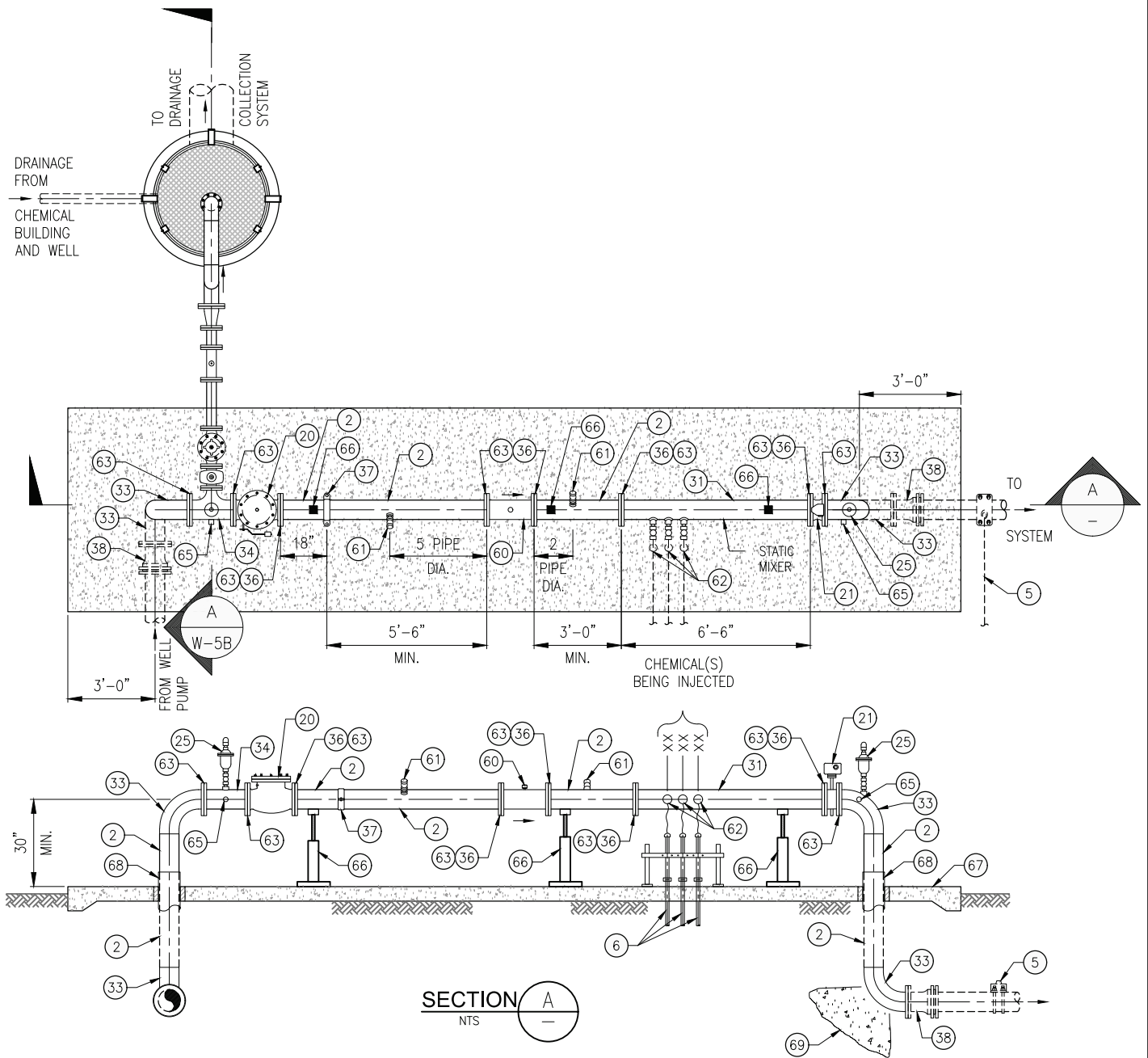

DESIGN NOTES:

1. Pipe and meter size shall produce velocity less than 10 fps.
2. Testing ports shall be 5 pipe diameters upstream and 2 pipe diameters downstream of the meter with no bends or pipe breaks that could cause turbulence.
3. All steel pipe shall be epoxy lined & painted after fabrication.
4. Pipe sizes shown are for 8-inch diameter pipe. Adjust dimensions as needed for different pipe sizes.
5. Flanged connections between ductile iron pipe and valves and steel pipe shall include an insulating gasket to electrically isolate each metal surface from the other.

APPROVED BY:
GSWC STANDARDS COMMITTEE

Alison Sweet

EDC MANAGER

6/15/26
DATE



Golden State
Water Company

A Subsidiary of American States Water Company

TITLE:

WELL DISCHARGE PIPE

SCALE:
NONE

DATE:
04/20/26

REV
2026

STANDARD DWG NO.
W-5A

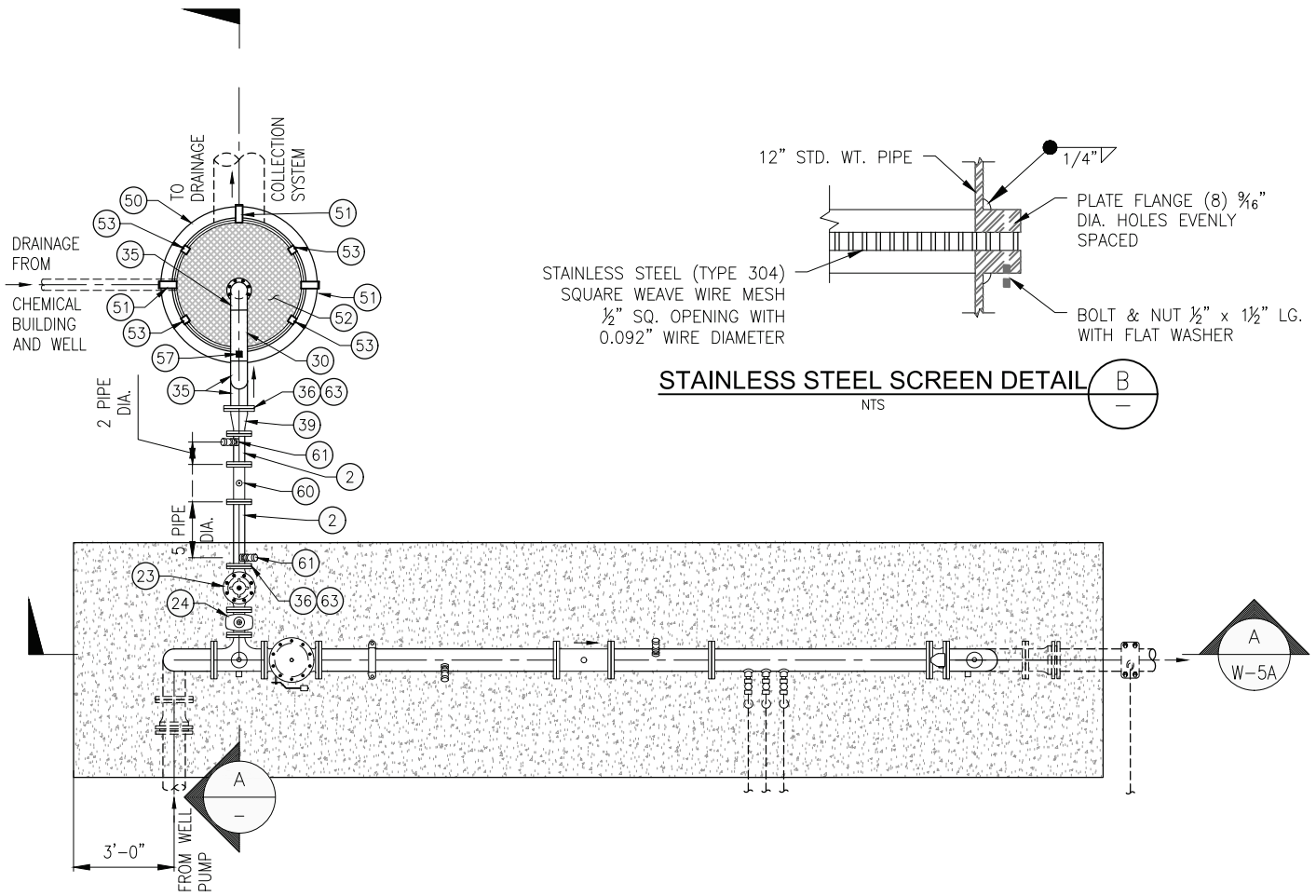

DESIGN NOTES:

1. Testing ports shall be 5 pipe diameters upstream and 2 pipe diameters downstream of the meter with no bends or pipe breaks that could cause turbulence.
2. All steel pipe shall be epoxy lined & painted after fabrication.
3. Pipe sizes shown are for 8-inch diameter well discharge pipe. Adjust dimensions as needed for different pipe sizes.
4. Flanged connections between ductile iron pipe and valves and steel pipe shall include an insulating gasket to electrically isolate each metal surface from the other.

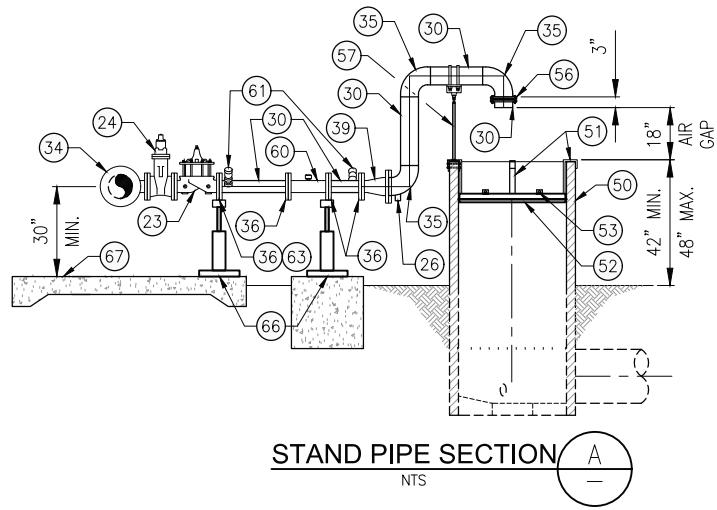

APPROVED BY:
GSWC STANDARDS COMMITTEE

Alison Sweet
EDC MANAGER

6/15/26
DATE



TITLE: WELL FLUSH PIPE			
SCALE: NONE	DATE: 04/20/26	REV 2026	STANDARD DWG NO. W-5B

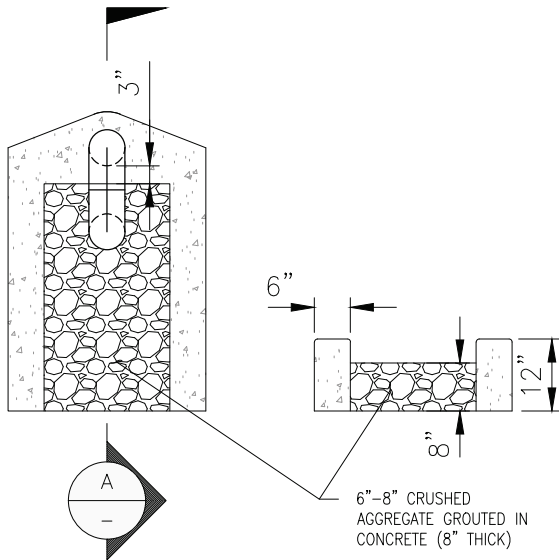

CONCRETE SPLASH PAD
N.T.S.

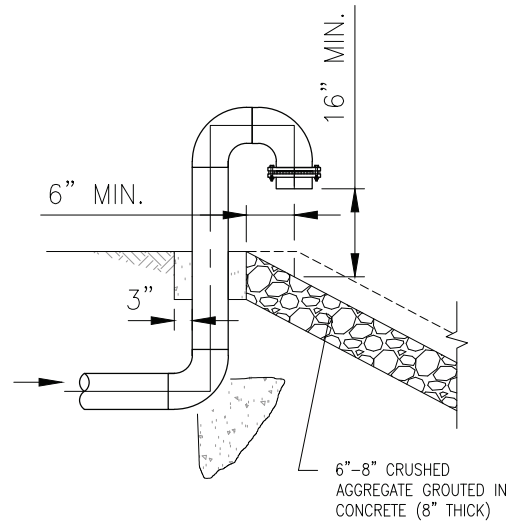

**CONCRETE SPLASH PAD
STAND PIPE SECTION** (A)
NTS

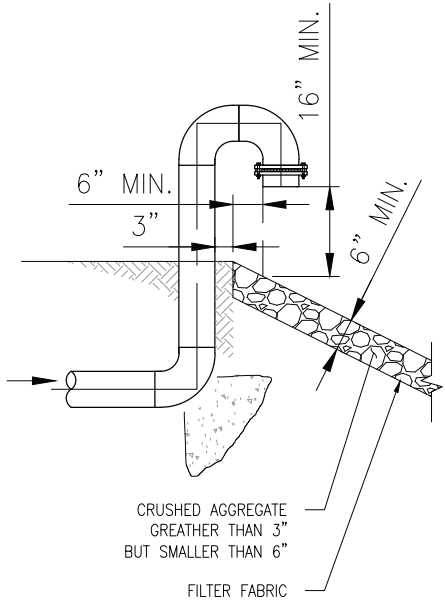

BELOW GROUND WELL FLUSH PIPE
N.T.S.

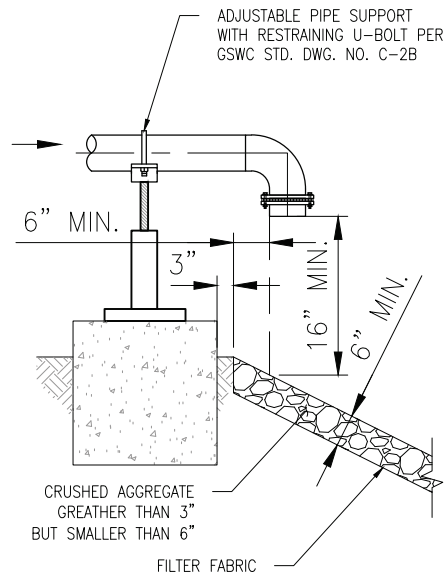

ABOVE GROUND WELL FLUSH PIPE
N.T.S.

DESIGN NOTES:

1. All steel pipe shall be epoxy lined & painted after fabrication.
2. Pipe sizes shown are for 6-inch diameter pipe. Adjust dimensions as needed for different pipe sizes. Air gap shall be set up in accordance with California Plumbing Code requirements, providing a minimum vertical separation of at least two (2) times the effective diameter of the supply pipe, but no less than one (1) inch.

APPROVED BY:
GSWC STANDARDS COMMITTEE

Alison Sweet

EDC MANAGER

6/15/26
DATE



Golden State
Water Company

A Subsidiary of American States Water Company

TITLE:

WELL FLUSH PIPE
DISCHARGE TO OUTFALL

SCALE:	DATE:	REV	STANDARD DWG NO.
NONE	04/15/26	2026	W-5C

CONSTRUCTION NOTES

PIPE

- ①— INSTALL PVC DRAIN PIPE AND FITTINGS PER AWWA C-900, CL-235, DR-18 WITH TRENCH.
- ②— INSTALL STANDARD WEIGHT STEEL SPOOL (PExPE)
- ③— INSTALL PVC DRAIN PIPE AND FITTINGS PER AWWA C-900, CL-235, DR-18 WITH TRENCH.
- ④— INSTALL PVC DRAIN PIPE AND FITTINGS PER SCH 80 WITH TRENCH.
- ⑤— INSTALL 2" COPPER WATER SERVICE (PER STD. DWG. P-27) WITH APPROVED RP BACKFLOW ASSEMBLY (PER STD. DWG. P-35A) TO ANALYZER TAP AND WELL PUMP WITH WATER FLUSH MANIFOLD FOR STARTUP PRE-LUBRICATION WITH TRENCH.
- ⑥— INSTALL CHEMICAL CONVEYANCE TUBING IN 1½" PVC SCH-80 CONTAINMENT PIPE AND FITTINGS, WITH TRENCH.

VALVES

- ⑳— INSTALL SWING CHECK VALVE, FE (MUELLER MODEL A-2600-6-2)
- ㉑— INSTALL BUTTERFLY VALVE
- ㉓— INSTALL PUMP CONTROL VALVE (CLA-VAL MODEL 61-02)
- ㉔— INSTALL RW GATE VALVE
- ㉕— INSTALL 2" COMBINATION AIR VACUUM RELEASE VALVE ASSEMBLY.
- ㉖— INSTALL 1' THREAD-O-LET AND 1"x½" BUSHING WITH A RAINBIRD DRAIN VALVE (PART NO 16AFDVC1)

FITTINGS

- ③①— INSTALL STEEL SPOOL (PExPE)
- ③②— INSTALL STEEL SPOOL (FExFE)
- ③③— INSTALL 90° DI BEND (MJxMJ)
- ③④— INSTALL 90° STEEL LONG RADIUS ELBOW (FExPE)
- ③⑤— INSTALL STEEL TEE (FExFExFE)
- ③⑥— INSTALL 90° STEEL SHORT RADIUS ELBOW (PExPE)
- ③⑦— INSTALL WELD ON FLANGE
- ③⑧— INSTALL VICTAULIC COUPLING
- ③⑨— INSTALL FLANGED x MJ ADAPTER (FULLY RESTRAINED)
- ④①— INSTALL REDUCER (FExFE)

STAND PIPE

- ⑤①— INSTALL 4' DIAMETER RCP STANDPIPE.
- ⑤②— INSTALL 2½"x2½"x2" WIDE X ⅜" GALVANIZED ANGLE FLAT IRON BAR. ANCHOR TO WALL W/ SS ¼" DIA. X 2" LONG THREADED ANGHOR BOLT, SS WASHER & NUT. DRILL & EPOXY ANCHOR TO RCP WALL ABOVE RING BAR (TAMPER PROOF TAB).
- ⑤③— INSTALL 1½" GALVANIZED FLAT STOCK WELDED GRATE. TACK WELD TO STEEL RING BAR W/DISSIMILAR WELD ROD.
- ⑤④— INSTALL 2"x⅜" GALVANIZED FLAT BAR HANGER, WELD TO RING BAR.
- ⑤⑤— INSTALL 1"x⅜" FLAT STEEL BAR COATED WITH POLYURETHANE SPRAY PAINT.
- ⑤⑥— INSTALL CONCRETE STAND PIPE BASE, CAST IN PLACE, Poured AGAINST UNDISTURBED SOIL. USE 3250 PSI CONCRETE
- ⑤⑦— INSTALL STAINLESS STEEL SCREEN.
- ⑤⑧— INSTALL ADJUSTABLE PIPE SUPPORT ON STANDPIPE.

SPECIALS

- ⑥①— INSTALL MAGMETER PER SPECIFICATIONS
- ⑥②— INSTALL WELDED 1" THREAD-O-LET, 1" CORPORATION STOP WITH 1" BRASS PLUG FOR METER TEST. SET AT 45° DOWN FROM TOP OF PIPE.
- ⑥③— INSTALL CHEMICAL INJECTION QUILL WITH PROTECTIVE CAGE.
- ⑥④— INSTALL FLANGE CONNECTION BETWEEN STEEL AND DIP WITH AN INSULATING GASKET.
- ⑥⑤— INSTALL PRESSURE TAP.
- ⑥⑥— INSTALL WATER QUALITY SAMPLE POINT.
- ⑥⑦— INSTALL ADJUSTABLE PIPE SUPPORT.
- ⑥⑧— INSTALL CONCRETE SLAB.
- ⑥⑨— INSTALL SEAL WITH NON-SHRINK GROUT, 2" AROUND PIPE OD. PENETRATE RCP STAND PIPE ABOVE CONCRETE BASE FOR DRAIN LINE CONNECTION.
- ⑦①— INSTALL THRUST BLOCK.
- ⑦②— INSTALL RTV SILICONE SEALANT
- ⑦③— INSTALL POLYETHYLENE TUBING THROUGH SLAB.

APPROVED BY:
GSWC STANDARDS COMMITTEE

Alison Sweet

EDC MANAGER

6/15/26
DATE



Golden State
Water Company

A Subsidiary of American States Water Company

TITLE:

WELL DISCHARGE PIPE
AND FLUSH PIPE

SCALE:	DATE:	REV	STANDARD DWG NO.
NONE	04/20/26	2026	W-5D

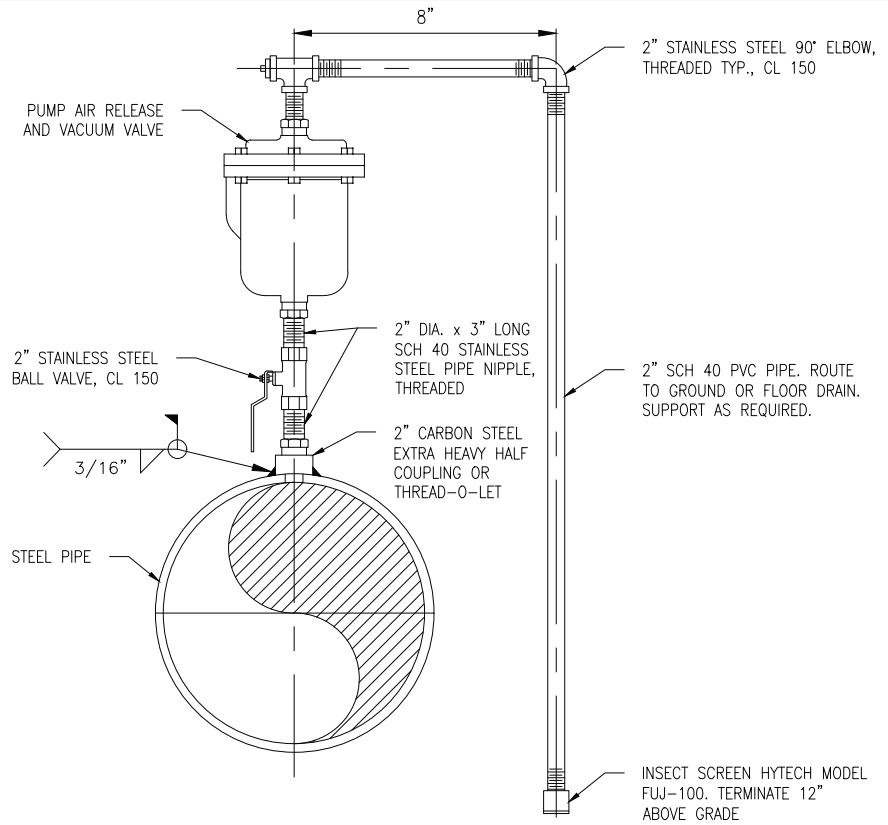

NOTES:

1. 2" A/V for 1,000 GPM well installation
2. 4" A/V for 1,500 GPM and above well installation

PUMP AIR RELEASE/VACUUM VALVE DETAIL

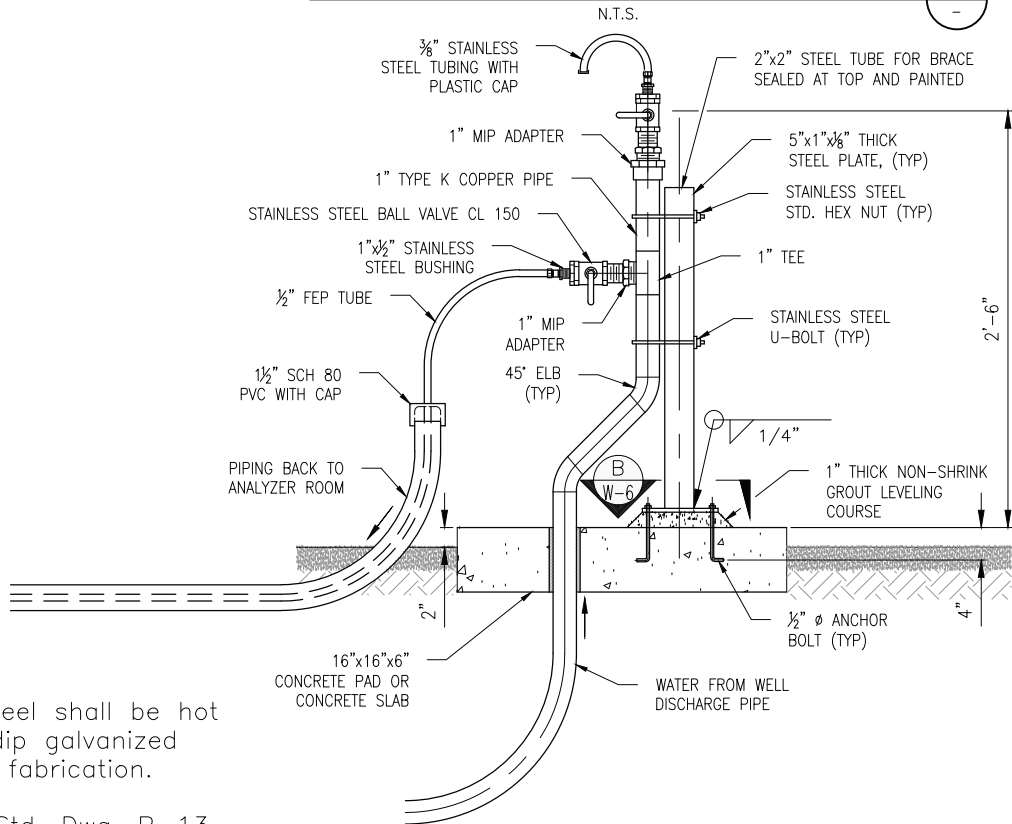

NOTES:

1. All steel shall be hot dip-dip galvanized after fabrication.
2. See Std. Dwg. P-13 for sampling enclosure.

ABOVE GROUND WATER QUALITY SAMPLING DETAIL

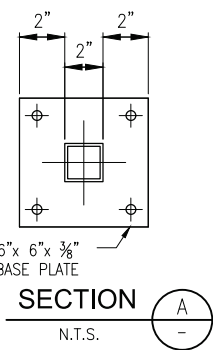

APPROVED BY:
GSWC STANDARDS COMMITTEE

Alison Sweet
EDC MANAGER

6/15/26
DATE



Golden State
Water Company

A Subsidiary of American States Water Company

TITLE:

**WATER QUALITY SAMPLING AND
AIR RELEASE &
VACUUM VALVE ASSEMBLY**

SCALE:	DATE:	REV	STANDARD DWG NO.
NONE	07/31/23	2024	W-6

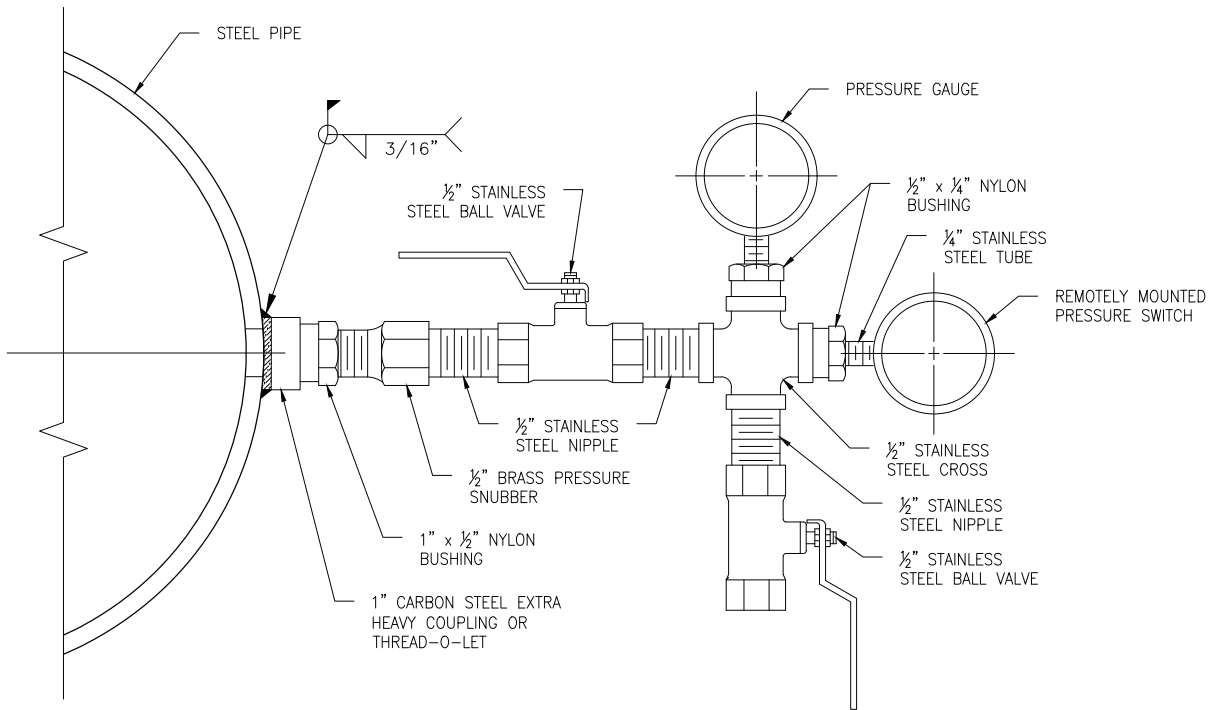

**PRESSURE GAGE AND
PRESSURE TRANSMITTER DETAIL**

N.T.S.

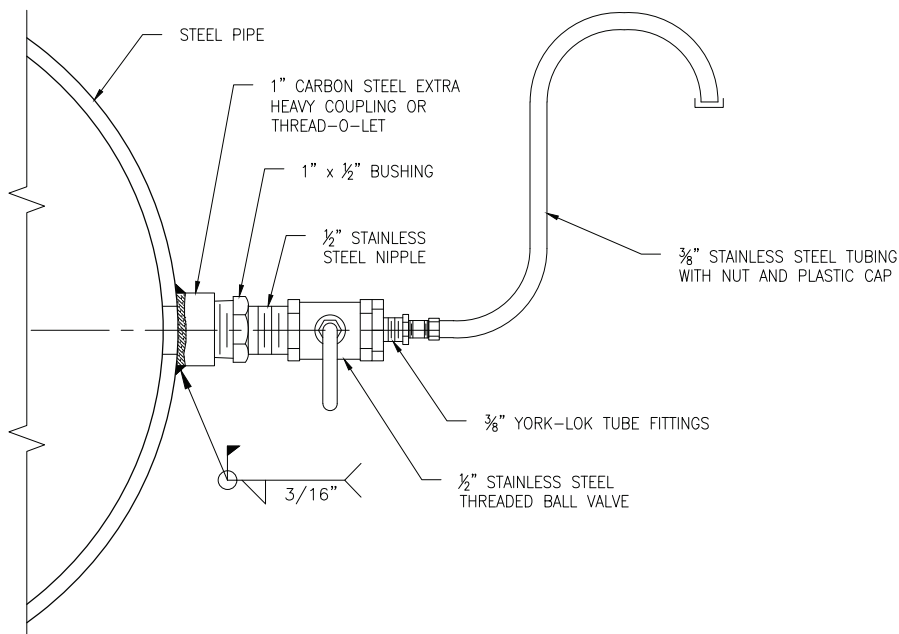

WATER QUALITY SAMPLING PORT DETAIL

N.T.S.



APPROVED BY:
GSWC STANDARDS COMMITTEE

Alison Sweet

EDC MANAGER

6/15/26
DATE



Golden State
Water Company

A Subsidiary of American States Water Company

TITLE:

**PRESSURE GAGE AND
WATER QUALITY SAMPLING PORT**

SCALE:	DATE:	REV	STANDARD DWG NO.
NONE	07/31/23	2024	W-7

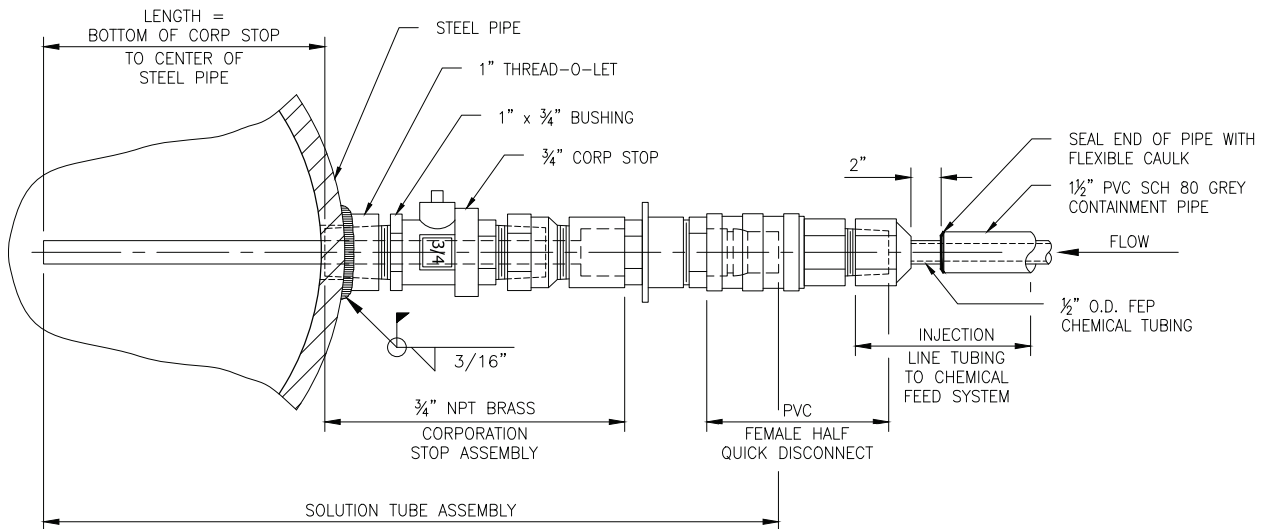

NOTE:

1. Injection assembly materials in contact with chemical shall be compatible with chemical being conveyed.
2. Injection quill shall have integral check valve.

CHEMICAL INJECTION QUILL DETAIL

N.T.S.

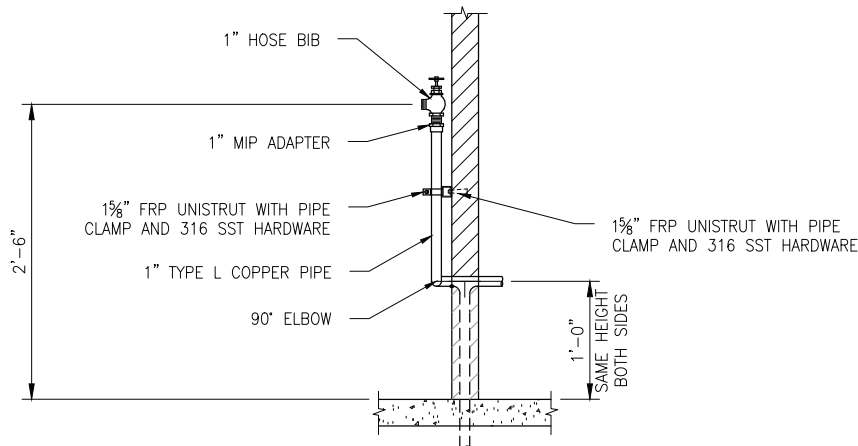

NOTE:

1. Install a vacuum breaker on each hose bib.

HOSE BIB DETAIL

N.T.S.



APPROVED BY:
GSWC STANDARDS COMMITTEE

Alison Sweet

EDC MANAGER

6/15/26
DATE



Golden State
Water Company

A Subsidiary of American States Water Company

TITLE:

**CHEMICAL INJECTION QUILL
AND HOSE BIB**

SCALE:
NONE

DATE:
07/31/23

REV
2024

STANDARD DWG NO.
W-8A

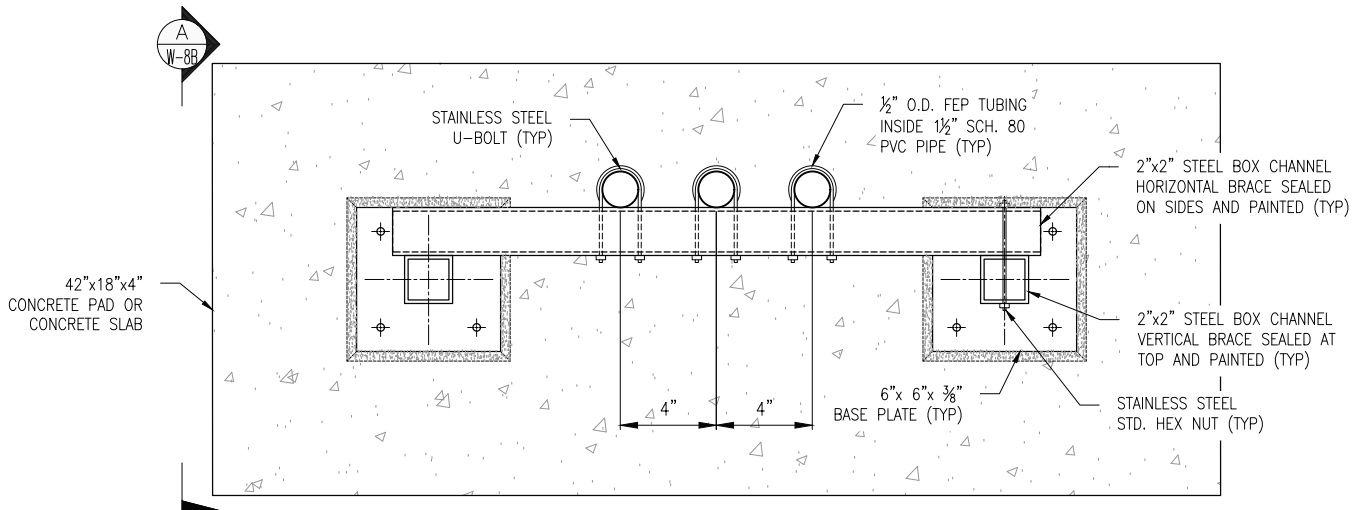

CHEMICAL INJECTION QUILL SUPPORT DETAIL (1)
N.T.S.

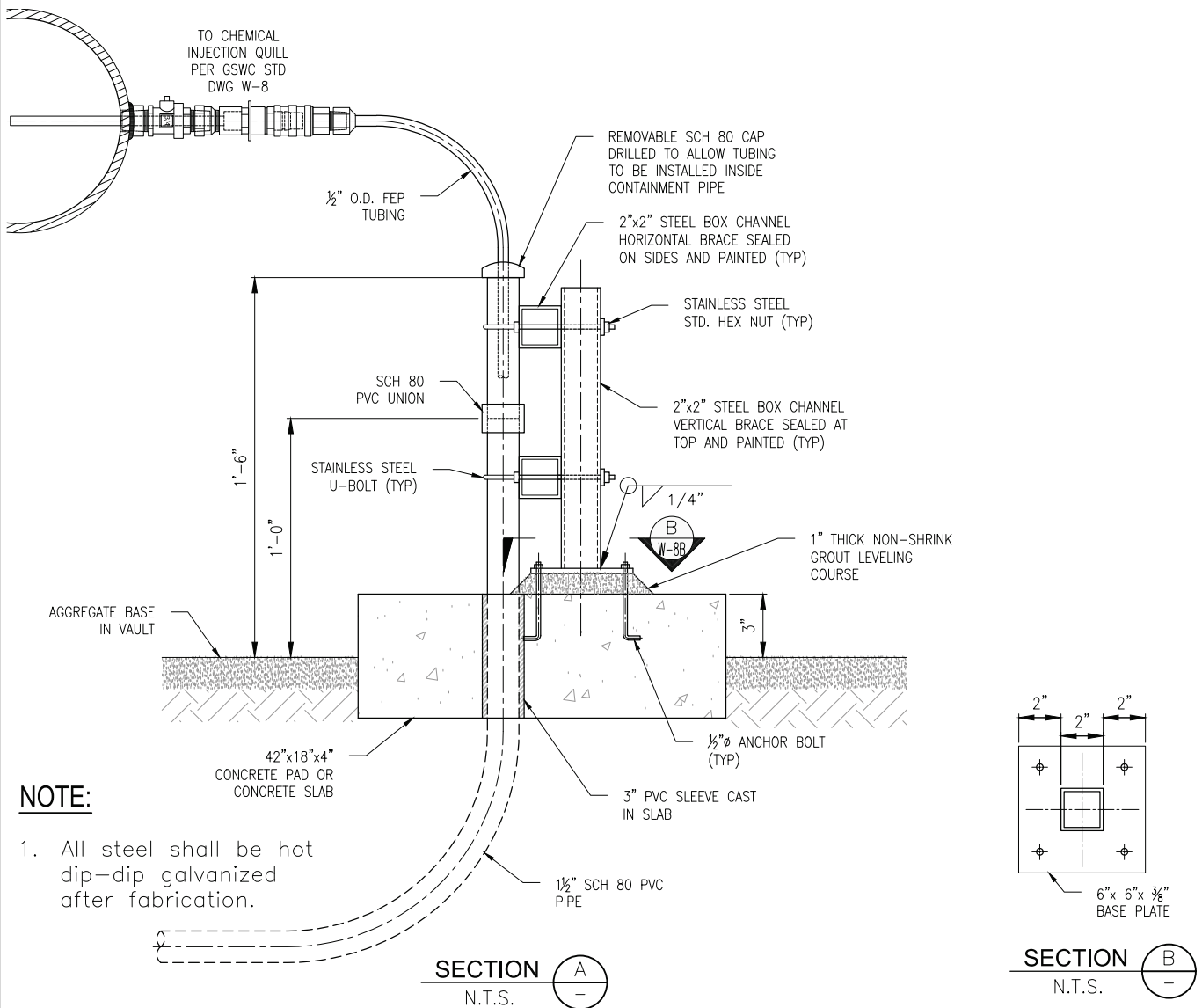

NOTE:

1. All steel shall be hot dip-dip galvanized after fabrication.

SECTION A
N.T.S.

SECTION B
N.T.S.

APPROVED BY:
GSWC STANDARDS COMMITTEE

Alison Sweet

EDC MANAGER

6/15/26
DATE



Golden State
Water Company

A Subsidiary of American States Water Company

TITLE:

**CHEMICAL INJECTION QUILL
SUPPORT**

SCALE:
NONE

DATE:
07/31/23

REV
2024

STANDARD DWG NO.
W-8B

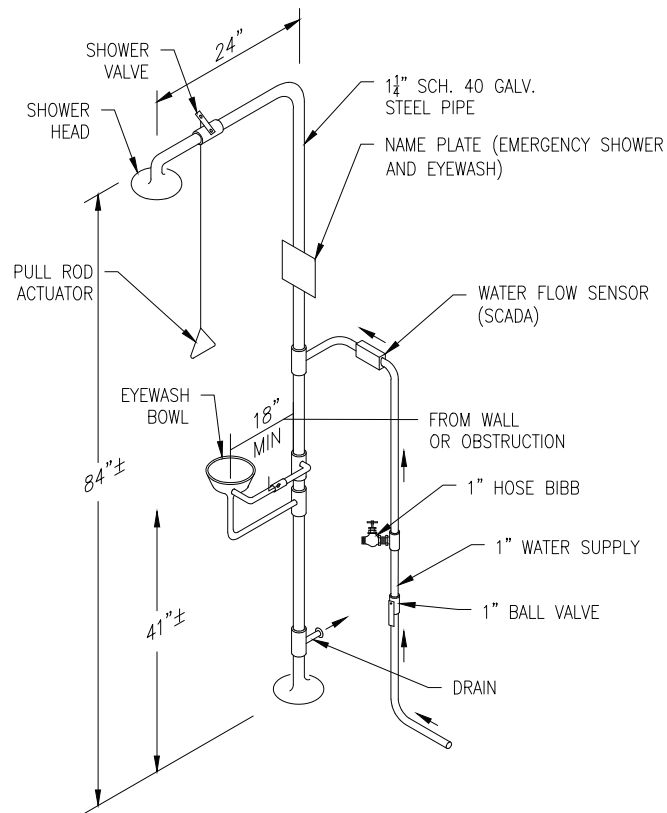

NOTE:

1. Vacuum breakers to be installed on all hose bibs.

APPROVED BY:
GSWC STANDARDS COMMITTEE

Alison Sweet

EDC MANAGER

6/15/26
DATE



Golden State
Water Company

A Subsidiary of American States Water Company

TITLE:

EMERGENCY EYEWASH & SHOWER

SCALE:
NONE

DATE:
05/05/26

REV
2026

STANDARD DWG NO.
W-9A

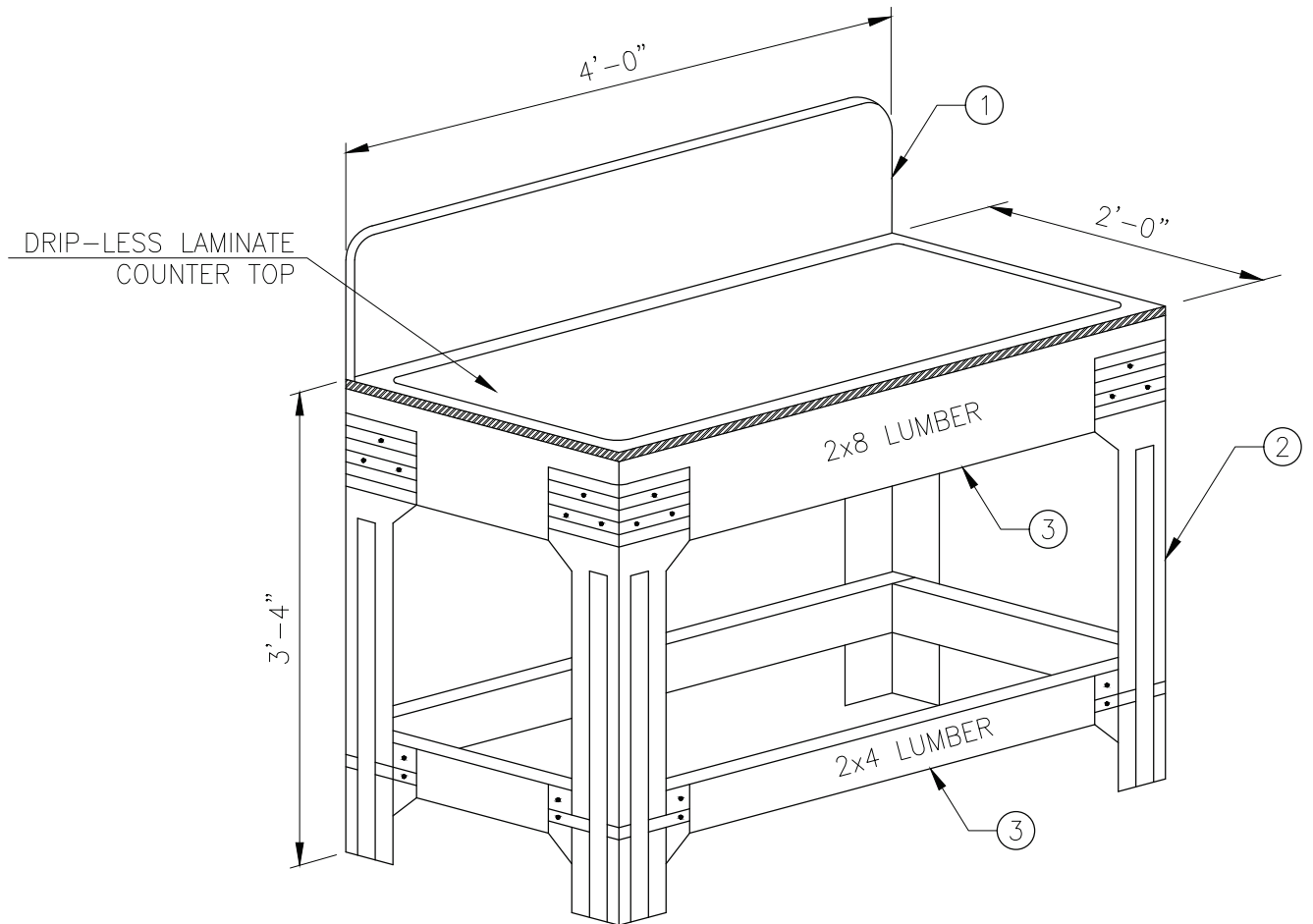

CONSTRUCTION NOTES:

- ① Laminate countertop with 12" high backsplash.
- ② Plastic resin workbench legs, 36" high, 2x4 Basics item no. 90158.
- ③ Plastic lumber
- ④ All exposed wood surfaces on bottom and back of countertop shall be painted with 3 coats of latex exterior paint for protection.
- ⑤ All screws and fasteners will be stainless steel.

APPROVED BY:
GSWC STANDARDS COMMITTEE

Alison Sweet

EDC MANAGER

6/15/26
DATE



Golden State
Water Company

A Subsidiary of American States Water Company

TITLE:

CHEMICAL BUILDING
WORK TABLE

SCALE:
NONE

DATE:
04/27/26

REV
2026

STANDARD DWG NO.
W-9B

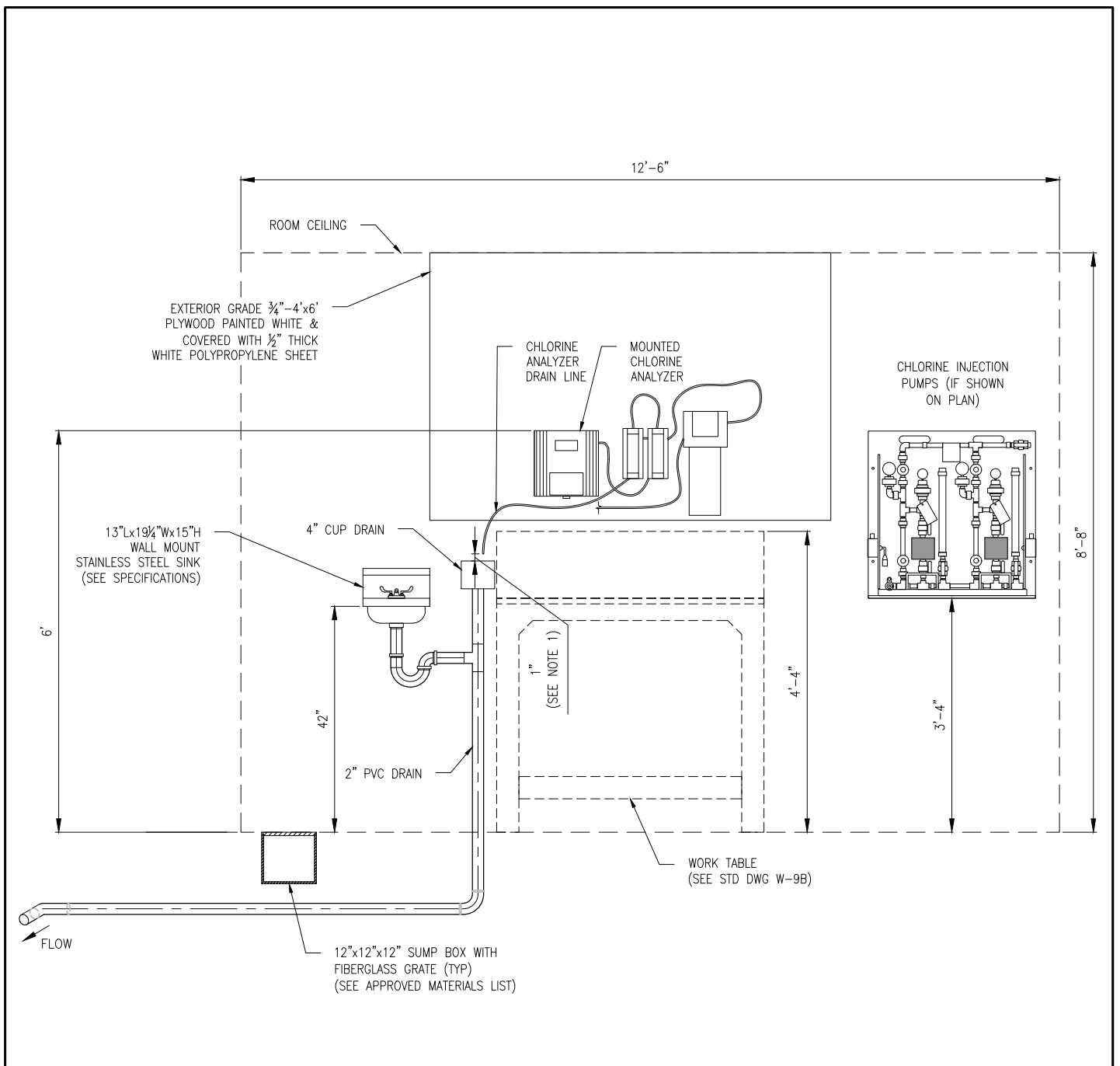

INTERIOR EQUIPMENT WALL (1)
N.T.S. (—)

NOTE:

1. Air gap to be at least twice the diameter of the drain line pipe but no less than 1-inch.

APPROVED BY: GSWC STANDARDS COMMITTEE  EDC MANAGER	 Golden State Water Company <small>A Subsidiary of American States Water Company</small>	TITLE: CHLORINE ANALYZER			
6/15/26 DATE		SCALE: NONE	DATE: 05/05/26	REV 2026	STANDARD DWG NO. W-9C

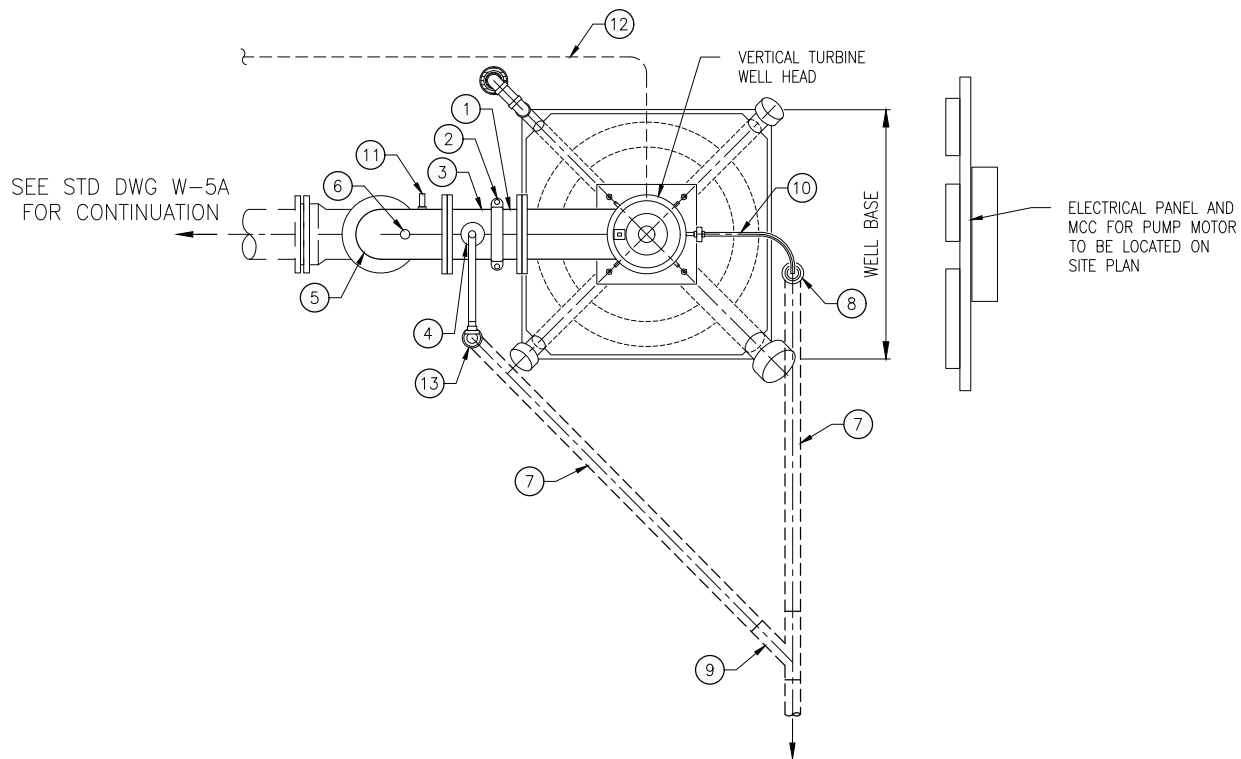

NEW WELL FLOOR PLAN

N.T.S.



CONSTRUCTION NOTES:

- ① — INSTALL STANDARD WEIGHT STEEL SPOOL, FE_xGE.
- ② — INSTALL VICTAULIC COUPLING, STYLE 77.
- ③ — INSTALL STANDARD WEIGHT STEEL SPOOL, FE_xGE, THREADED FOR THE INSTALLATION OF AIR/VACUUM VALVE ASSEMBLY.
- ④ — INSTALL 2" APCO VERTICAL TURBINE AIR/VACUUM VALVE WITH 2" WELDOLET, 2" BALL VALVE AND 2" BUSHINGS PER STD. DWG. W-6
- ⑤ — INSTALL 90° SR STANDARD WEIGHT STEEL ELBOW, FE.
- ⑥ — INSTALL PRESSURE SWITCH AND GAUGE. PER STD. DWG. W-17.
- ⑦ — INSTALL 4" PVC DRAIN
- ⑧ — INSTALL 4" CLEANOUT
- ⑨ — INSTALL 4" DIP WYE
- ⑩ — INSTALL 1" THREAD-O-LET, 3/8" BUSHING AND 3/8" COMPRESSION FITTING AND 3/8" COPPER TUBING TO DRAIN.
- ⑪ — WATER QUALITY SAMPLING PORT ON SIDE OF PIPE PER STD. DWG. W-17.
- ⑫ — 2" COPPER TUBING TO PUMP FOR STARTUP PRE-LUBRICATION WITH TRENCH AND WITH WATER FLUSH MANIFOLD PER THE SPECIFICATIONS
- ⑬ — INSTALL 6" FLOOR DRAIN, SMITH FIGURE 2505

APPROVED BY:
GSWC STANDARDS COMMITTEE

Alison Sweet

EDC MANAGER

6/15/26
DATE



Golden State
Water Company

A Subsidiary of American States Water Company

TITLE:

NEW WELL FLOOR PLAN

SCALE:	DATE:	REV	STANDARD DWG NO.
NONE	05/06/26	2026	W-10A

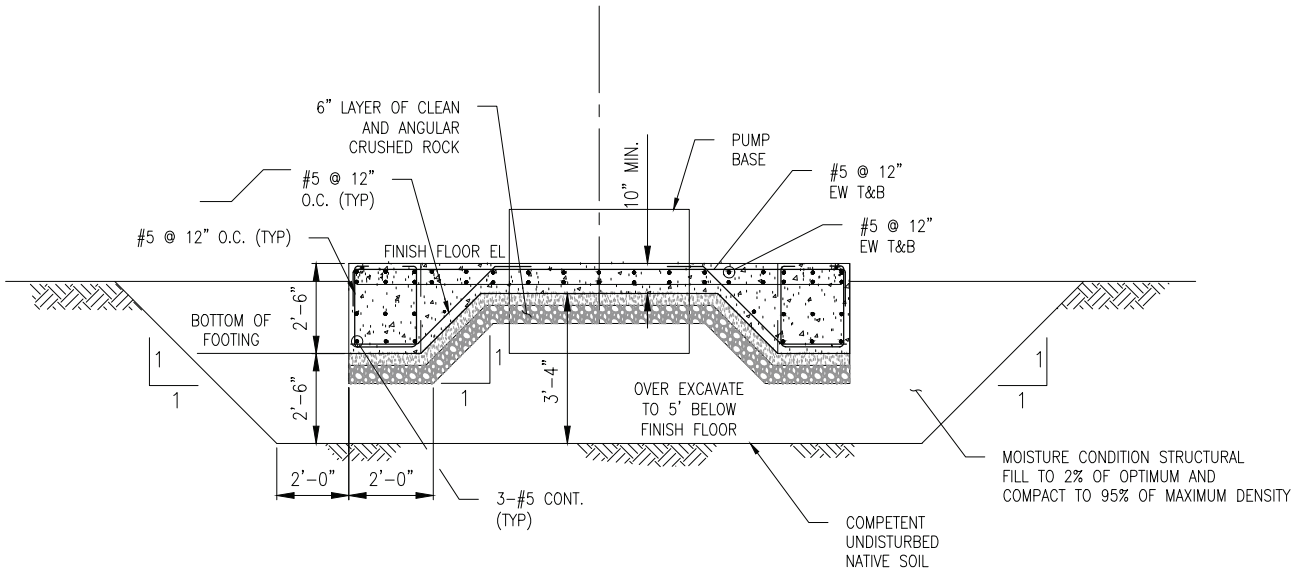

WELL PAD GRADING SECTION

N.T.S.

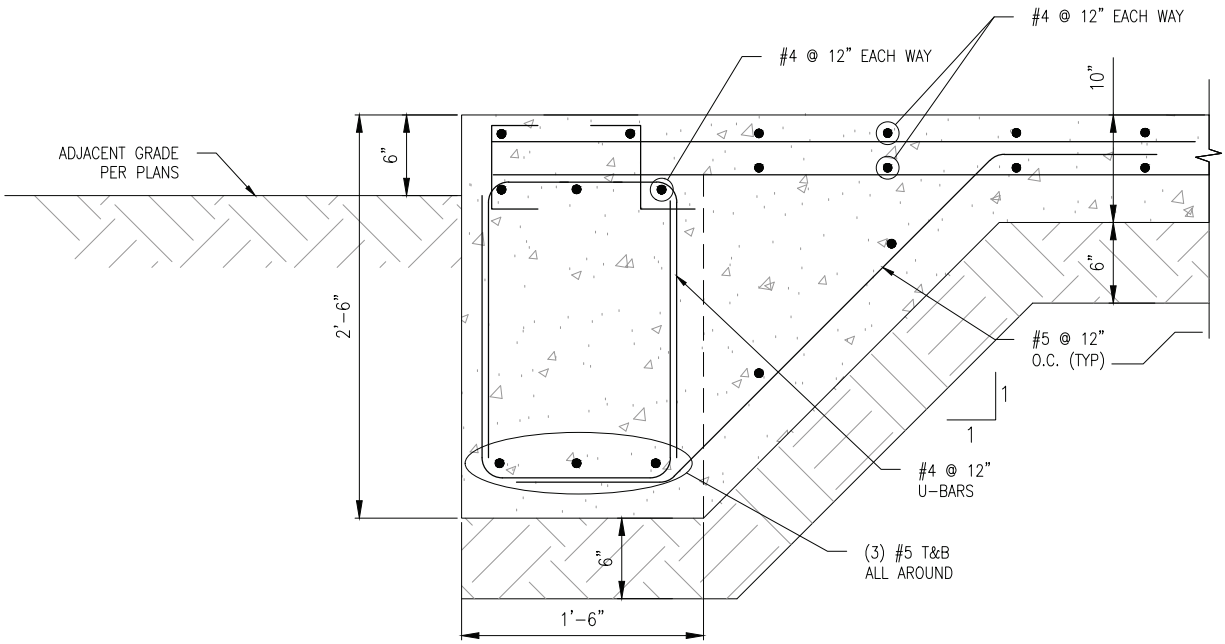

SLAB FOOTING SECTION

N.T.S.



APPROVED BY:
GSWC STANDARDS COMMITTEE

Alison Sweet

EDC MANAGER

6/15/26
DATE



Golden State
Water Company

A Subsidiary of American States Water Company

TITLE:

SLAB FOOTING FOUNDATION DETAIL
WITH SUBBASE AND SOILS PREPARATION

SCALE:	DATE:	REV	STANDARD DWG NO.
NONE	07/31/23	2024	W-10B

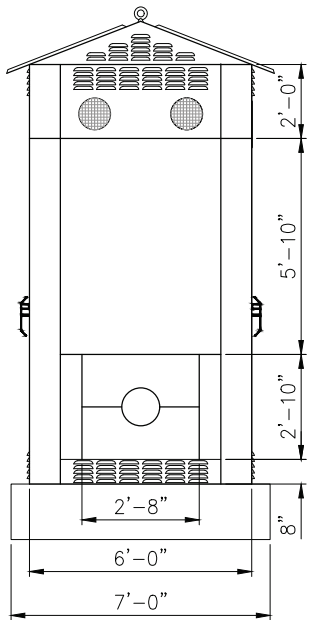

SIDE 4

SIDE 2

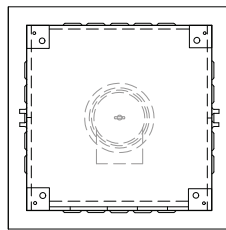

DISCHARGE PIPE
SIDE 1

SIDE 3

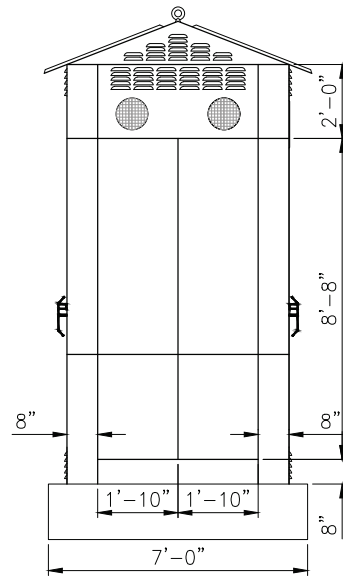

ACOUSTIC PUMP ENCLOSURE SIDE 1

N.T.S.



ACOUSTIC PUMP ENCLOSURE SIDE 2

N.T.S.

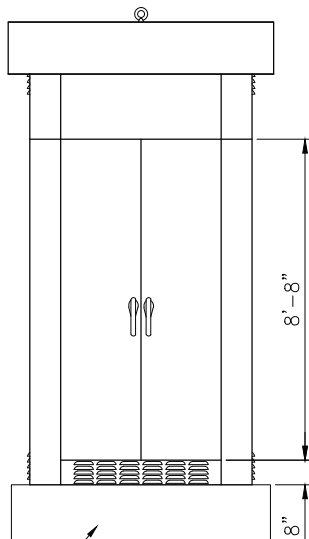

WELL PUMP BASE
(7'SQ x 18" HIGH)

ACOUSTIC PUMP ENCLOSURE SIDE 3

N.T.S.

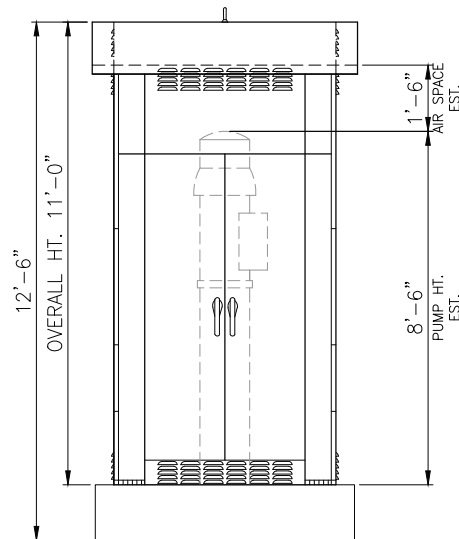

ACOUSTIC PUMP ENCLOSURE SIDE 4

N.T.S.



NOTES:

1. Acoustical enclosure shall be installed by contractor, see approved materials list for manufacturer.
2. The enclosure shall be installed with a boom truck or equivalent.
3. The contractor shall not disassemble pump enclosure for or during installation.
4. Concrete slab, electrical connections and anchor bolts not provided by RPS industries.
5. Powder coat: color shall be selected for each project.
6. Install (4) Grainger fan P/N 4YDY82, (2) Grainger thermostat P/N 2E340

APPROVED BY:
GSWC STANDARDS COMMITTEE

Alison Sweet

EDC MANAGER

6/15/26
DATE



Golden State
Water Company

A Subsidiary of American States Water Company

TITLE:

ACOUSTIC WELL PUMP ENCLOSURE

SCALE:	DATE:	REV	STANDARD DWG NO.
NONE	04/20/26	2026	W-11

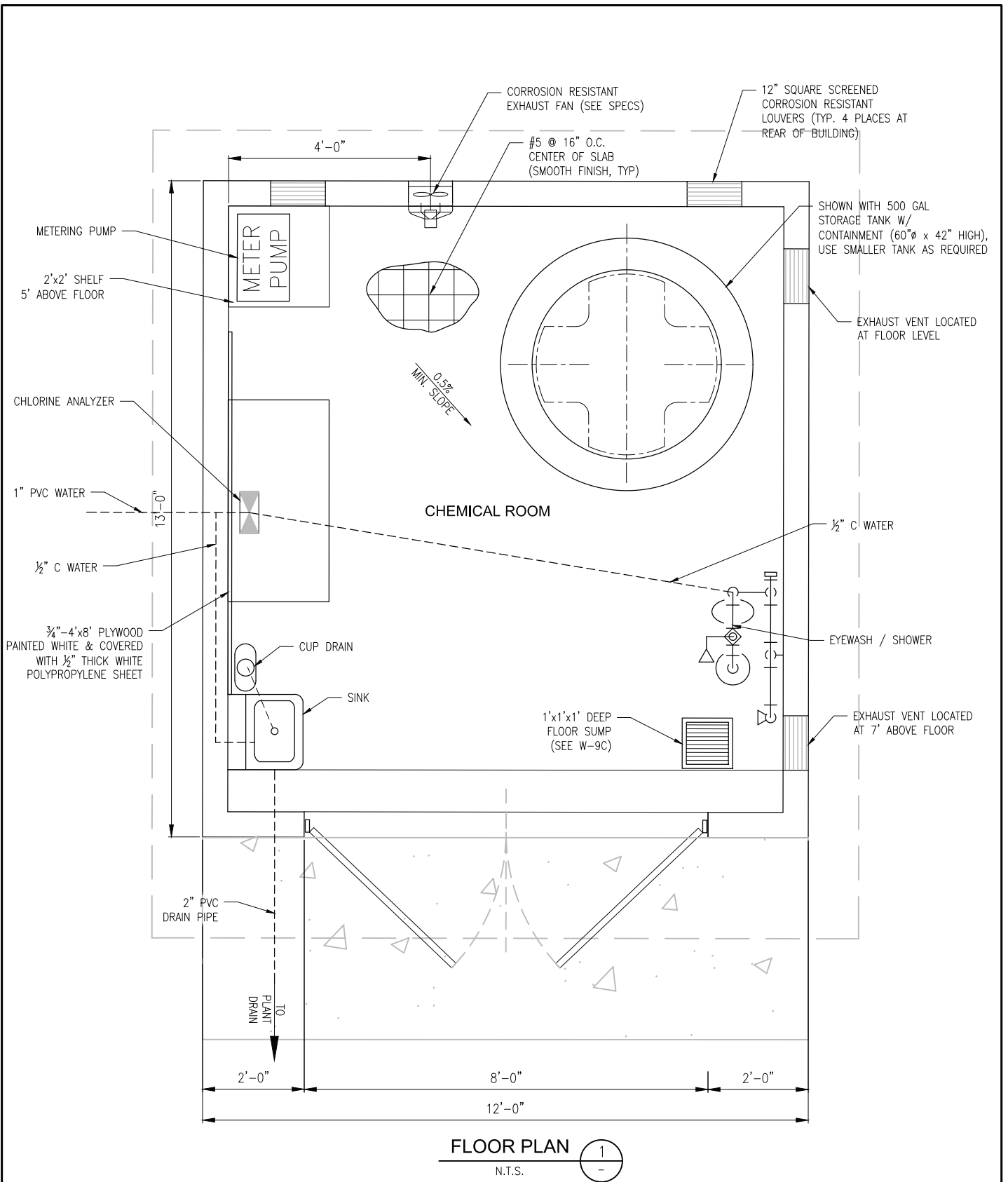

NOTE:
See pump station building structural drawings for building framing and roof details.

APPROVED BY:
GSWC STANDARDS COMMITTEE

Alison Sweet
EDC MANAGER

6/15/26
DATE



TITLE:
**FLOOR PLAN OF
DISINFECTION BUILDING
(1-BAY BUILDING)**

SCALE: NONE	DATE: 07/31/23	REV 2024	STANDARD DWG NO. W-12A
----------------	-------------------	-------------	---------------------------

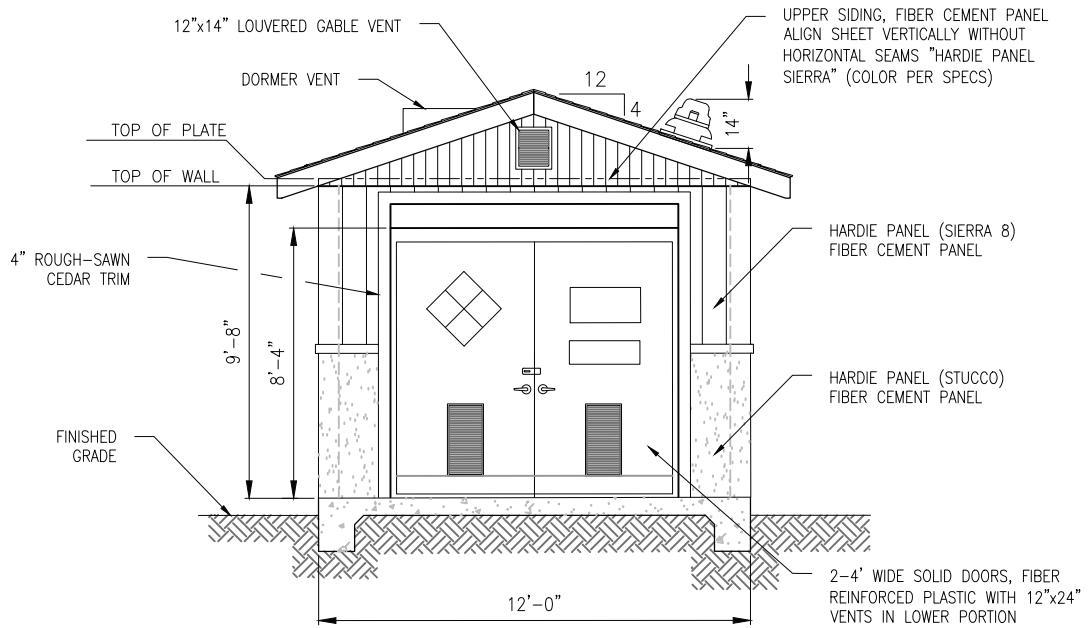

FRONT ELEVATION

N.T.S.

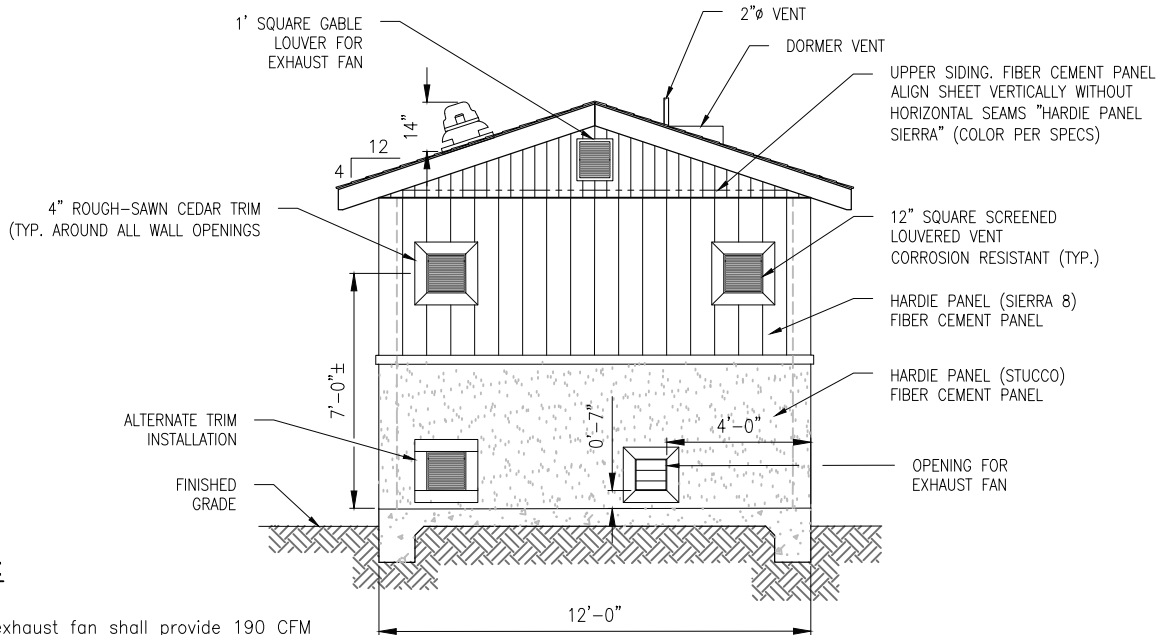

REAR ELEVATION

N.T.S.



NOTES:

1. Roof exhaust fan shall provide 190 CFM air flow. use Cook ACE-D(70 C15 DH) or approved equal. Fan to be installed parallel to roof.
2. All interior corners and seams in the walls and ceiling shall be sealed with a rubber silicone joint sealant resistant to chlorine vapors prior to painting.

APPROVED BY:
GSWC STANDARDS COMMITTEE

Alison Sweet

EDC MANAGER

6/15/26
DATE



Golden State
Water Company

A Subsidiary of American States Water Company

TITLE:

ARCHITECTURAL VIEWS OF
DISINFECTION BUILDING
(1-BAY BUILDING)

SCALE:	DATE:	REV	STANDARD DWG NO.
NONE	07/31/23	2024	W-12B

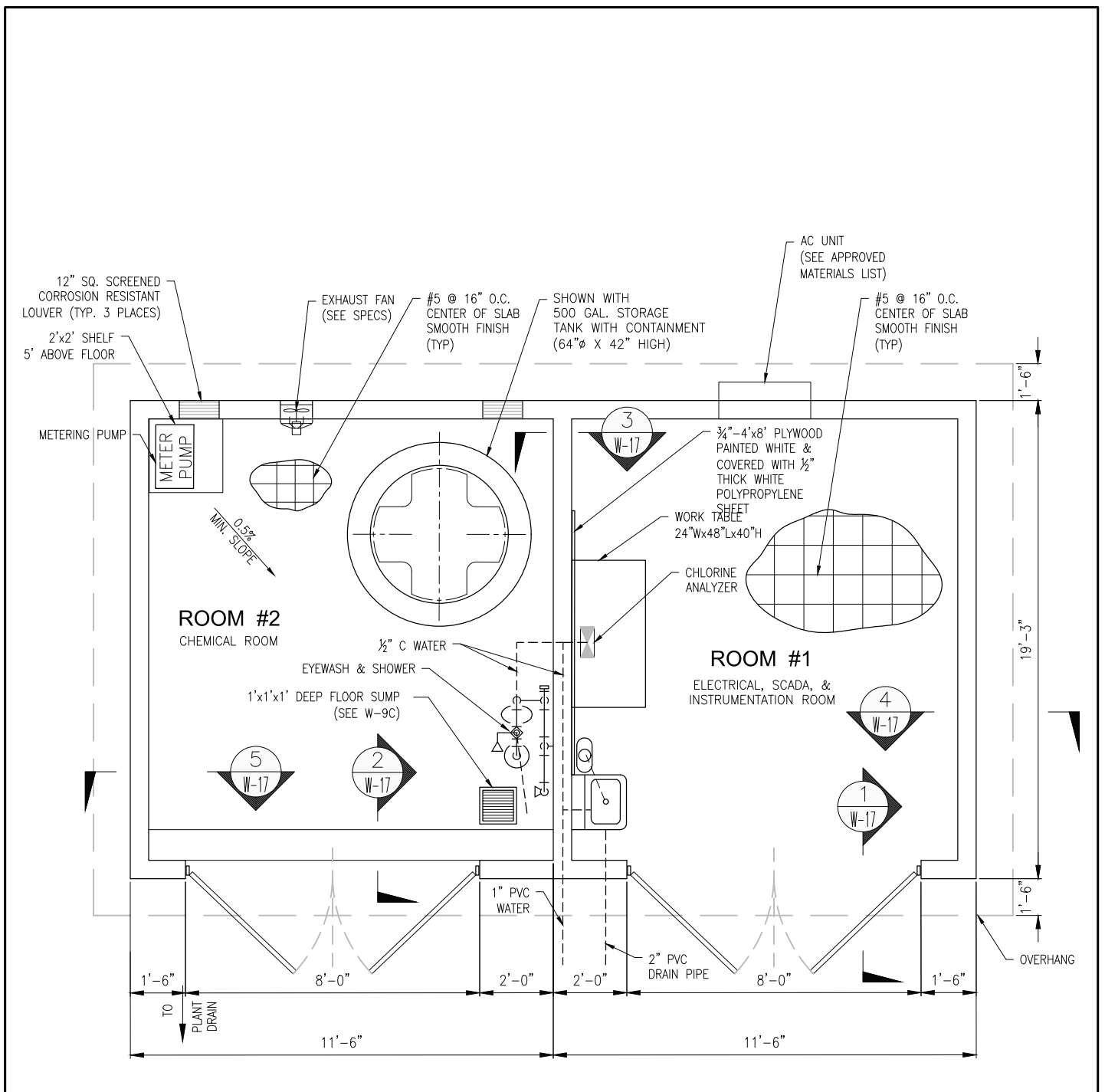

FLOOR PLAN (1) N.T.S.

NOTE:
See pump station building structural drawings for building framing and roof details.

APPROVED BY:
GSWC STANDARDS COMMITTEE

Alison Sweet
EDC MANAGER

6/15/26
DATE



TITLE: FLOOR PLAN OF DISINFECTION BUILDING (2-BAY BUILDING)			
SCALE: NONE	DATE: 03/31/26	REV 2026	STANDARD DWG NO. W-13A

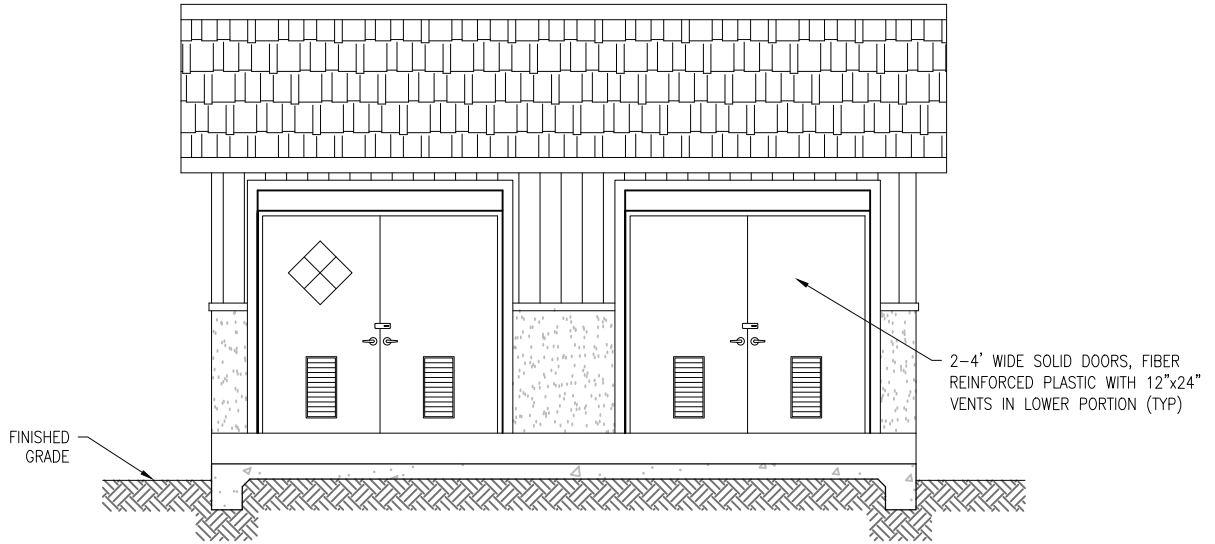

FRONT ELEVATION (A)
N.T.S.

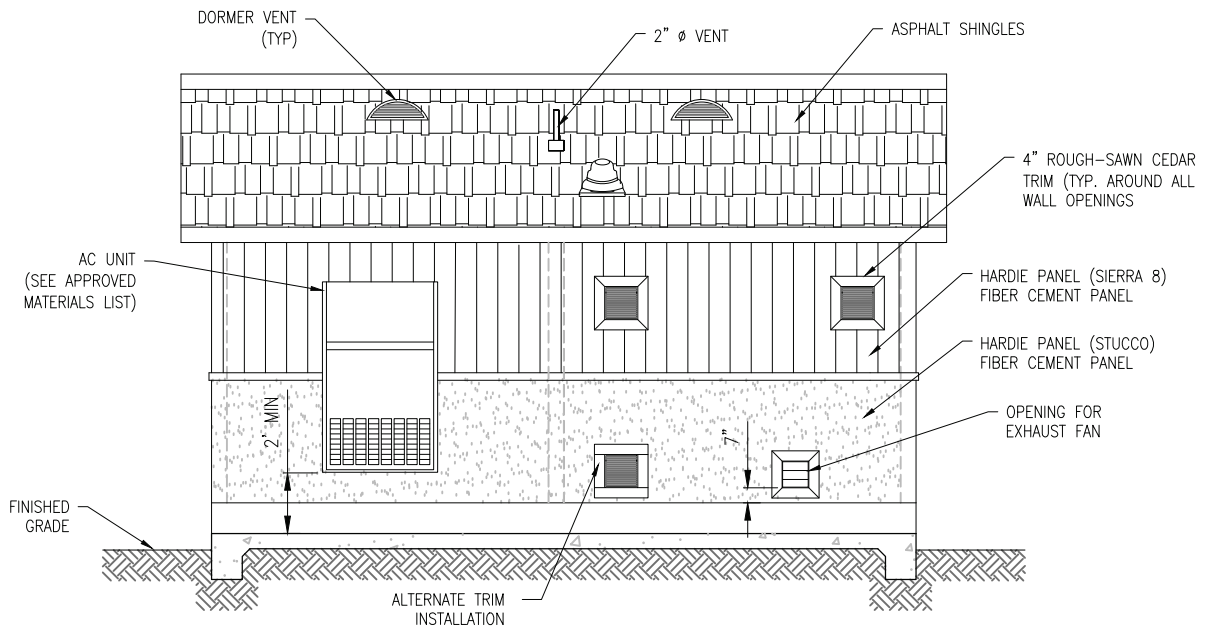

REAR ELEVATION (B)
N.T.S.

NOTES:

1. Roof exhaust fan shall provide 190 CFM air flow. use cook ACE-D(70 C15 DH) or approved equal. fan to be installed parallel to roof.
2. All interior corners and seams in the walls and ceiling shall be sealed with a rubber silicone joint sealant resistant to chlorine vapors prior to painting.

APPROVED BY:
GSWC STANDARDS COMMITTEE

Alison Sweet

EDC MANAGER

6/15/26
DATE



Golden State
Water Company

A Subsidiary of American States Water Company

TITLE:

ARCHITECTURAL VIEWS OF
DISINFECTION BUILDING
(2-BAY BUILDING)

SCALE:
NONE

DATE:
03/31/26

REV
2026

STANDARD DWG NO.
W-13B

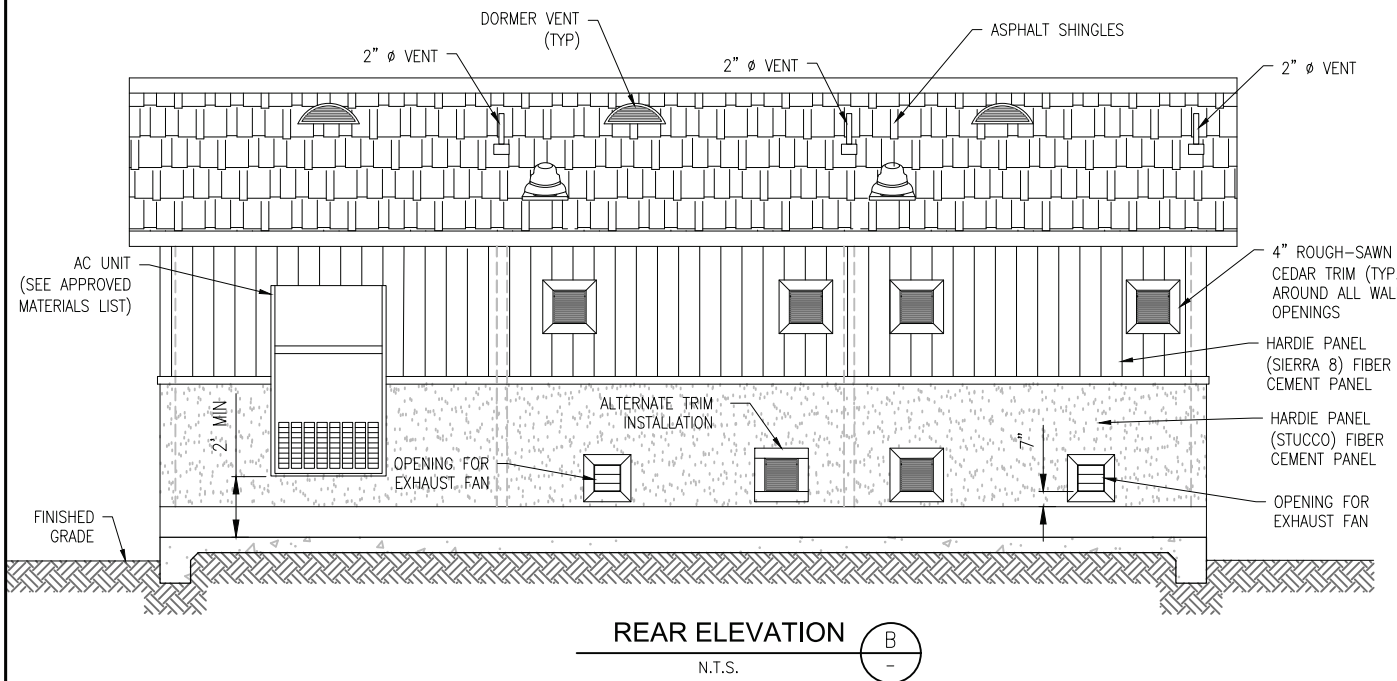
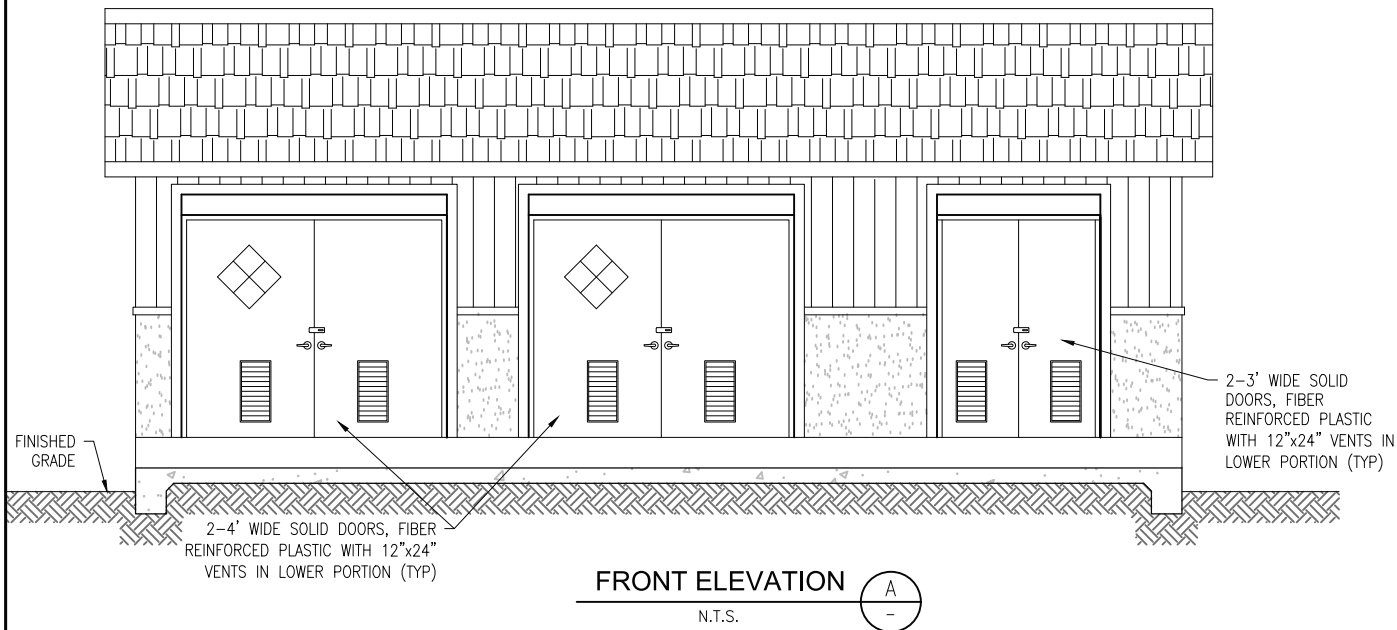

NOTES:

1. Roof exhaust fan shall provide 190 CFM air flow. use cook ACE-D(70 C15 DH) or approved equal. fan to be installed parallel to roof.
2. All interior corners and seams in the walls and ceiling shall be sealed with a rubber silicone joint sealant resistant to chlorine vapors prior to painting.

APPROVED BY:
GSWC STANDARDS COMMITTEE

Alison Sweet

EDC MANAGER

6/15/26
DATE



Golden State
Water Company

A Subsidiary of American States Water Company

TITLE:

ARCHITECTURAL VIEWS OF
DISINFECTION BUILDING
(3-BAY BUILDING)

SCALE:	DATE:	REV	STANDARD DWG NO.
NONE	04/01/26	2026	W-14B

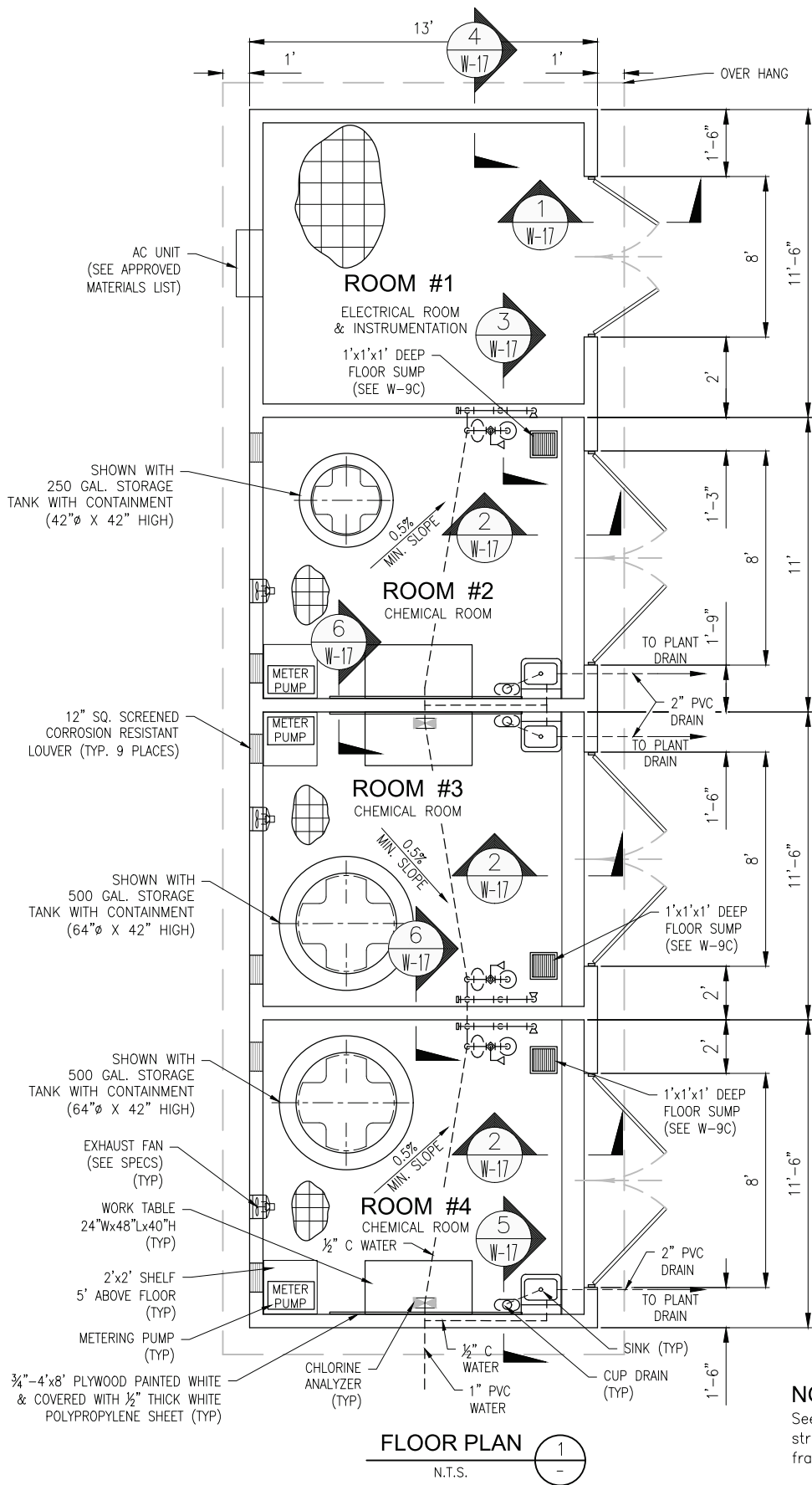

APPROVED BY:
GSWC STANDARDS COMMITTEE

Alison Sweet

6/15/26

EDC MANAGER

DATE



Golden State
Water Company

A Subsidiary of American States Water Company

TITLE:

FLOOR PLAN OF
DISINFECTION BUILDING
(4 BAY BUILDING)

SCALE:

NONE

DATE:

03/31/26

REV

2026

STANDARD DWG NO.

W-15A

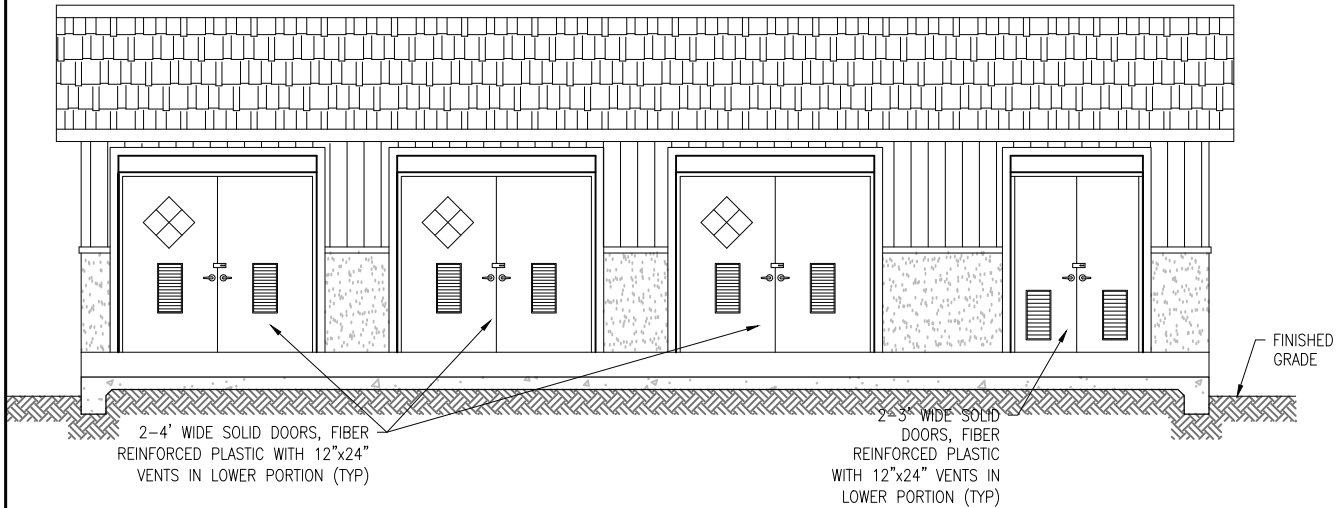

FRONT ELEVATION (A)
N.T.S.

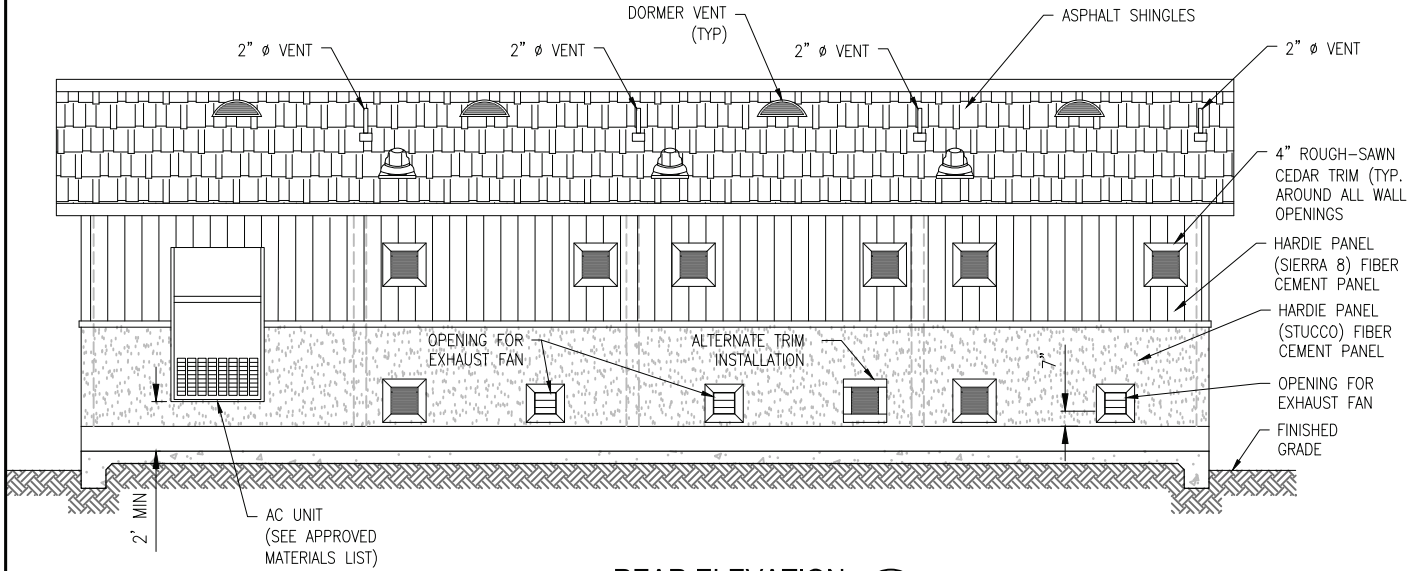

REAR ELEVATION (B)
N.T.S.

NOTES:

1. Roof exhaust fan shall provide 190 CFM air flow. use cook ACE-D(70 C15 DH) or approved equal. fan to be installed parallel to roof.
2. All interior corners and seams in the walls and ceiling shall be sealed with a rubber silicone joint sealant resistant to chlorine vapors prior to painting.

APPROVED BY: GSWC STANDARDS COMMITTEE  EDC MANAGER 6/15/26 DATE	 <p align="center">Golden State Water Company</p> <p align="center">A Subsidiary of American States Water Company</p>	TITLE: ARCHITECTURAL VIEWS OF DISINFECTION BUILDING (4-BAY BUILDING) SCALE: NONE DATE: 04/04/26 REV: 2026 STANDARD DWG NO. W-15B
---	---	---

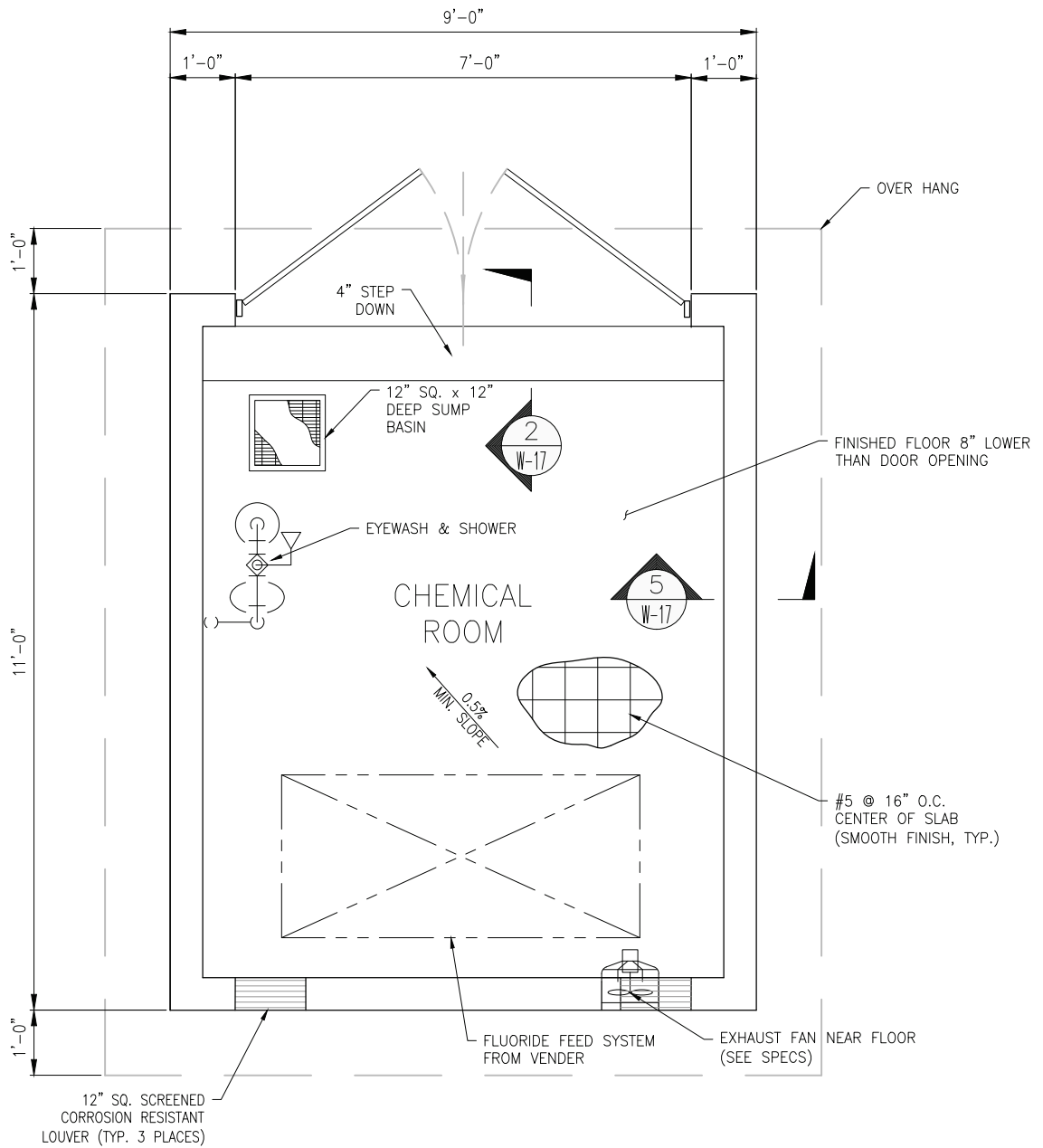

FLOOR PLAN 1
N.T.S.

NOTE:

See pump station building structural drawings for building framing and roof details.

APPROVED BY:
GSWC STANDARDS COMMITTEE

Alison Sweet

EDC MANAGER

6/15/26
DATE



Golden State
Water Company

A Subsidiary of American States Water Company

TITLE:

FLOOR PLAN OF
FLUORIDE INJECTION BUILDING

SCALE:	DATE:	REV	STANDARD DWG NO.
NONE	03/31/26	2026	W-16A

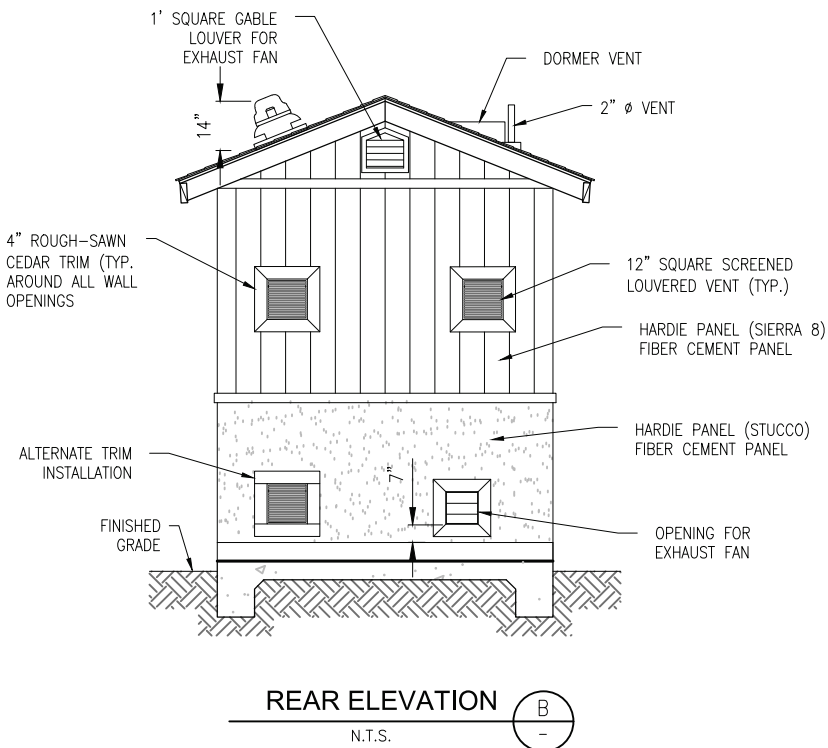
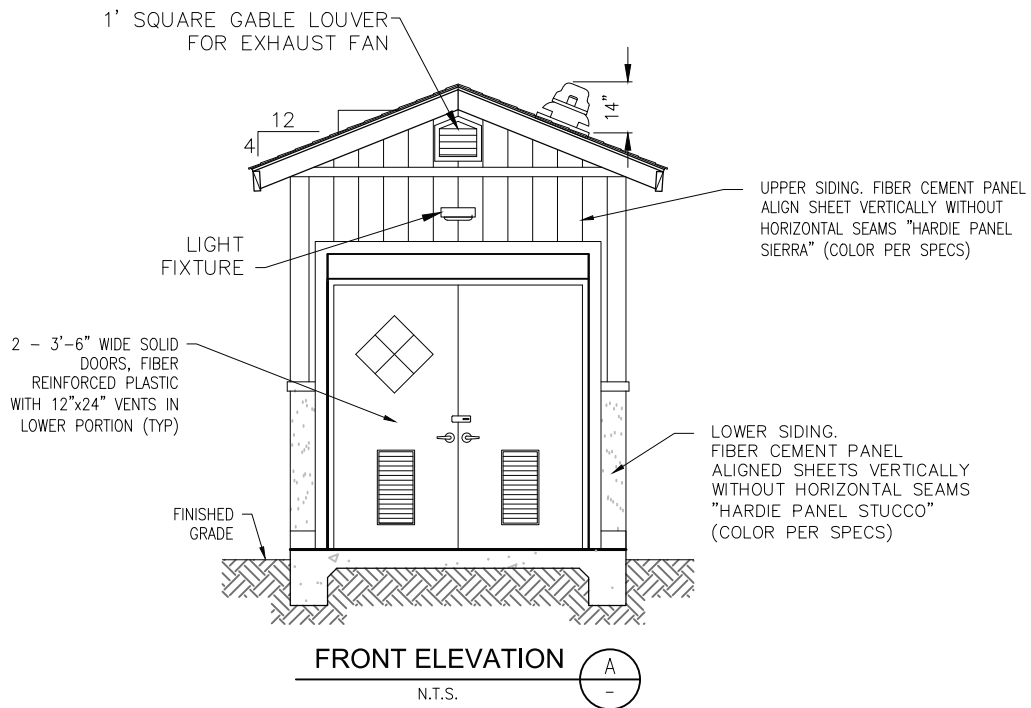

NOTES:

1. Roof exhaust fan shall provide 190 CFM air flow. use cook ACE-D(70 C15 DH) or approved equal. fan to be installed parallel to roof.
2. All interior corners and seams in the walls and ceiling shall be sealed with a rubber silicone joint sealant resistant to chlorine vapors prior to painting.

APPROVED BY:
GSWC STANDARDS COMMITTEE

Alison Sweet

EDC MANAGER

6/15/26
DATE



Golden State
Water Company

A Subsidiary of American States Water Company

TITLE:

ARCHITECTURAL VIEWS OF
FLUORIDE INJECTION BUILDING

SCALE:
NONE

DATE:
07/31/23

REV
2024

STANDARD DWG NO.
W-16B

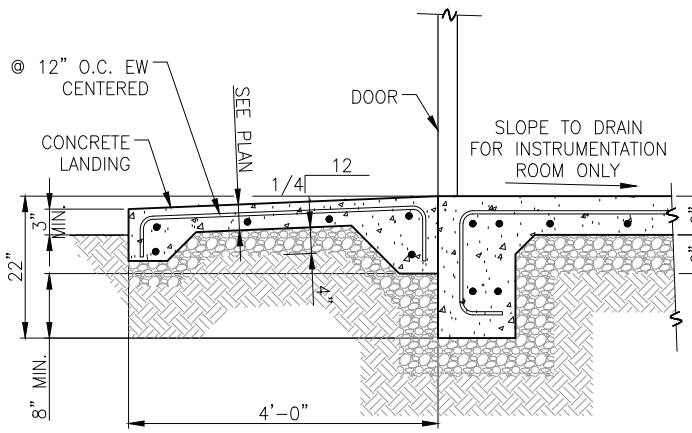

ELECTRICAL ROOM ENTRANCE

1
-

N.T.S.

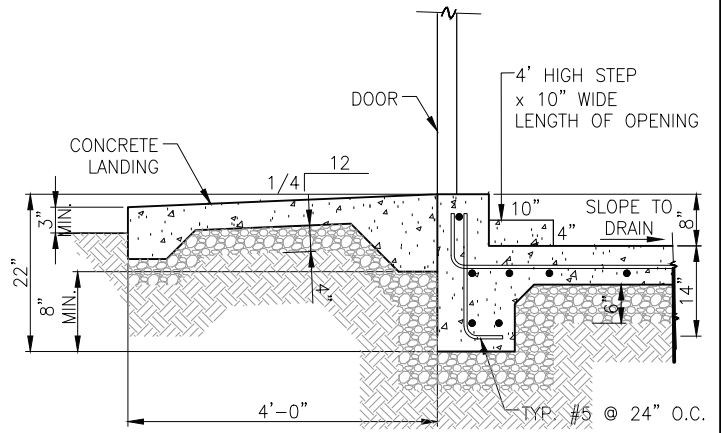

CHEMICAL ROOM ENTRANCE

2
-

N.T.S.

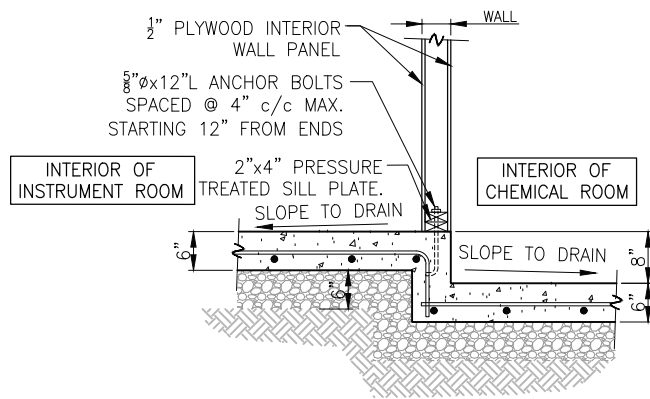

SLAB DETAIL BETWEEN ROOMS

3
-

N.T.S.

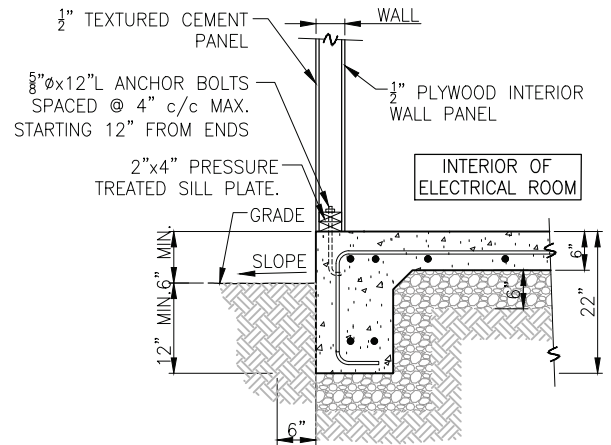

ELECTRICAL ROOM SLAB / WALL DETAIL

4
-

N.T.S.

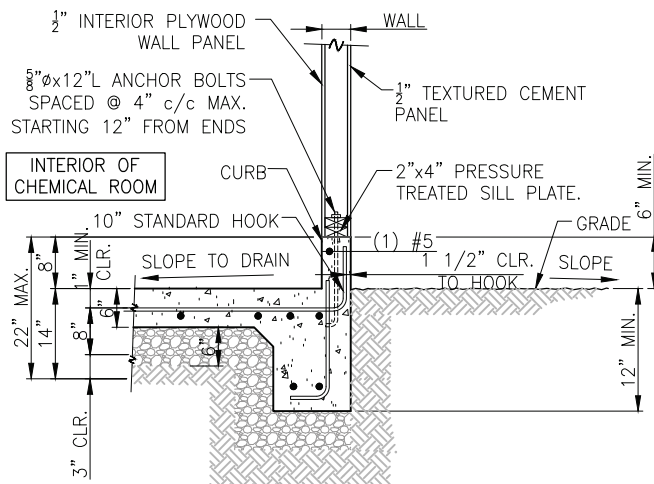

CHEMICAL ROOM SLAB / WALL DETAIL

5
-

N.T.S.

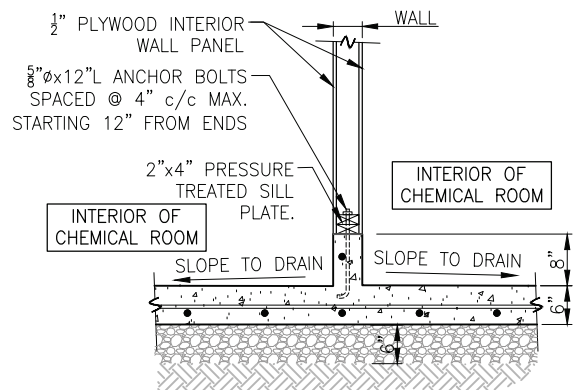

SLAB DETAIL BETWEEN CHEMICAL ROOMS

6
-

N.T.S.

APPROVED BY:
GSWC STANDARDS COMMITTEE

Alison Sweet

EDC MANAGER

6/15/26
DATE



Golden State
Water Company

A Subsidiary of American States Water Company

TITLE:

SLAB AND FOUNDATION
STRUCTURAL DETAILS

SCALE:	DATE:	REV	STANDARD DWG NO.
NONE	07/31/23	2024	W-17

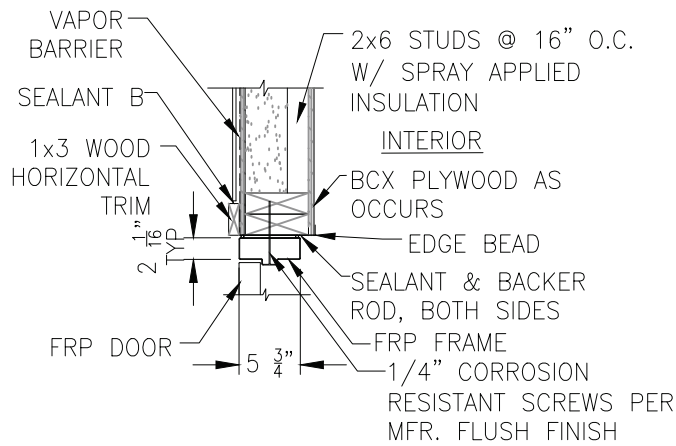

DOOR JAMB (1)
N.T.S.

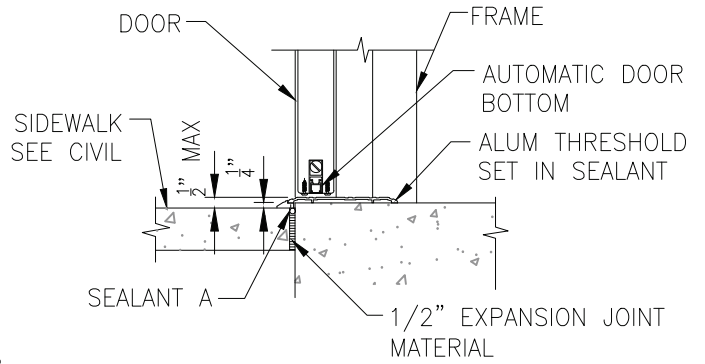

EXTERIOR DOOR SILL (2)
N.T.S.

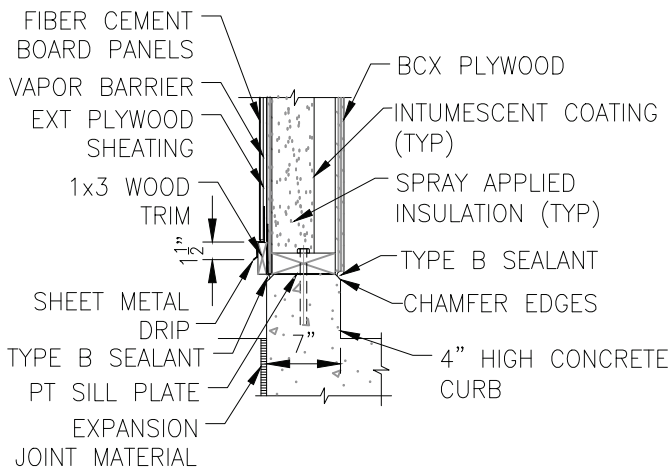

CURB DETAIL (3)
N.T.S.

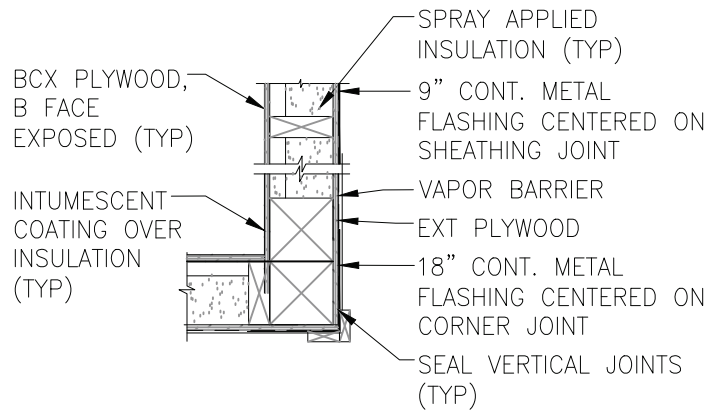

CORNER DETAIL (4)
N.T.S.

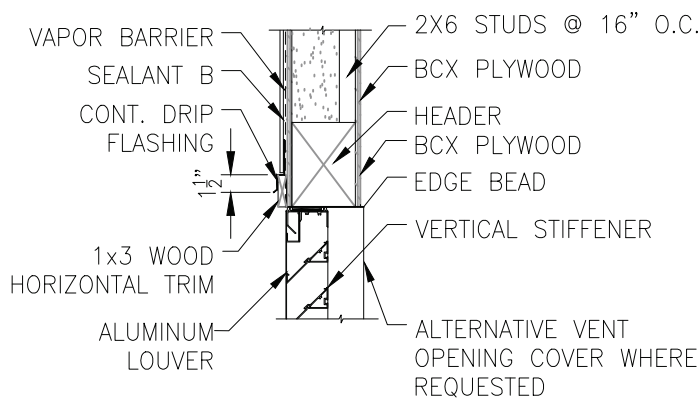

VENT INSTALLATION (5)
N.T.S.

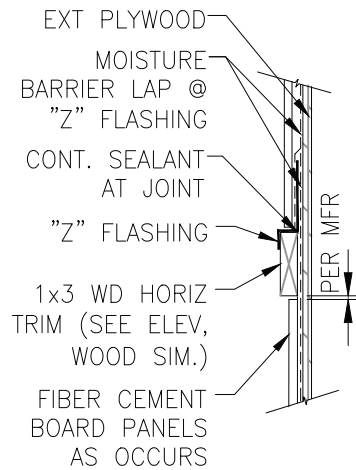

TRIM SECTION DETAIL (6)
N.T.S.

APPROVED BY:
GSWC STANDARDS COMMITTEE

Alison Sweet

EDC MANAGER

6/15/26
DATE



Golden State
Water Company

A Subsidiary of American States Water Company

TITLE:

CHEMICAL BUILDING DOOR AND LOUVER DETAILS

SCALE:	DATE:	REV	STANDARD DWG NO.
NONE	07/31/23	2024	W-18



BLUE LETTERS

WHITE METAL SIGN

SITE ADDRESS SIGN

LOCATE ON ENTRANCE GATE & BUILDING

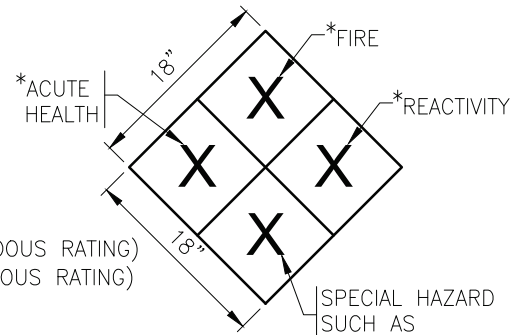

*(0 IS LEAST HAZARDOUS RATING)
(4 IS MOST HAZARDOUS RATING)

NOTE:

SEE N.F.P.A. 704 FOR COLOR AND SIZE OF NUMERALS AND LETTERS.

SPECIAL HAZARD SUCH AS
OX = OXIDIZER
COR = CORROSIVE

N.F.P.A. HAZARDOUS MATERIALS IDENTIFICATION SIGN

LOCATE ON SITE ENTRANCE GATES, BUILDING AND EACH ROOM ENTRANCE. GSWC SHALL CONFIRM RATINGS ON ALL SIGNS FOR ACTUAL MATERIAL USED

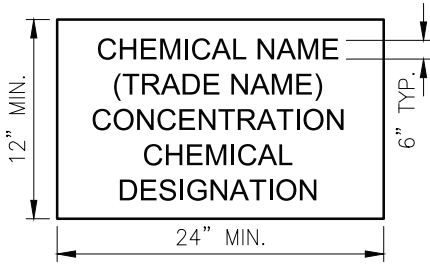

CHEMICAL NAME SIGN

LOCATE ON ROOM ENTRANCE

WHITE METAL SIGN

RED LETTERS

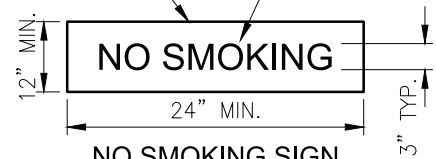

NO SMOKING SIGN

LOCATE ON ENTRANCE GATE & BUILDING

TYPICAL SIGN DETAILS (1)
N.T.S.

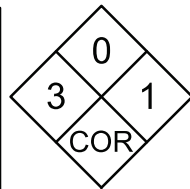
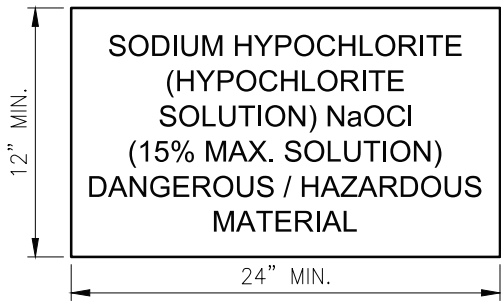

HAZARD SIGN

SODIUM HYPOCHLORITE CHEMICAL SIGN (2)
N.T.S.

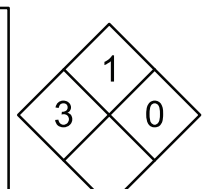
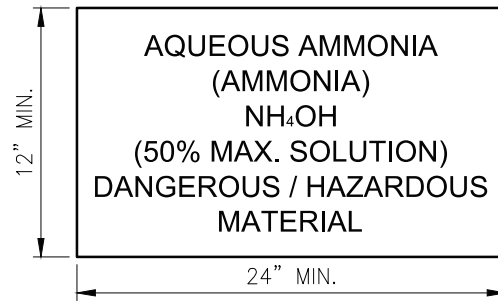

HAZARD SIGN

AQUEOUS AMMONIA CHEMICAL SIGN (3)
N.T.S.

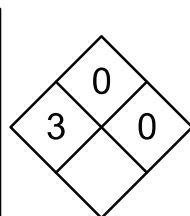
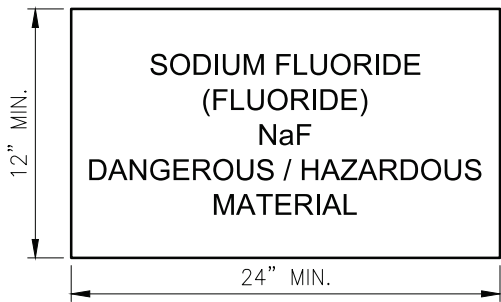

HAZARD SIGN

SODIUM FLUORIDE CHEMICAL SIGN (4)
N.T.S.

NOTES:

- 1) N.F.P.A. signs shown are typical examples
- 2) Exact N.F.P.A. signs shall be as directed by GSWC and/or chemical supplier.
- 3) N.F.P.A. ratings are specific to the hazardous material and concentrations. Ratings should be drawn from the supplier or manufacturer SDS.

APPROVED BY:
GSWC STANDARDS COMMITTEE

Alison Sweet

EDC MANAGER

6/15/26
DATE



Golden State
Water Company

A Subsidiary of American States Water Company

TITLE:

CHEMICAL BUILDING SIGNAGE

SCALE:
NONE

DATE:
07/31/23

REV
2024

STANDARD DWG NO.
W-19A

CHEMICAL STORAGE NOTES

1. Building Requirements
 - a. The Disinfection Building shall be constructed of either wood frame construction, pre-cast concrete or cement masonry block (CMU) as shown on the plans for each specific project.
 - i. All exposed electrical conduits shall be constructed of non-corrosive materials except where metal conduits used in the concrete slab project above the floor. Such projections of metal conduits shall be wrapped with PVC tape.
 - ii. The doors, frames and ventilation equipment shall be constructed of non-corrosive materials such as Fiberglass Reinforced Plastic (FRP), aluminum or stainless steel to minimize corrosion from chemical vapors that will be present in the chemical rooms.
 - b. GSWC does not have an NPDES permit at any site that would allow the discharge of a hazardous material or chemical to a storm drain or sanitary sewer. Floor drains should only discharge to a sump onsite for collection, pumping, and disposal of hazmat spills by a vender.
 - d. All rooms of the Disinfection Building shall be securely locked when employees are not present.
 - e. A Safety Data Sheet (SDS) shall be maintained on the premises and be readily available for reference.
2. Storage Tank Requirements
 - a. Storage tanks with double walls for secondary containment shall be furnished by either GSWC or an outside vendor. See the Bid Sheets for specific requirements on each project. Chemical treatment will be provided to the ground water pumped from the local wells by injection of sodium hypochlorite and/or other water treatment chemicals.
 - i. The secondary containment shall be capable of holding 100% of the storage tank volume without spilling over the top.
 - b. Storage tanks shall be either a 275 gallon or 500 gallon double-walled tank for storing sodium hypochlorite. (See the Plans for specific tank size.) Other tank sizes may be called for on the construction plans.
 - c. Chemical tanks shall be clearly marked and labeled in accordance with nationally recognized standards.
 - d. There may be other chemicals stored in the building which are used for further water treatment. These may include but not be limited to ammonia and sodium fluoride.
 - i. Each chemical shall be in its own room with its own double-walled chemical storage tank and its own chemical injection pump system.
 - e. All chemical tanks and related equipment shall be anchored to meet anticipated seismic loads per the latest requirements of the California Building Standards Code (CBSC).
 - f. Tanks shall be equipped with level measurement equipment connected to the local SCADA system. The SCADA system shall be modified to signal the District's Operations Staff on tank level and leak detection.
3. Chemical Piping Requirements
 - a. All chemical piping shall be accordance with 8001.4.3 of the California Fire Code (CFC). Tubing carrying the chemicals shall be fully contained in rigid Schedule 80 PVC piping.
 - b. All chemical piping shall be clearly identified in English to indicate material being conveyed and showing the direction of flow.
 - c. Shutoff valves shall be installed on the chemical injection systems at the following locations:
 - i. At the pump suction point on each tank.
 - ii. At each injection point within the plant.
 - iii. On both sides of each pump.
 - d. All shutoff valves shall be identified by signs.
 - e. Check valves shall be installed at all locations where backflows could create a hazardous condition or unauthorized discharge of hazardous materials.
 - f. Installation Instructions
 - i. Materials: Use ½" OD black polypropylene fittings, ½' black polypropylene tubing, 2" schedule 80 PVC pipe, 2" male adapters and 2" Nalgene clear vinyl tubing with stainless steel hose clamps.
 - ii. Installation:
 1. The Schedule 80 PVC pipe shall be installed below ground with long sweeps at each turn.
 2. A socket female thread coupling and male hose adapter shall be placed at each end of the pipe.
 3. The clear vinyl tubing shall be installed over the male hose adapters with hose clamps.
 4. The black polyethylene line shall be pulled through the PVC pipe and clear vinyl tubing.
 5. The black polyethylene line shall be connected at the pump and the point of injection with the black polyethylene fittings and the clear vinyl tubing pulled over the fittings and clamped.
4. Sign Requirements
 - a. Signs shall be installed at the following locations:
 - i. Hazardous Material Signs complying with National Fire Protection Association (NFPA) 704 shall be installed:
 1. At entrances to the site. Where there are multiple hazardous materials (HMs) at a given site, the NFPA sign(s) at entrance gates should contain the highest ratings from the site HMs, within each NFPA quadrant. This way, emergency responders will know before entering a site, what the severest health, fire, and special hazards are.
 2. At entrances to buildings.
 3. On each tank.
 - ii. No Smoking Signs shall be posted at all buildings.
 - b. A Site Location Sign shall be attached on each entrance gate using 3-inch high blue letters on a white background. The sign material shall be 0.08-inch thick sheet aluminum. Mount the sign on the outside of the gates using the wording shown on the plans.
 - i. At a minimum provide the site address and a 24-hour phone number.

APPROVED BY:
GSWC STANDARDS COMMITTEE

Alison Sweet

EDC MANAGER

6/15/26
DATE



Golden State
Water Company

A Subsidiary of American States Water Company

TITLE:

CHEMICAL BUILDING
SIGNAGE / USAGE NOTES

SCALE:	DATE:	REV	STANDARD DWG NO.
NONE	07/31/23	2024	W-19B

HAZARDOUS MATERIAL NOTES:

1. Storage tanks shall have secondary containment capable of holding storage tank contents.
2. Tanks shall be clearly marked and labeled in accordance with nationally recognized standards.
3. A safety data sheet (S.D.S.) shall be maintained on the premises and be readily available.
4. Piping for chemicals, all materials being used for primary lines and secondary containment lines shall be compatible with the chemical solutions and shall be

as follows:

USE:

1/2" O.D. black polypropylene fittings, 1/2" black polypropylene tubing, 2" schedule 80 PVC pipe and 2" male adapters and 2" nalgene clear vinyl tubing with stainless steel hose clamps. The PVC pipe shall be installed below ground with long sweeps at each turn. A socket female thread coupling and male hose adapter shall be placed at each end of the pipe. The clear vinyl shall be installed over the male hose adapters with hose clamps. The black polyethylene line shall be pulled through the PVC pipe and clear vinyl tubing. The black polyethylene line shall be connected at the pump and the point of injection with the black polyethylene fittings and the clear vinyl pulled over the fittings and clamped. This procedure shall be the same for the suction line.

5. Shut off valves shall be located on all chemical piping at pumps and at injection points.

APPROVED BY:
GSWC STANDARDS COMMITTEE

Alison Sweet

EDC MANAGER

6/15/26
DATE



Golden State
Water Company

A Subsidiary of American States Water Company

TITLE:

CHEMICAL BUILDING HAZARDOUS
MATERIAL NOTES

SCALE:
NONE

DATE:
07/31/23

REV
2024

STANDARD DWG NO.
W-19C

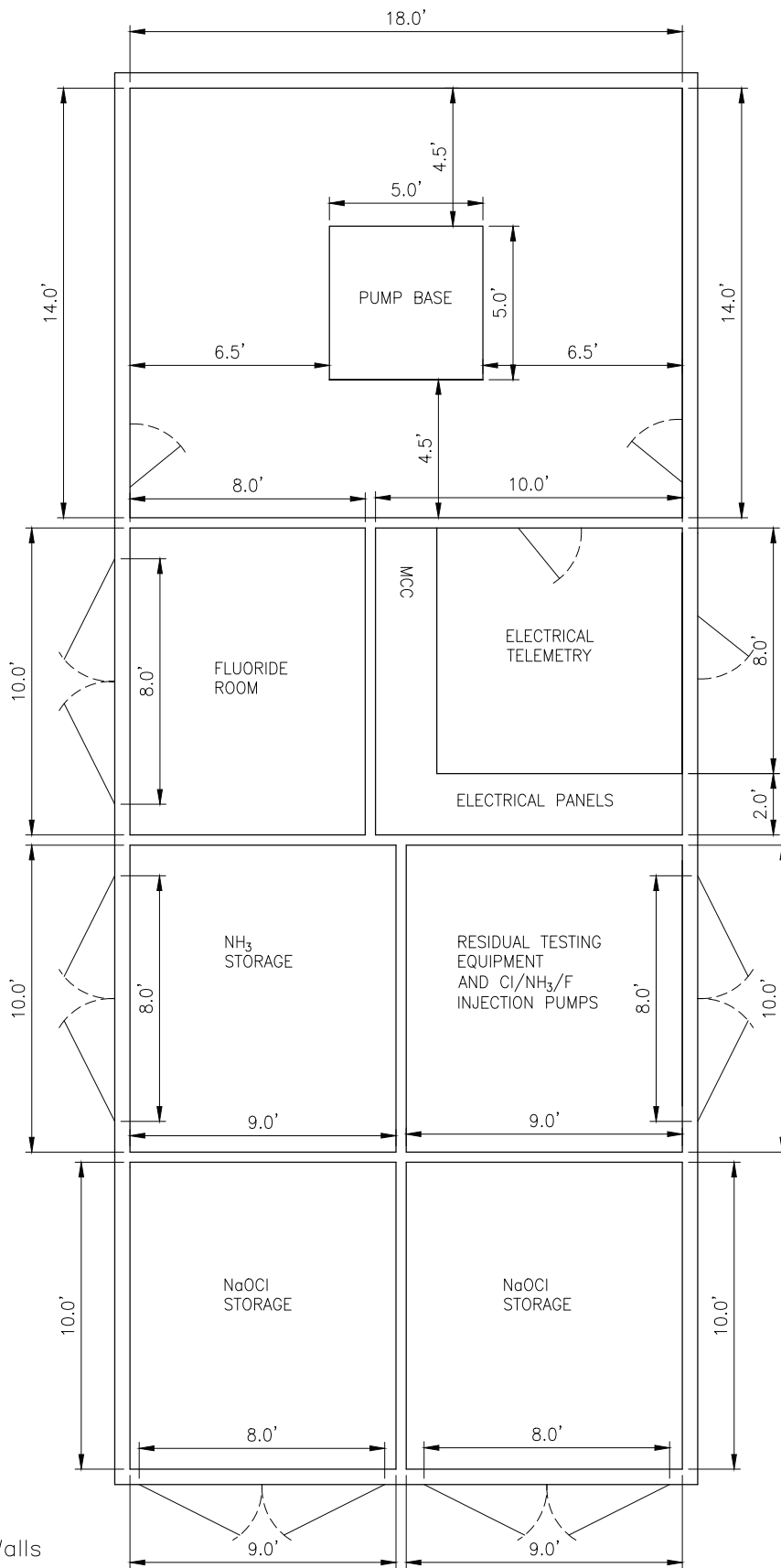

NOTE:

2"X6" Exterior Walls
 2"X4" Interior Walls

APPROVED BY:
 GSWC STANDARDS COMMITTEE

Alison Sweet
 EDC MANAGER

6/15/26
 DATE



Golden State
 Water Company

A Subsidiary of American States Water Company

TITLE:

FLOOR PLAN OF WELL BUILDING
 WITH REMOVABLE ROOF
 AND WALLS

SCALE:	DATE:	REV	STANDARD DWG NO.
NONE	07/31/23	2024	W-20A

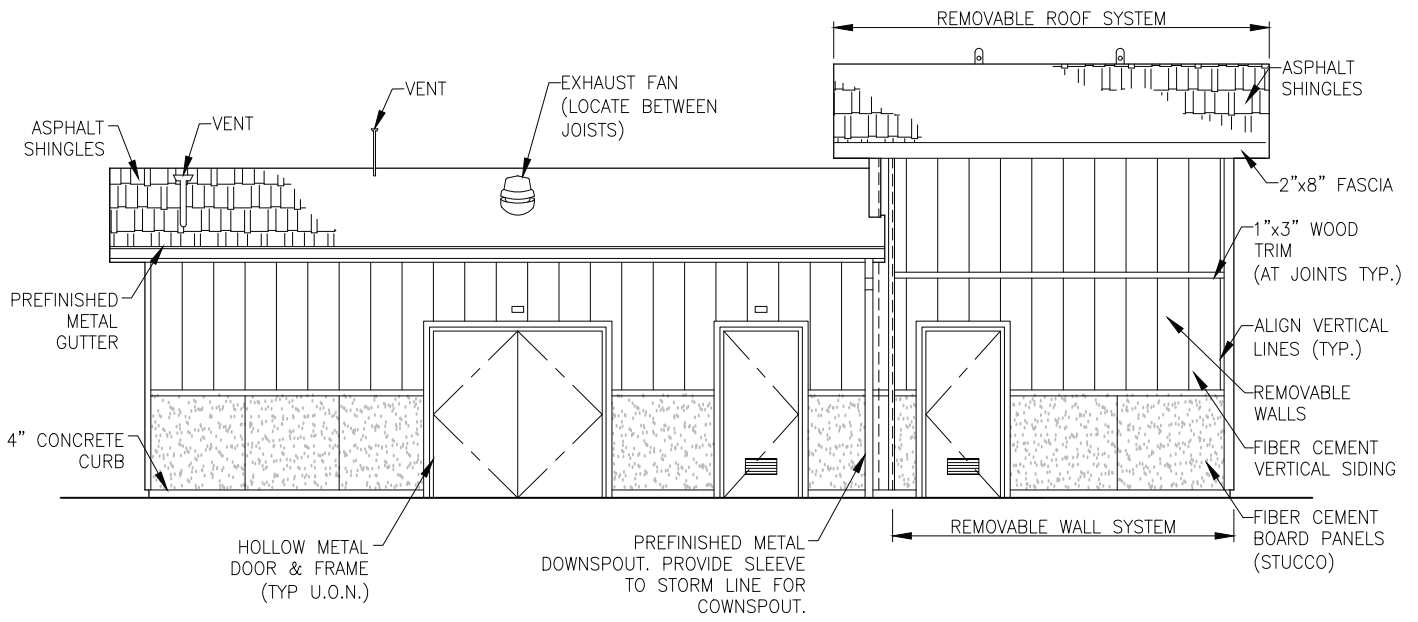

EAST ELEVATION

N.T.S.

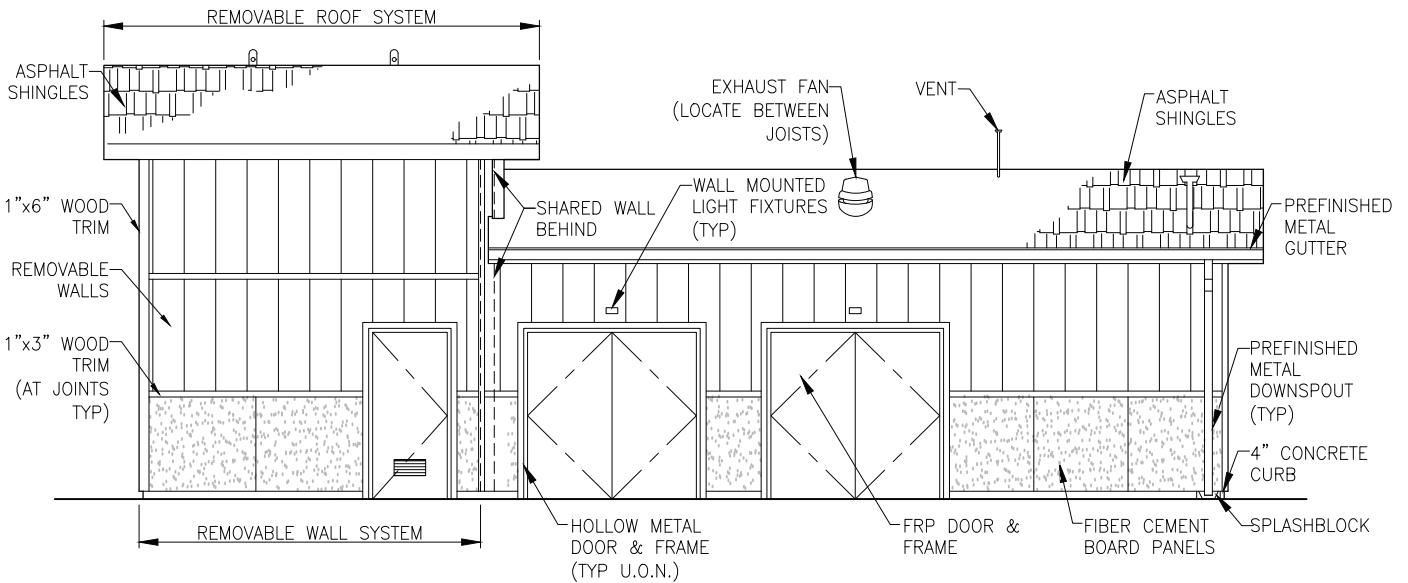

WEST ELEVATION

N.T.S.

APPROVED BY:
GSWC STANDARDS COMMITTEE

Alison Sweet

EDC MANAGER

6/15/26
DATE



Golden State
Water Company

A Subsidiary of American States Water Company

TITLE:

ARCHITECTURAL VIEWS OF
WELL BUILDING
WITH REMOVABLE ROOF

SCALE:
NONE

DATE:
07/31/23

REV
2024

STANDARD DWG NO.
W-20B

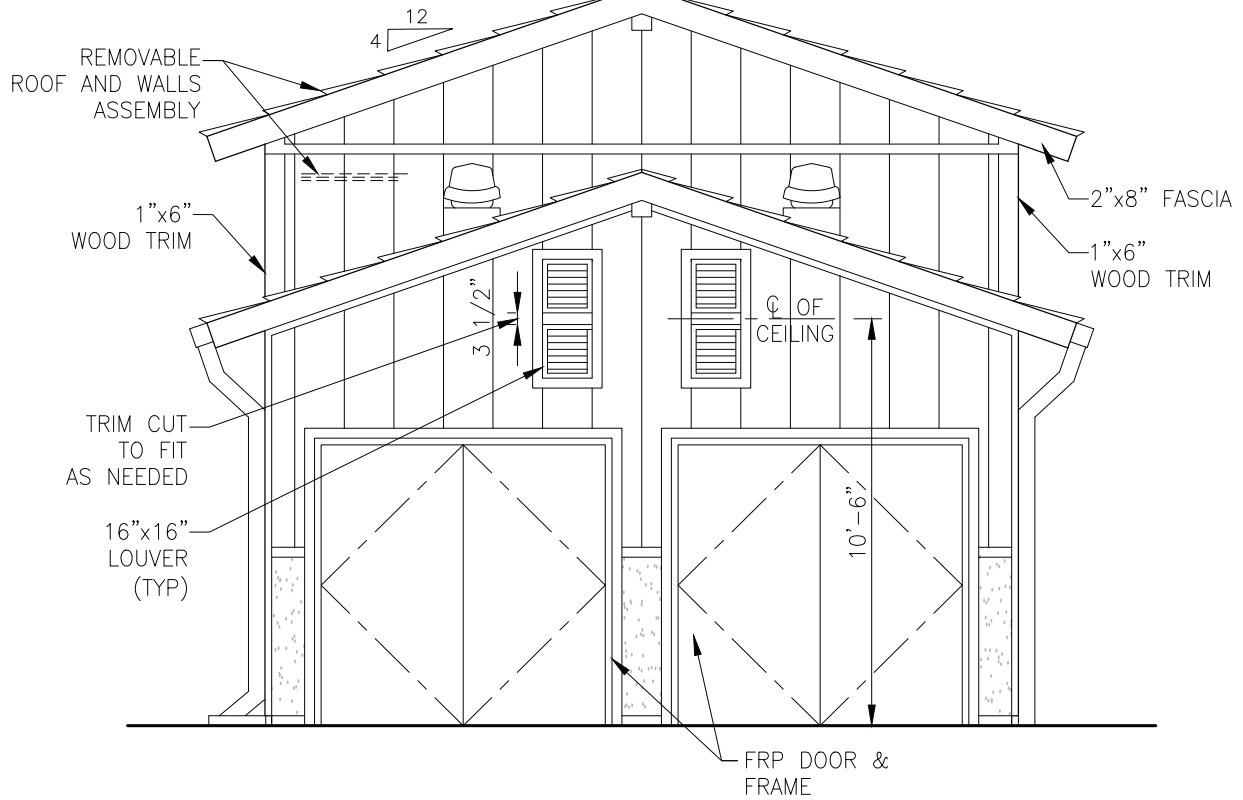

NORTH ELEVATION

N.T.S.

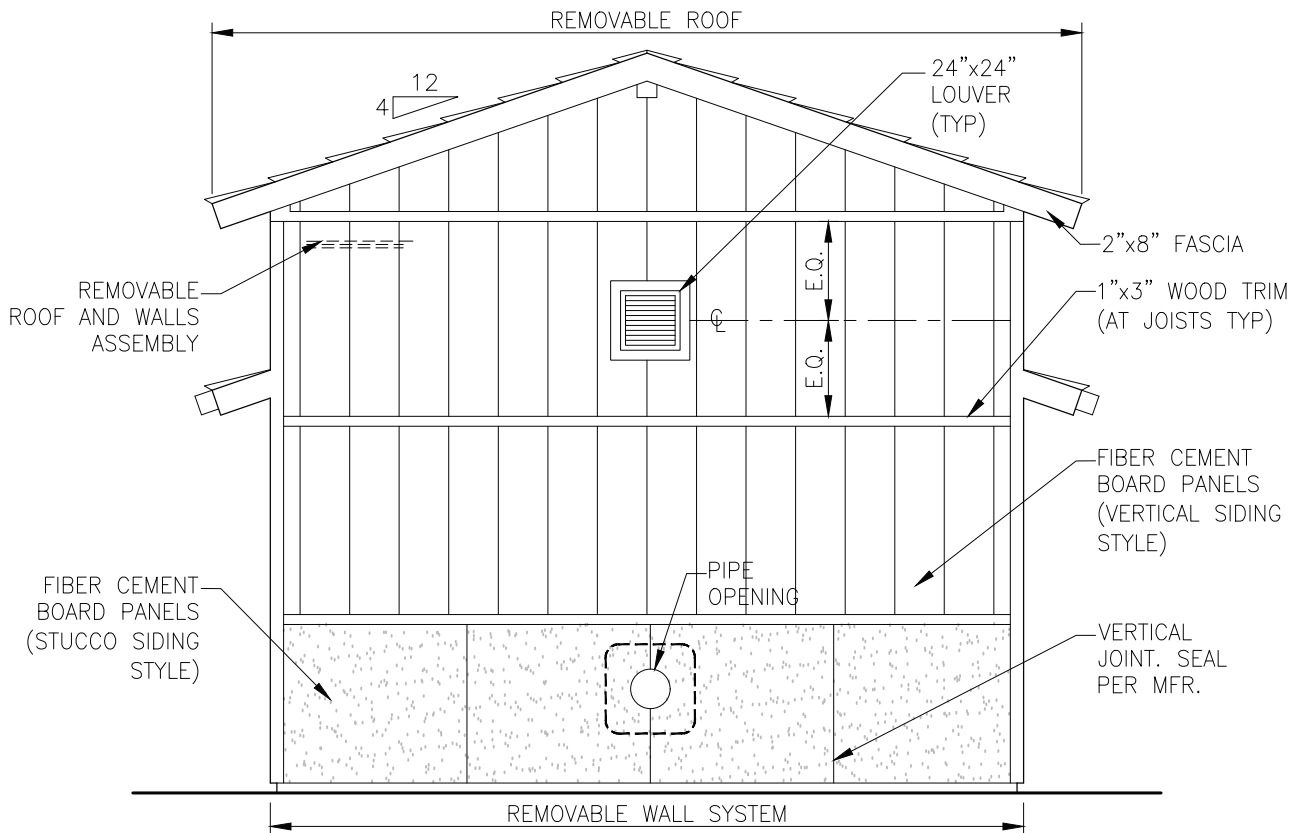

SOUTH ELEVATION

N.T.S.

APPROVED BY:
GSWC STANDARDS COMMITTEE

Alison Sweet

EDC MANAGER

6/15/26
DATE



Golden State
Water Company

A Subsidiary of American States Water Company

TITLE:

ARCHITECTURAL VIEWS OF
WELL BUILDING WITH
REMOVABLE ROOF

SCALE:
NONE

DATE:
07/31/23

REV
2024

STANDARD DWG NO.
W-20C

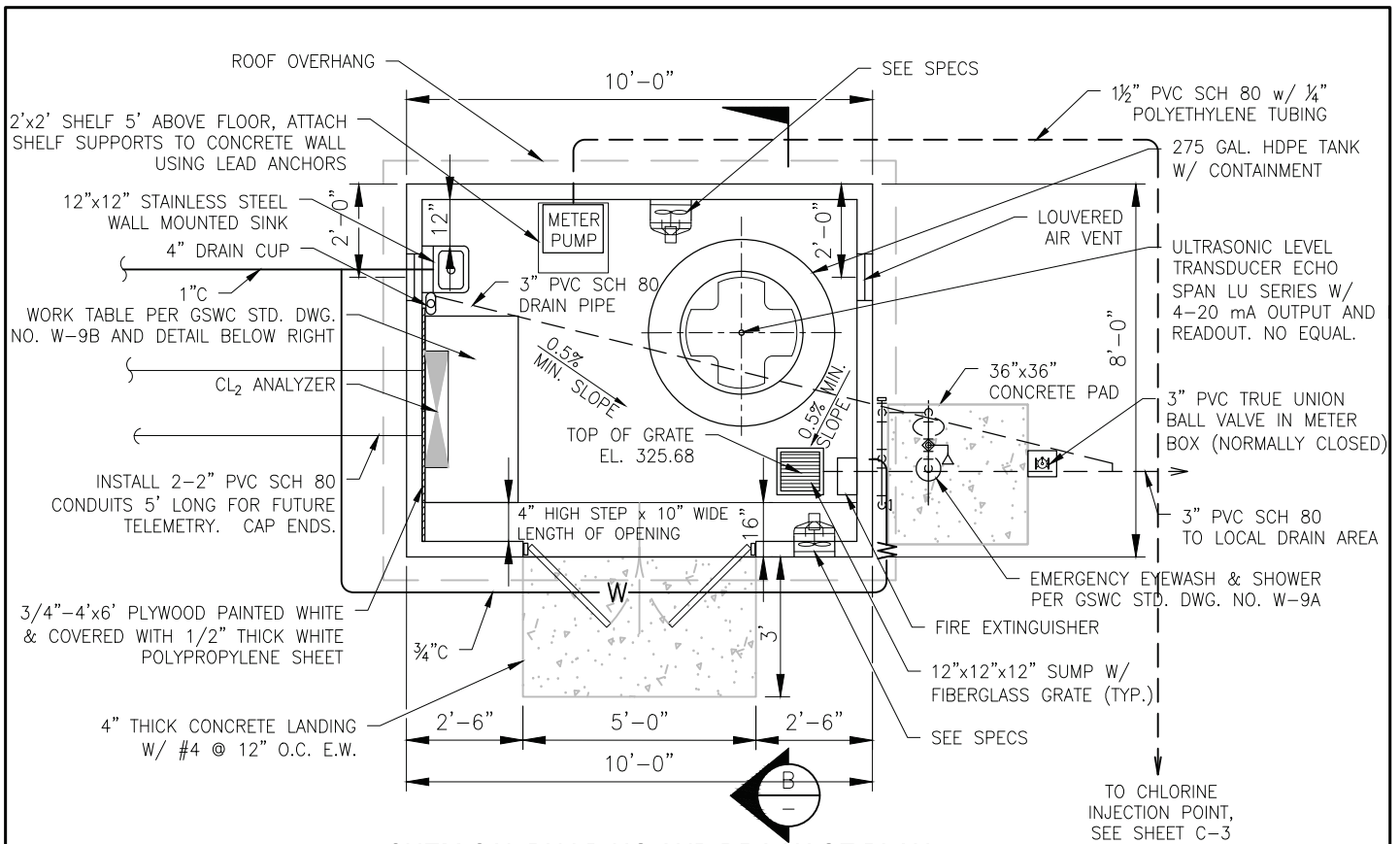

CHEMICAL BUILDING AND DRAINAGE PLAN

N.T.S.

N.T.S.

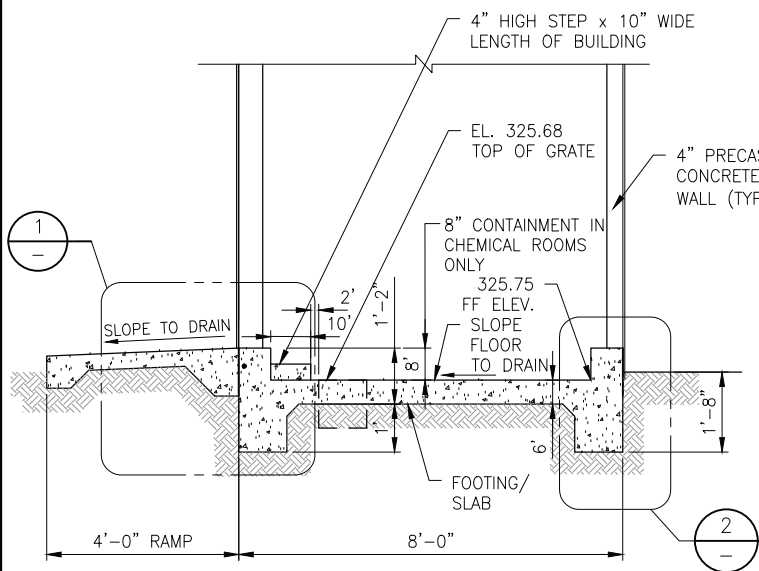

SECTION B

N.T.S.

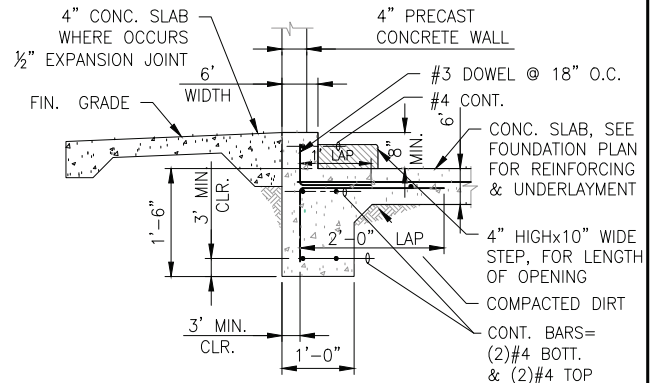

DETAIL 1

N.T.S.

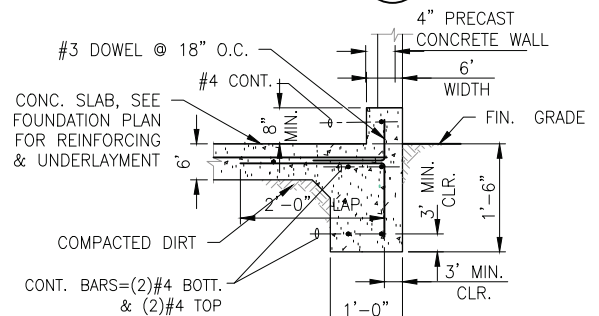

DETAIL 2

N.T.S.

APPROVED BY:
GSWC STANDARDS COMMITTEE

Alison Sweet

EDC MANAGER

6/15/26
DATE



Golden State
Water Company

A Subsidiary of American States Water Company

TITLE:

**PRECAST CONCRETE
DISINFECTION BUILDING
FLOOR AND FOUNDATION PLAN**

SCALE:	DATE:	REV	STANDARD DWG NO.
NONE	07/31/23	2024	W-21A

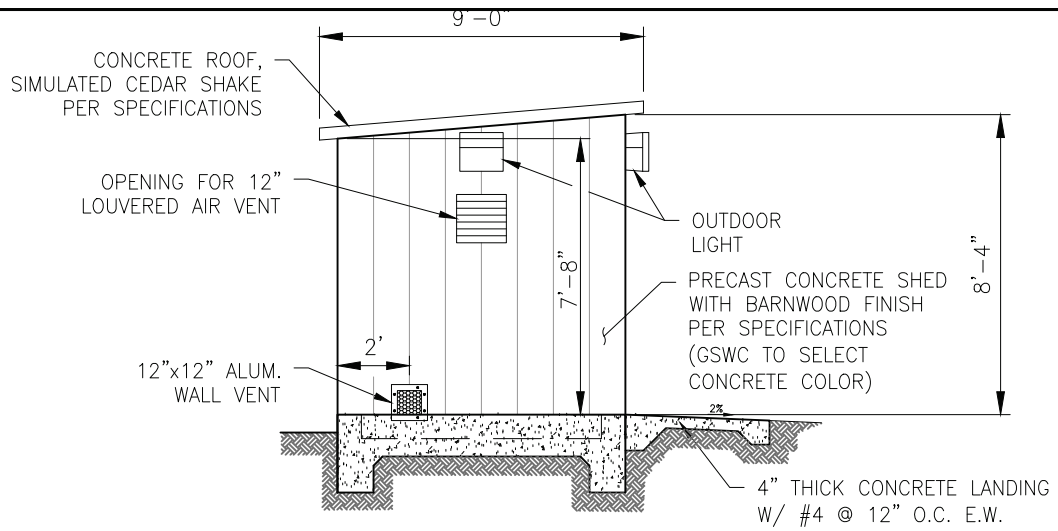

LEFT SIDE ELEVATION SECTION
N.T.S.

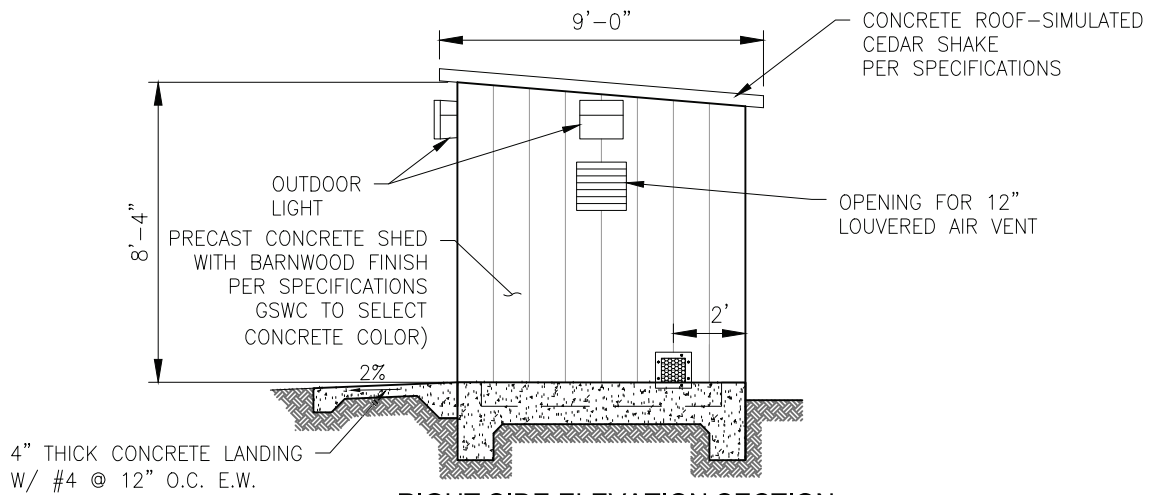

RIGHT SIDE ELEVATION SECTION
N.T.S.

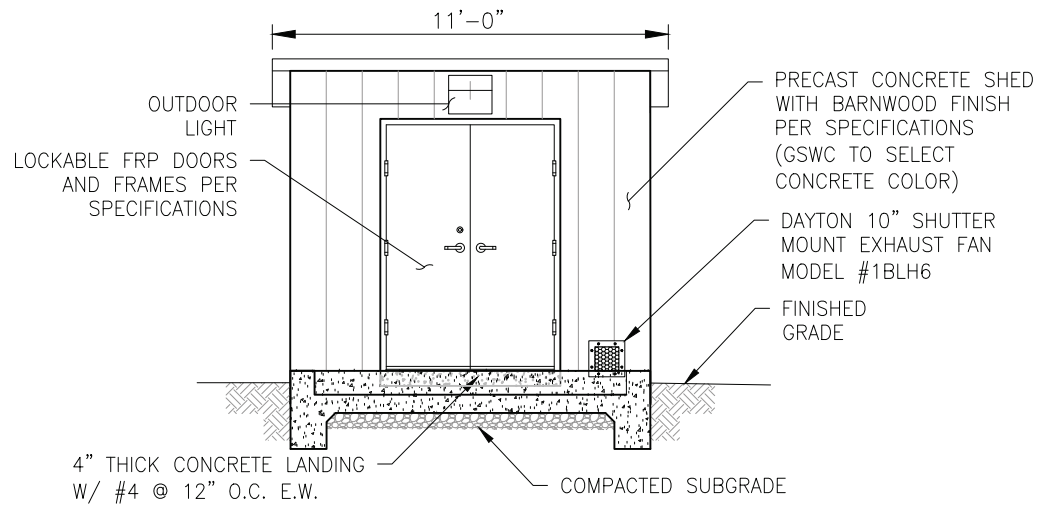

FRONT ELEVATION SECTION
N.T.S.

APPROVED BY:
GSWC STANDARDS COMMITTEE

Alison Sweet

EDC MANAGER

6/15/26
DATE



Golden State
Water Company

A Subsidiary of American States Water Company

TITLE:

**PRECAST CONCRETE
DISINFECTION BUILDING
ARCHITECTURAL VIEWS**

SCALE:
NONE

DATE:
07/31/23

REV
2024

STANDARD DWG NO.
W-21B

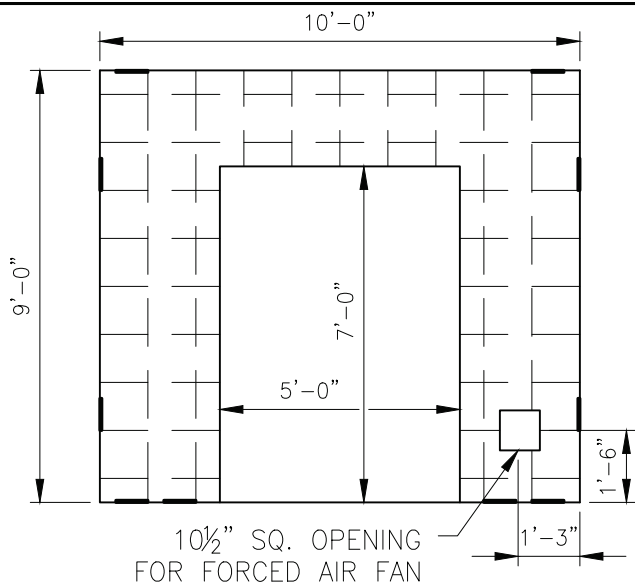

FRONT PANEL 4" THICK (1) REQUIRED

N.T.S.

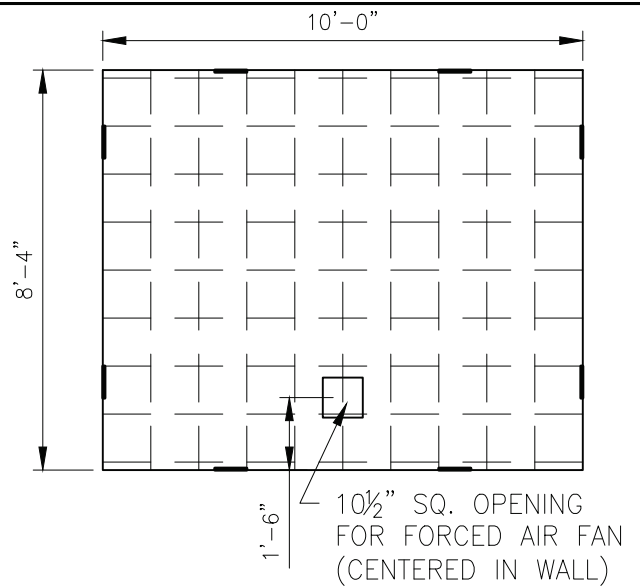

REAR PANEL 4" THICK (1) REQUIRED

N.T.S.

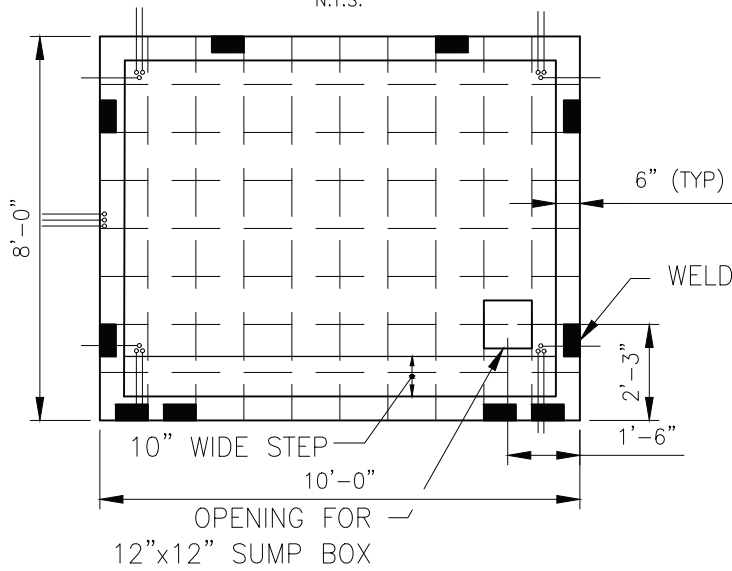

BUILDING FLOOR 6" THICK (1) REQUIRED

N.T.S.

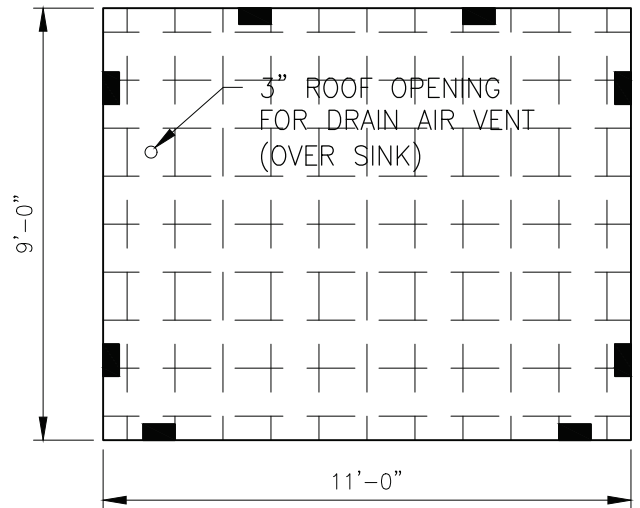

ROOF PANEL 4" THICK (1) REQUIRED

N.T.S.

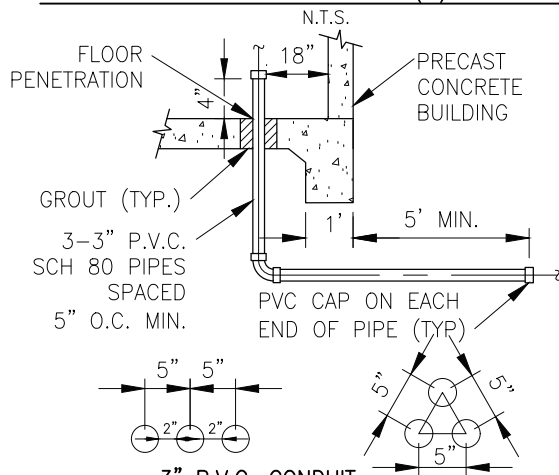

CONDUIT AND PENETRATION DETAIL

N.T.S.

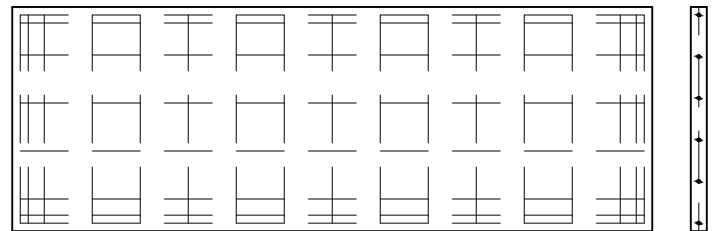

TYPICAL PANEL REINFORCING PLACEMENT

N.T.S.

APPROVED BY:
GSWC STANDARDS COMMITTEE

Alison Sweet

EDC MANAGER

6/15/26
DATE



Golden State
Water Company

A Subsidiary of American States Water Company

TITLE:

PRECAST CONCRETE
DISINFECTION BUILDING
ARCHITECTURAL VIEWS

SCALE:
NONE

DATE:
07/31/23

REV
2024

STANDARD DWG NO.
W-21C

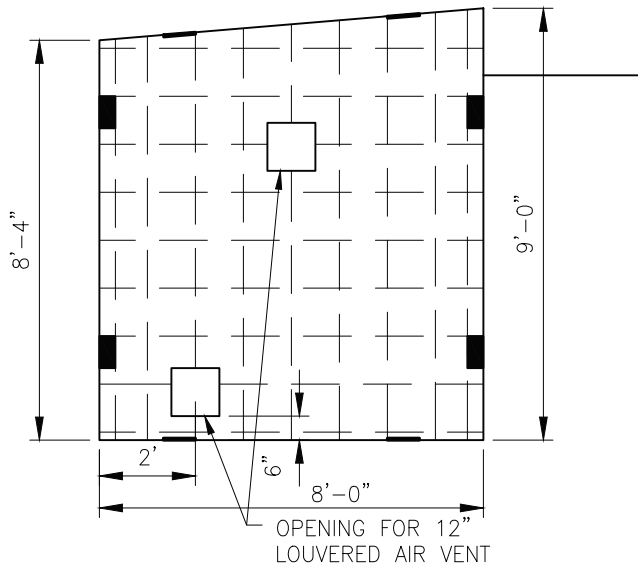

LEFT SIDE 4" THICK (1) REQUIRED
N.T.S.

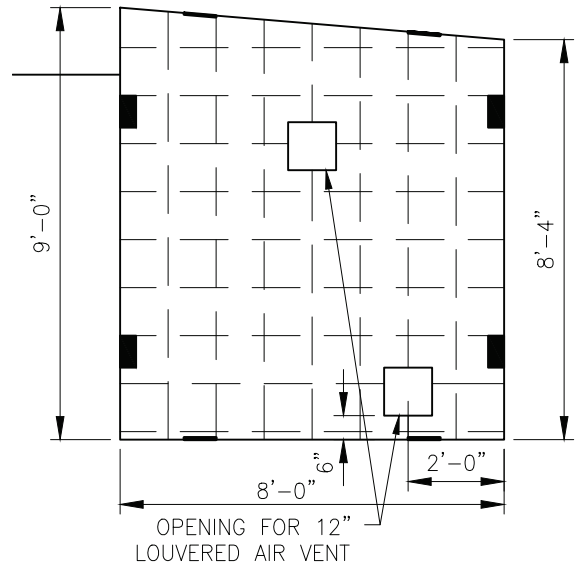

REAR PANEL 4" THICK (1) REQUIRED
N.T.S.

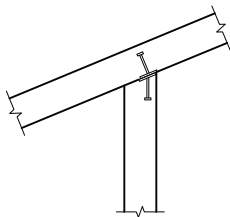

**TYP. WALL TO ROOF SLAB
WELDED CONNECTION DETAIL**
N.T.S.

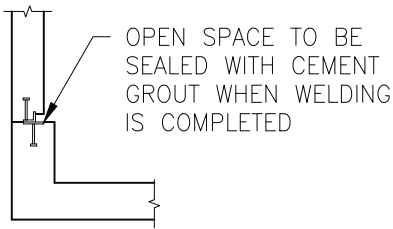

**TYP. WALL TO FLOOR SLAB
WELDED CONNECTION DETAIL**
N.T.S.

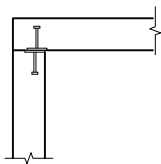

**TYP. WALL TO FLOOR SLAB
WELDED CONNECTION DETAIL**
N.T.S.

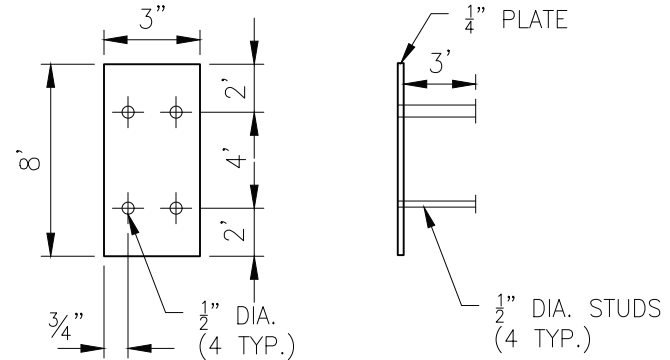

WELD PLATE DETAIL
N.T.S.

NOTES:

1. (2) #4 rebar at all panel edges and openings.
2. #4 rebar @ 12" o.c. each way (typ.).
3. Reinforcing steel: Grade 60, $f_y = 60$ ksi.
4. Concrete: footings and slab on grade: $f'_c = 4000$ psi.
All other concrete: $f'_c = 4000$ psi.
5. Adjust weld plates spacing for openings. Match weld plates on floor panel to wall panels, and roof panels to wall panels.
6. Two weld plates at each wall panel connection.
7. Reinforcing steel placed in panels, 2" from panel surface.
8. After construction all weld plates shall be covered by cement grout to protect from corrosion.
9. Install two 1/2-inch wide beads of butyl rubber sealant between wall panels and top rim of building floor and between top of walls and roof panel prior to setting wall panels and roof. clean any excess from interior or exterior vertical surfaces.
10. Floor sloped 0.5% to floor drain.

APPROVED BY:
GSWC STANDARDS COMMITTEE

Alison Sweet

EDC MANAGER

6/15/26
DATE



Golden State
Water Company

A Subsidiary of American States Water Company

TITLE:

PRECAST CONCRETE
DISINFECTION BUILDING
ARCHITECTURAL VIEWS

SCALE:
NONE

DATE:
07/31/23

REV
2024

STANDARD DWG NO.
W-21D

Section 5

Water Tanks

- ① TANK INLET PIPING (SEE STD. DWG. T-2)
- ② 12" OVERFLOW PIPE (SEE STD. DWG. T-4)
- ③ 4'x8' CONCRETE VAULT (SEE STD. DWG. T-6)
- ④ 1" SCH 40 PVC ELECTRICAL CONDUIT
- ⑤ 4" SCH 40 PVC ELECTRICAL CONDUIT
- ⑥ OUTLET PIPING (SEE STD. DWG. T-3)
- ⑦ WATER LEVEL INDICATOR (SEE STD. DWG. T-17)
- ⑧ FLANGED ROOF HATCH (SEE STD. DWG. T-12)
- ⑨ SENSING AND SAMPLING CONNECTION (SEE STD. DWG. T-16)
- ⑩ LARGE MANWAY AND DRAIN PIPE (SEE STD. DWG. T-5)
- ⑪ ROOF HATCH (SEE STD. DWG. T-10)
- ⑫ STAIRS (SEE STD. DWG. T-8)
- ⑬ 36" ACCESS MANWAY (SEE STD. DWG. T-7)
- ⑭ CENTER ROOF VENT (SEE STD. DWG. T-13)
- ⑮ TRANSITION COUPLING (PVC OR DIP TO STEEL)
- ⑯ CONCRETE ALLEY GUTTER (SEE STD. DWG. C-6)
- ⑰ 12" PVC AWWA C900 CLASS 235
- ⑱ TIE-OFF ANCHORS AROUND ROOF VENT (SEE STD. DWG. T-9)

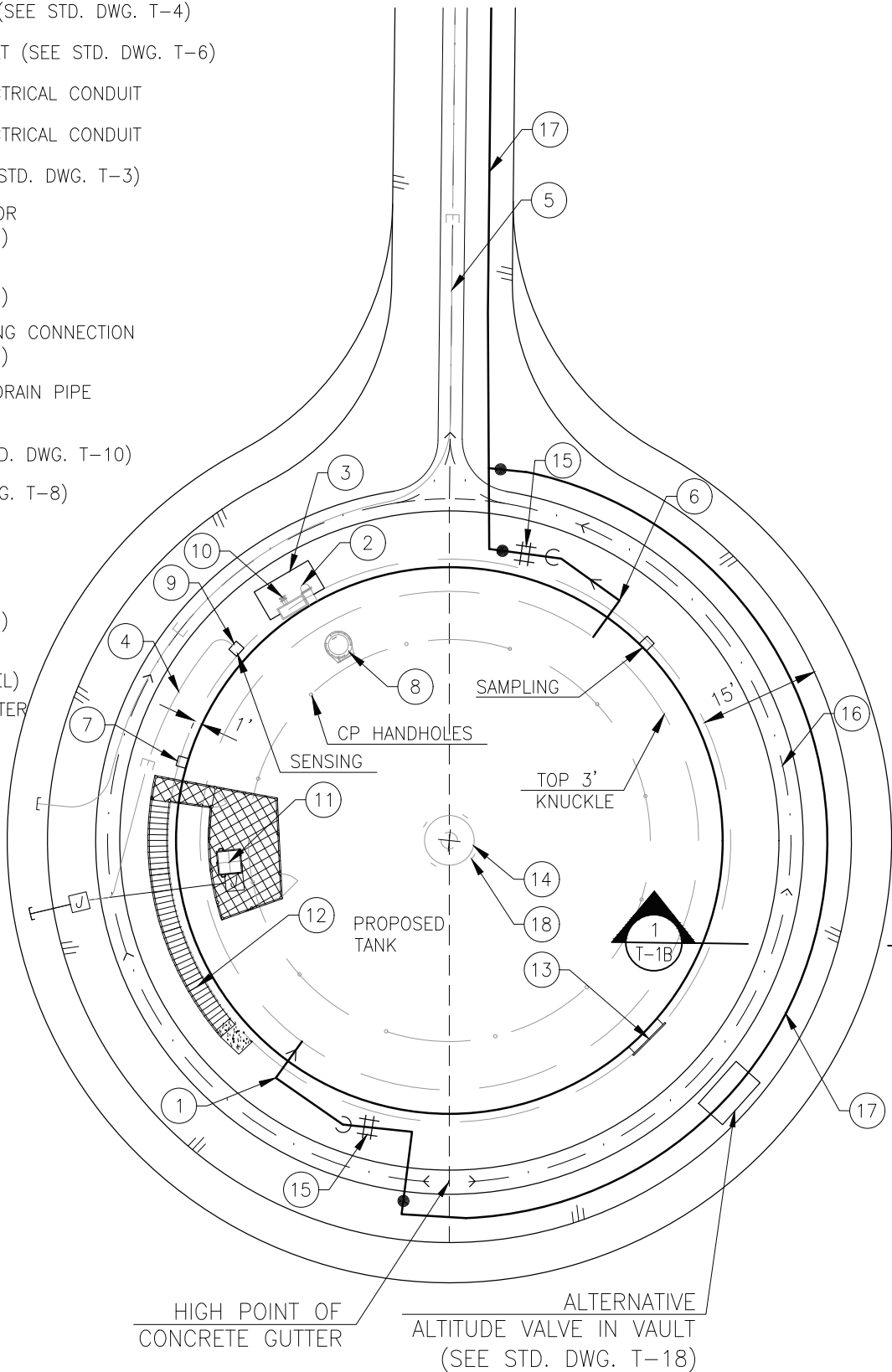

APPROVED BY:
GSWC STANDARDS COMMITTEE

Alison Sweet

EDC MANAGER

6/15/26
DATE



Golden State
Water Company

A Subsidiary of American States Water Company

TITLE:

WELDED STEEL RESERVOIR
TYPICAL SITE PLAN

SCALE:	DATE:	REV	STANDARD DWG NO.
NONE	07/31/23	2024	T-1A

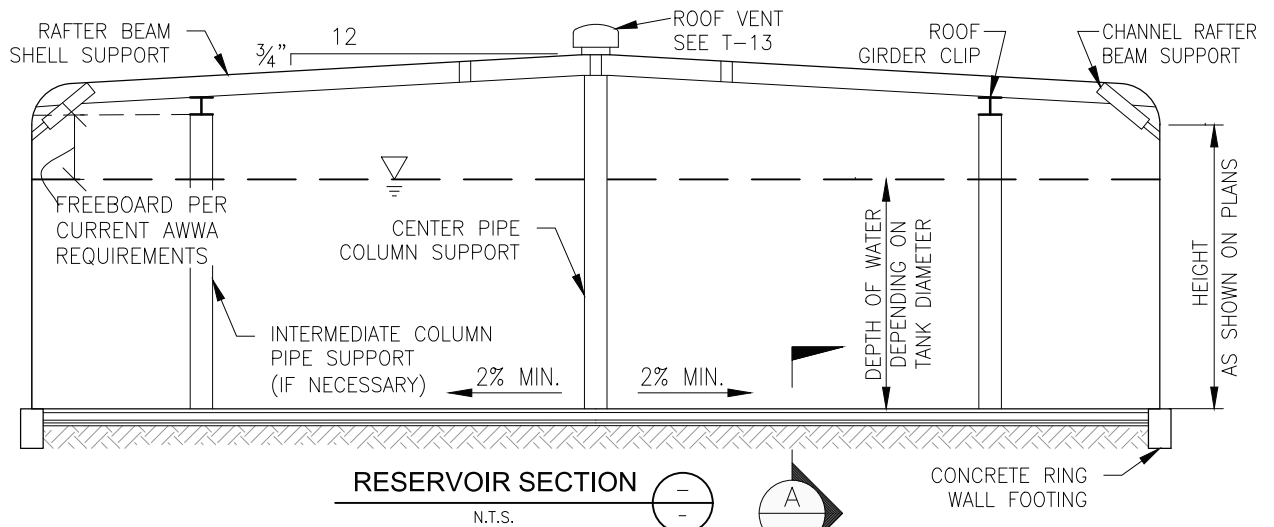

RESERVOIR SECTION

N.T.S.

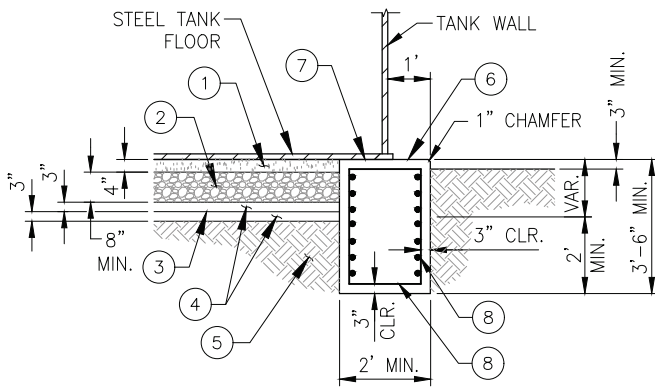

CONCRETE RING WALL FOOTING

N.T.S.

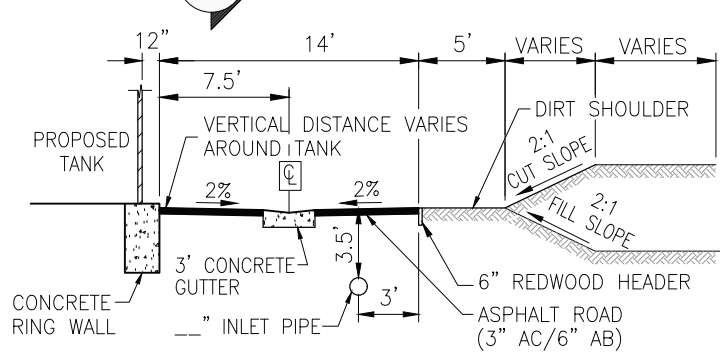

SITE GRADING AND PAVING SECTION

N.T.S.

NOTES:

1. For bidding purposes assume 5-foot overexcavating and recompaction underneath the bottom of the ringwall and 5-feet beyond the ringwall with 12 inch layer of structural bedding material compact to 95%.
2. Concrete grade ring shall be constructed in one continuous concrete placement, no construction joints are allowed. detail is for bidding purposes only.
3. Contractor shall submit concrete ringwall design calculations and reinforcing requirements. Ringwall shall be constructed per AWWA-D100-21 requirements and geotechnical report.
4. Provide concrete cylinder test.

LIST OF MATERIALS

①	Compacted oil sand w/ 6-8 lbs. of SC-800 liquid asphalt per 100 lbs. of sand
②	3/8" crushed rock per SSPWC section 200-1.2
③	Impermeable membrane, Lap up and over ringwall a min. of 6".
④	Sand (SE30)
⑤	Select granular material per soils engineer's recommendations
⑥	Steel trowel finish top (to be level with 1/8" in any 30" and 1/4" overall)
⑦	Continuous cellular fiber joint filler between floor plate and top of ring wall-1/2" thick
⑧	Rebar per plans

APPROVED BY:
GSWC STANDARDS COMMITTEE

Alison Sweet

EDC MANAGER

6/15/26
DATE



Golden State
Water Company

A Subsidiary of American States Water Company

TITLE:

**WELDED STEEL RESERVOIR
TYPICAL SECTION VIEW**

SCALE:
NONE

DATE:
07/31/23

REV
2024

STANDARD DWG NO.
T-1B

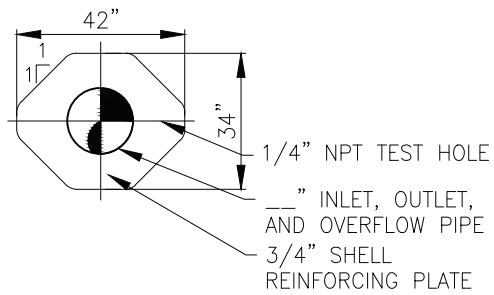

SHELL REINFORCING PLATE

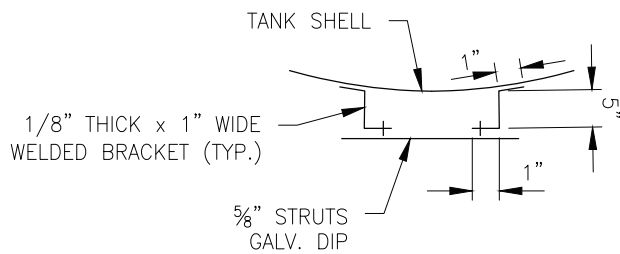

**TELEMETRY CONDUIT
WELDED BRACKET DETAIL**

N.T.S.
(LOCATIONS TO BE SHOWN ON THE PLANS)

APPROVED BY:
GSWC STANDARDS COMMITTEE

Alison Sweet

EDC MANAGER

6/15/26
DATE



Golden State
Water Company

A Subsidiary of American States Water Company

TITLE:

SHELL REINFORCING PLATE

SCALE:
NONE

DATE:
07/31/23

REV
2024

STANDARD DWG NO.
T-1C

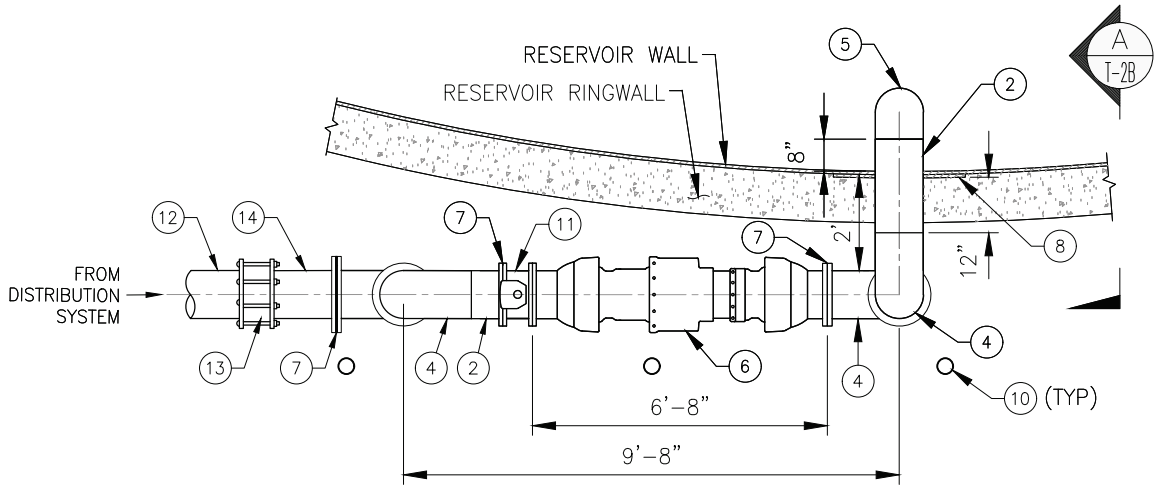

PLAN VIEW INLET PIPING DETAIL 1
N.T.S.

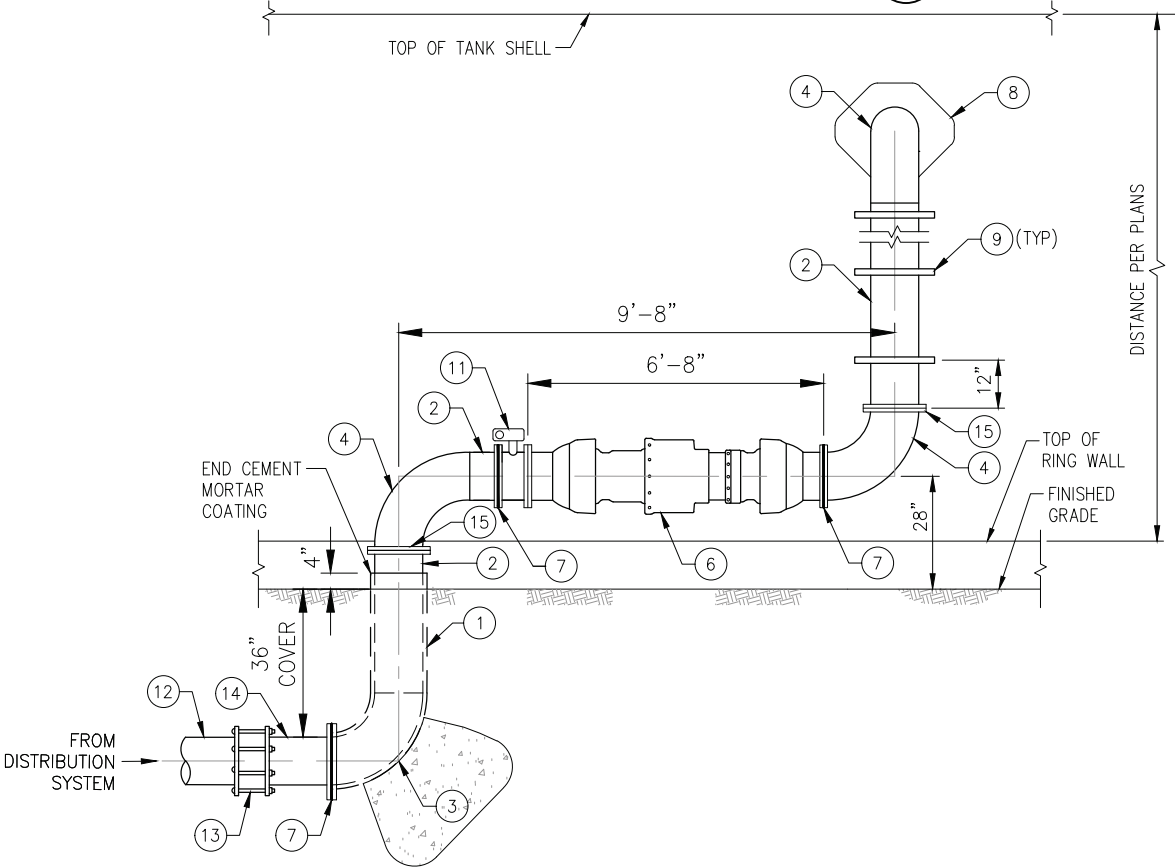

FRONT VIEW INLET PIPING DETAIL 2
N.T.S.

NOTES:

1. See GSWC std. drawing T-2B for construction notes.
2. Pipe diameter to be called out in drawings.
3. All steel pipe below grade shall be cement mortar coated. All steel pipe above grade shall be painted to match tank.
4. Dimensions shown are for 12" pipe. Larger or smaller pipe will require modifications to these dimensions.

APPROVED BY:
GSWC STANDARDS COMMITTEE

Alison Sweet
EDC MANAGER

6/15/26
DATE



TITLE: INLET CONNECTION			
SCALE: NONE	DATE: 07/31/23	REV 2024	STANDARD DWG NO. T-2A

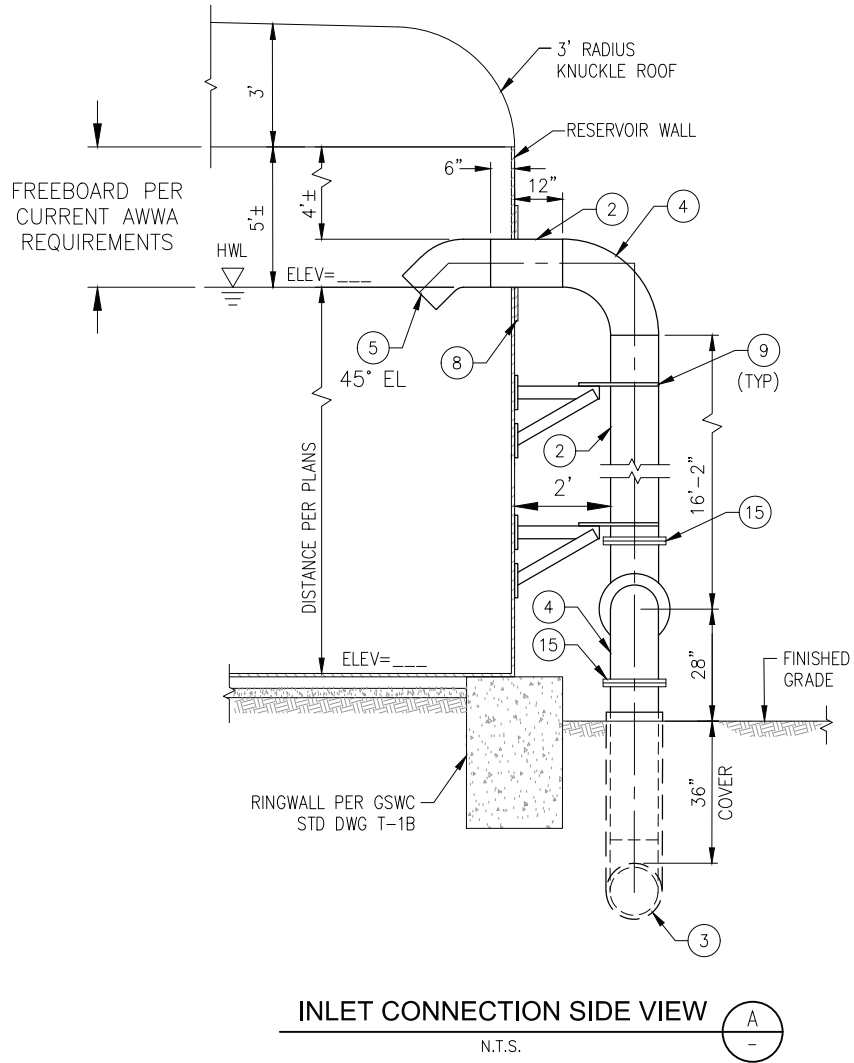

INLET CONNECTION CONSTRUCTION NOTES:

- | | |
|---|--|
| <p>① — INSTALL WELDED STEEL PIPE, SCH. 40, CMC AND EPOXY LINED.</p> <p>② — INSTALL WELDED STEEL PIPE, SCH. 40, EPOXY LINED.</p> <p>③ — INSTALL WELDED STEEL 90° L.R. ELBOW, SCH. 40, CMC AND EPOXY LINED.</p> <p>④ — INSTALL WELDED STEEL 90° L.R. ELBOW, SCH. 40, EPOXY LINED.</p> <p>⑤ — INSTALL WELDED STEEL 45° ELBOW, SCH. 40, EPOXY LINED.</p> <p>⑥ — INSTALL FLEX-TEND FORCE BALANCED EXPANSION JOINT FROM EBAA IRON.</p> <p>⑦ — INSTALL SLIP-ON WELDED FLANGE W/INSULATING GASKET.</p> <p>⑧ — INSTALL SHELL REINFORCING PLATE PER GSWC STD. DWG. T-2C AND AWWA D-100.</p> | <p>⑨ — INSTALL SUPPORT BRACKET PER GSWC STD. DWG. T-2C.</p> <p>⑩ — INSTALL VEHICLE BARRIER PER GSWC STD. DWG. C-9.</p> <p>⑪ — INSTALL BUTTERFLY VALVE, F.E.</p> <p>⑫ — INSTALL DUCTILE IRON PIPE.</p> <p>⑬ — INSTALL FLEXIBLE COUPLING (FULLY RESTRAINED)</p> <p>⑭ — INSTALL DUCTILE IRON ADAPTER, F.E.xP.E.</p> <p>⑮ — INSTALL SLIP-ON WELDED FLANGE.</p> |
|---|--|

APPROVED BY:
GSWC STANDARDS COMMITTEE

Alison Sweet

EDC MANAGER

6/15/26
DATE



Golden State
Water Company

A Subsidiary of American States Water Company

TITLE:

**INLET CONNECTION
KNUCKLE ROOF TANK**

SCALE:
NONE

DATE:
07/31/23

REV
2024

STANDARD DWG NO.
T-2B

NOTES:

1. See GSWC std. dwg. T-2B for construction notes.
2. Pipe diameter to be called out in drawings.
3. All steel pipe below grade shall be cement mortar coated. All steel pipe above grade shall be painted to match tank.
4. Dimensions shown are for 12" pipe. Larger or smaller pipe will require modifications to these dimensions.

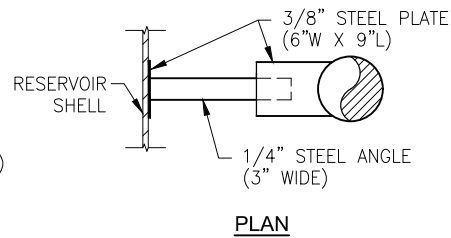
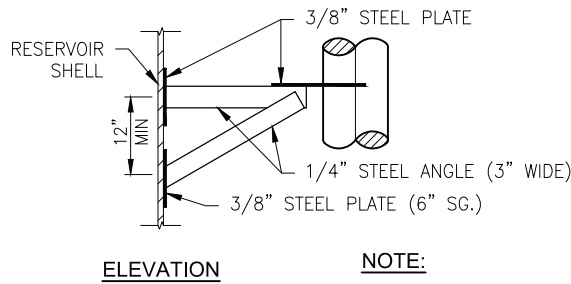
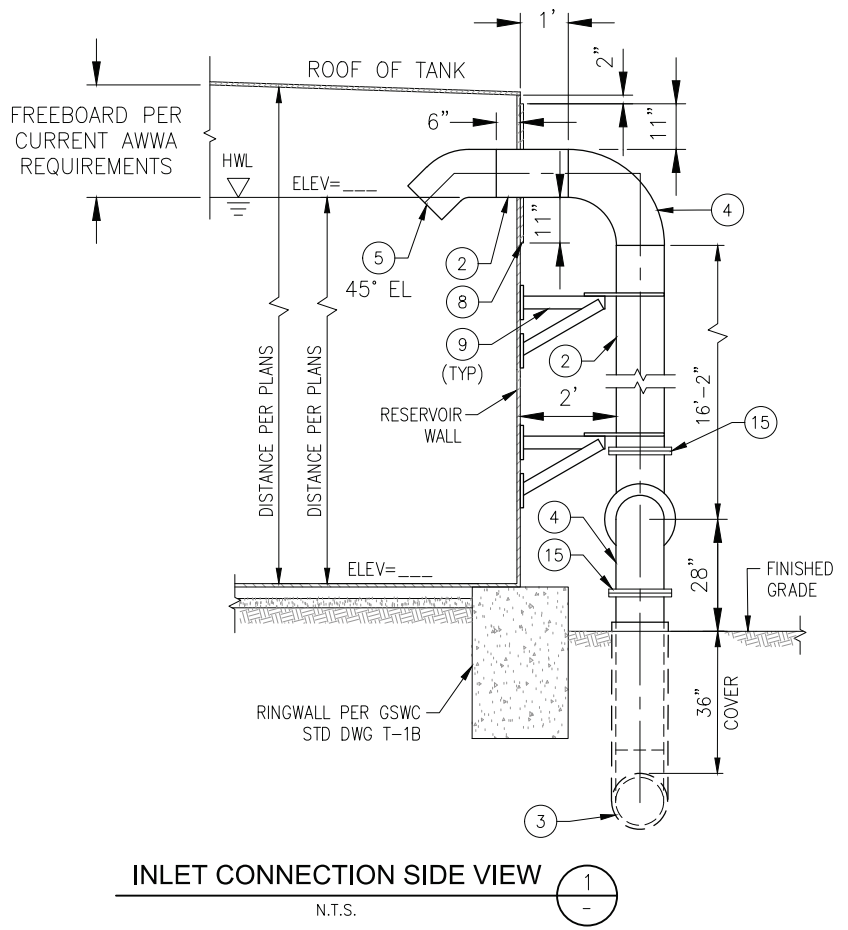

NOTE:

Fully weld steel plates to shell and pipe, weld steel angles to each other and steel plate.

SUPPORT BRACKET DETAIL (2)
N.T.S.

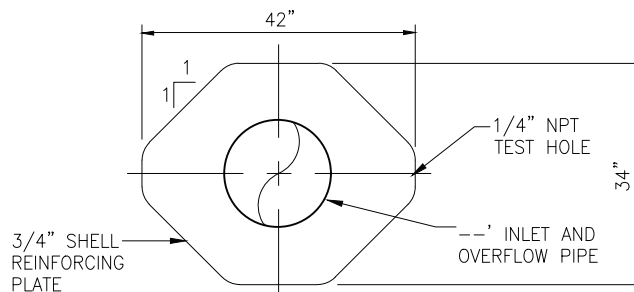

REINFORCING PLATE DETAIL (3)
N.T.S.

APPROVED BY:
GSWC STANDARDS COMMITTEE

Alison Sweet

EDC MANAGER

6/15/26
DATE



Golden State
Water Company

A Subsidiary of American States Water Company

TITLE:

**INLET CONNECTION
FLAT ROOF TANK
AND MISC DETAILS**

SCALE:	DATE:	REV	STANDARD DWG NO.
NONE	07/31/23	2024	T-2C

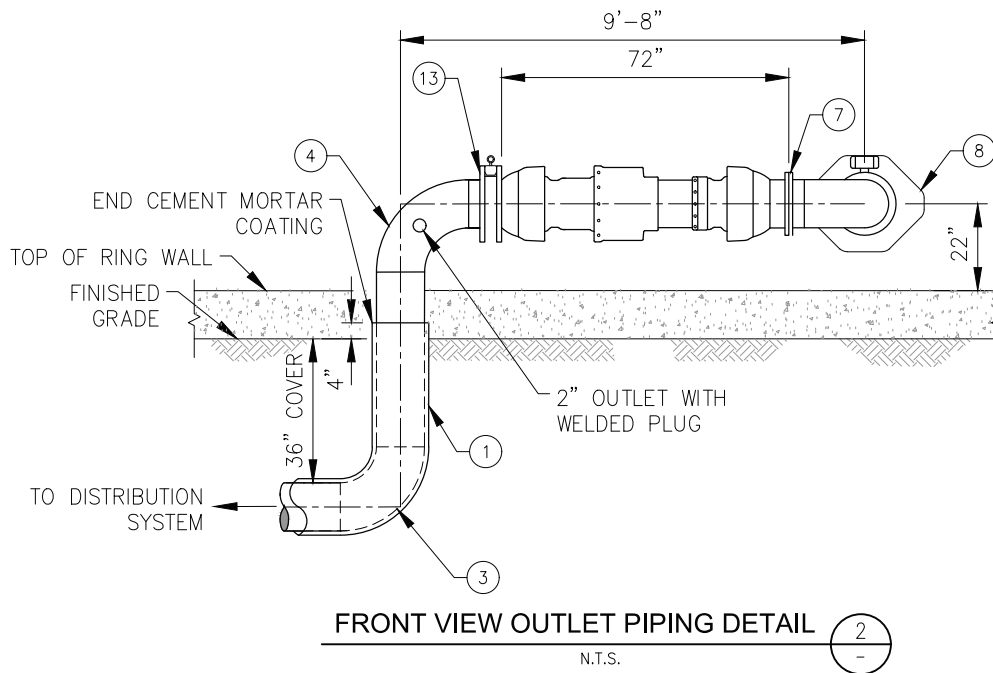
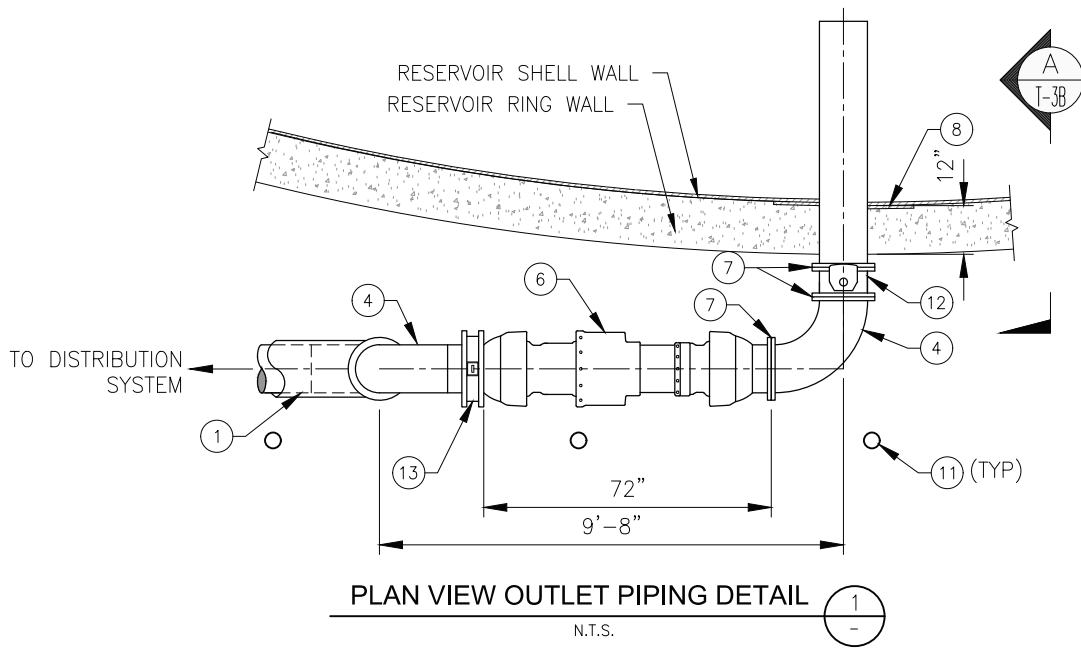

NOTES:

1. See GSWC STD. DWG. T-3B for construction notes.
2. Pipe diameter to be called out in drawings.
3. All steel pipe below grade shall be cement mortar coated. all steel pipe above grade shall be painted to match tank.
4. Dimensions shown are for 12" pipe. larger or smaller pipe will require modifications to these dimensions.

APPROVED BY:
GSWC STANDARDS COMMITTEE

Alison Sweet

EDC MANAGER

6/15/26
DATE



Golden State
Water Company

A Subsidiary of American States Water Company

TITLE:

OUTLET CONNECTION

SCALE:
NONE

DATE:
07/31/23

REV
2024

STANDARD DWG NO.
T-3A

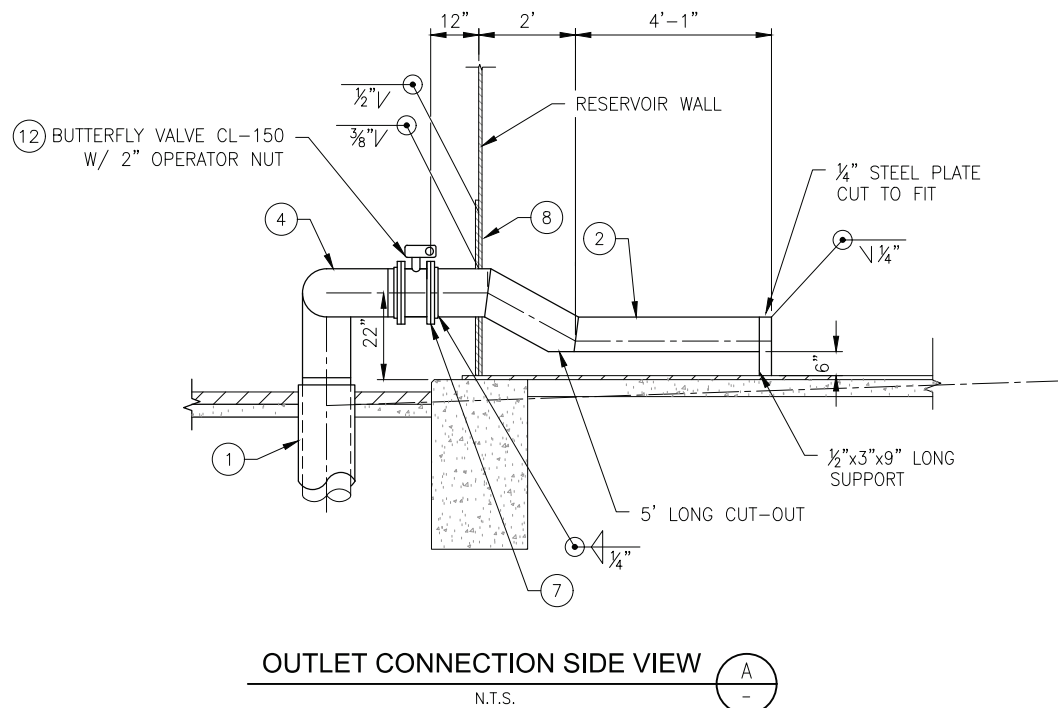
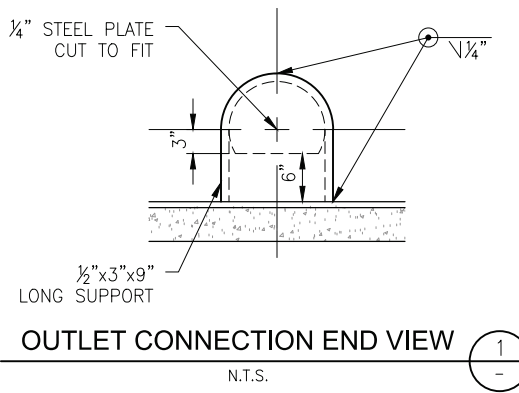

OUTLET CONNECTION CONSTRUCTION NOTES:

- | | |
|--|--|
| <p>① — INSTALL WELDED STEEL PIPE, SCH. 40, CMC & EPOXY LINED.</p> <p>② — INSTALL WELDED STEEL PIPE, SCH. 40, EPOXY LINED.</p> <p>③ — INSTALL WELDED STEEL 90° L.R. ELBOW, SCH. 40, CMC & EPOXY LINED.</p> <p>④ — INSTALL WELDED STEEL 90° L.R. ELBOW, SCH. 40, EPOXY LINED.</p> <p>⑤ — INSTALL WELDED STEEL 45° ELBOW, SCH. 40, EPOXY LINED.</p> <p>⑥ — INSTALL FLEX-TEND FORCE BALANCED EXPANSION JOINT FROM EBAA IRON.</p> <p>⑦ — INSTALL SLIP-ON WELDED FLANGE.</p> <p>⑧ — INSTALL SHELL REINFORCING PLATE PER GSWC STD. DWG. T-1 AND AWWA D-100.</p> | <p>⑨ — INSTALL SUPPORT BRACKET PER GSWC STD. DWG. T-6.</p> <p>⑩ — INSTALL 1" WELDED THREAD-O-LET, 1" BALL VALVE AND 1" PLUG FOR SAMPLING.</p> <p>⑪ — INSTALL VEHICLE BARRIER PER GSWC STD. DWG. C-9.</p> <p>⑫ — INSTALL BUTTERFLY VALVE, FE.</p> <p>⑬ — INSTALL WAFER SWING CHECK, RITE SERIES 210.</p> <p>⑭ — INSTALL 1" WELDED THREAD-O-LET, 1" BALL VALVE AND 1" PLUG FOR SAMPLING.</p> |
|--|--|

APPROVED BY:
GSWC STANDARDS COMMITTEE

Alison Sweet

EDC MANAGER

6/15/26
DATE



Golden State
Water Company

A Subsidiary of American States Water Company

TITLE:

OUTLET CONNECTION

SCALE:	DATE:	REV	STANDARD DWG NO.
NONE	03/31/26	2026	T-3B

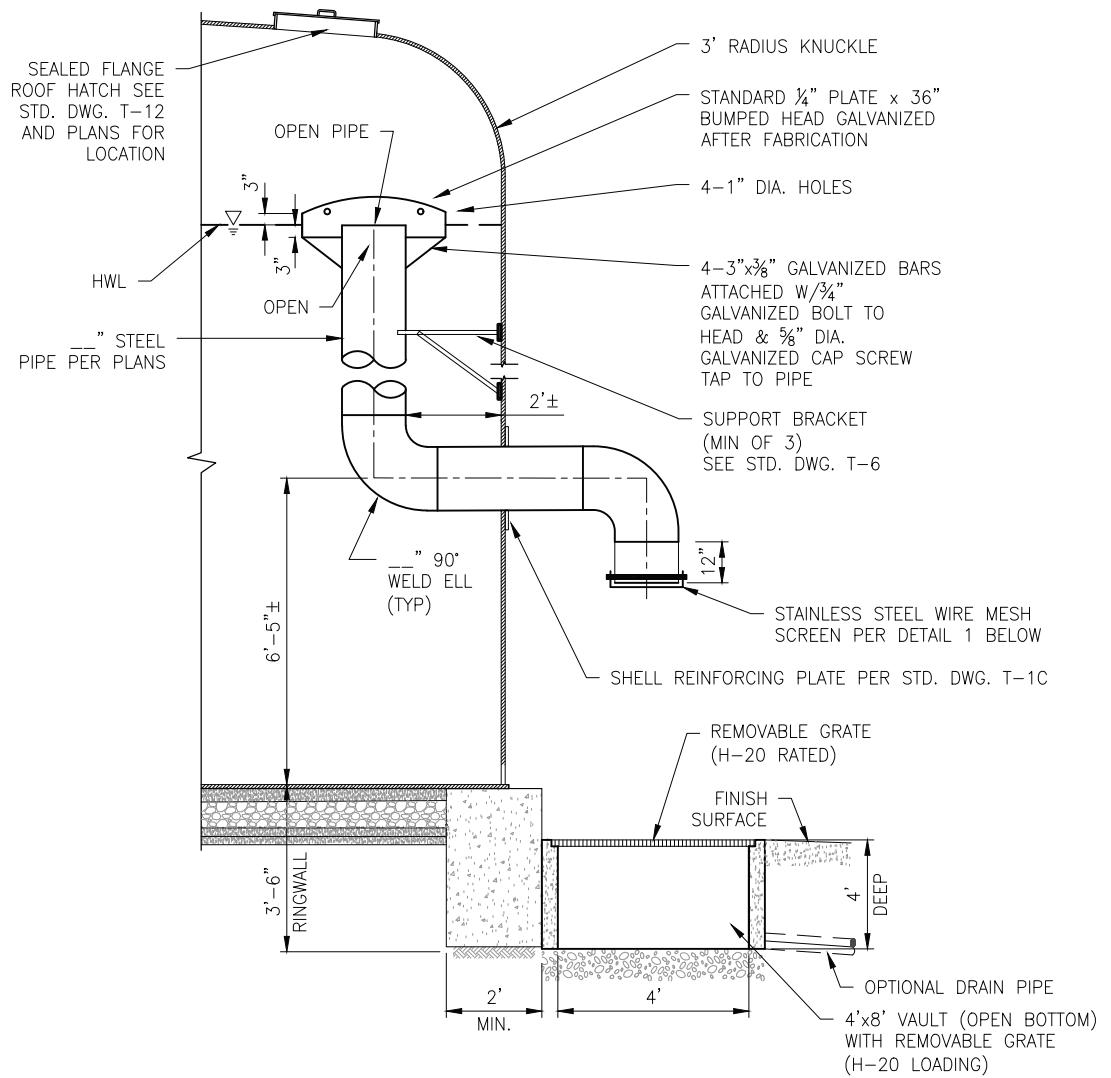

OVERFLOW PIPE SIDE VIEW (A)
N.T.S.

NOTES:

1. See plans for size of overflow pipe.
2. See STD. DWG. T-5 and T-6 for front and plan view and to see complete assembly with Large Access Manway.

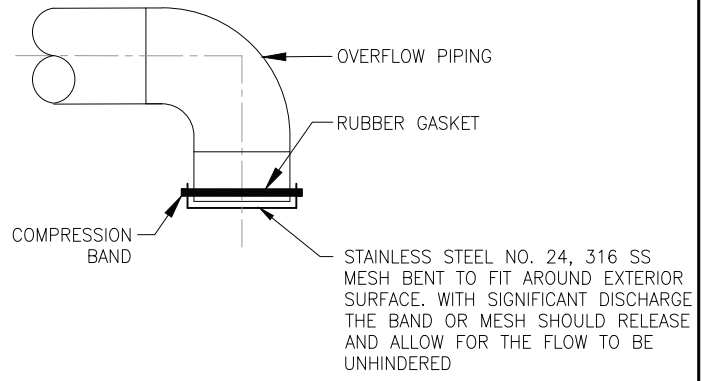

STAINLESS STEEL SCREEN DETAIL (1)
N.T.S.

APPROVED BY:
GSWC STANDARDS COMMITTEE
Alison Sweet
EDC MANAGER
6/15/26
DATE



TITLE: OVERFLOW PIPE			
SCALE: NONE	DATE: 04/20/26	REV 2026	STANDARD DWG NO. T-4

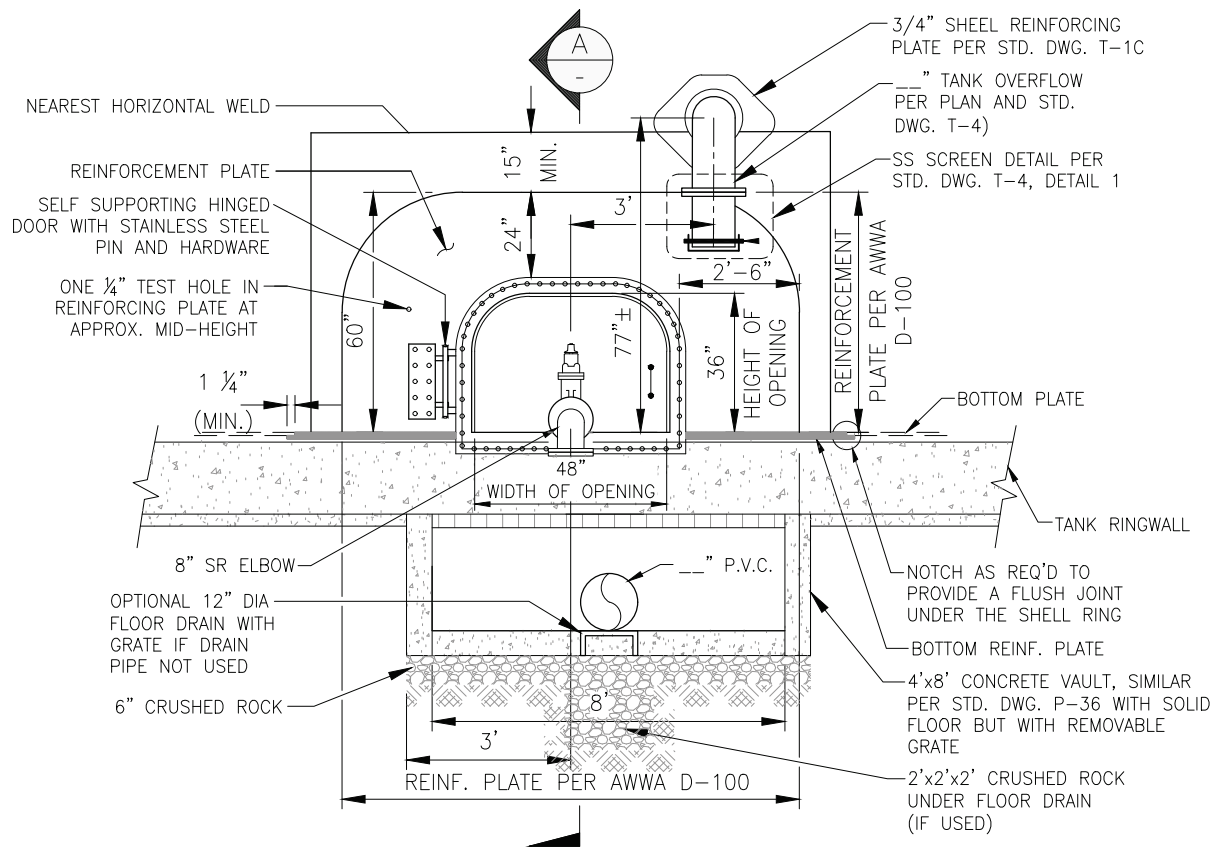

LARGE ACCESS MANWAY WITH CLEAN-OUT FRONT VIEW

1
-

N.T.S.

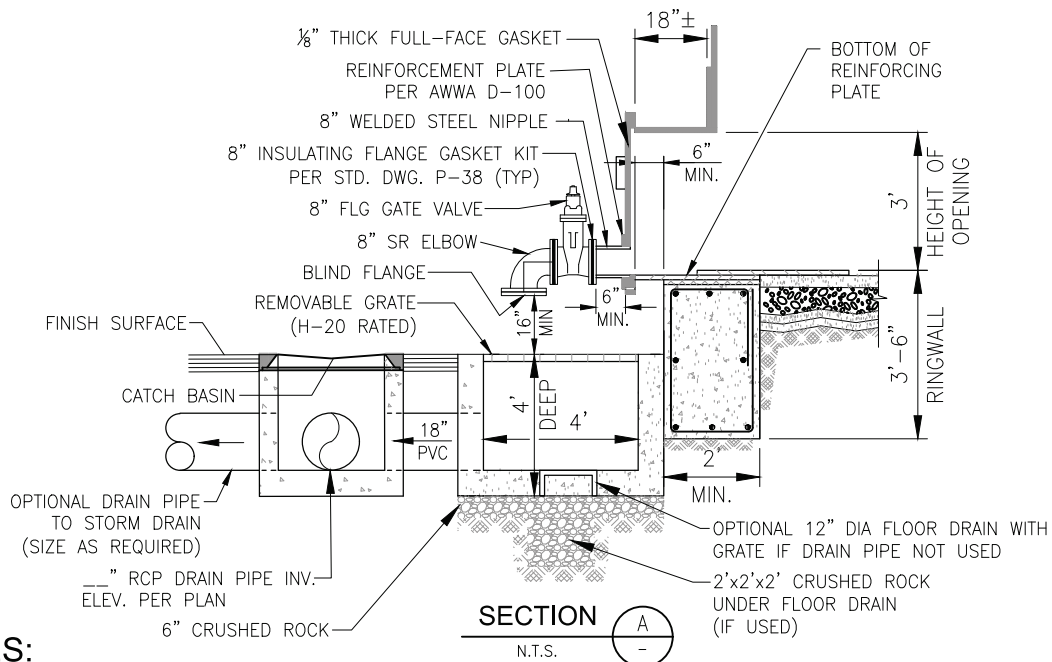

SECTION A

N.T.S.

NOTES:

1. Top of concrete ringwall will need to be notched to suit bottom reinforcing plate and flush-type cleanout manhole. Contractor shall verify with tank manufacturer exact dimensions and limits of required work on concrete ringwall.
2. This Std. Dwg. is based on a 16" dia overflow pipe. Larger or smaller pipes will require appropriate resizing of affected facilities.

APPROVED BY:
GSWC STANDARDS COMMITTEE

Alison Sweet

EDC MANAGER

6/15/26
DATE



Golden State
Water Company

A Subsidiary of American States Water Company

TITLE:

**LARGE ACCESS MANWAY
WITH CLEAN-OUT**

SCALE:	DATE:	REV	STANDARD DWG NO.
NONE	04/20/26	2026	T-5

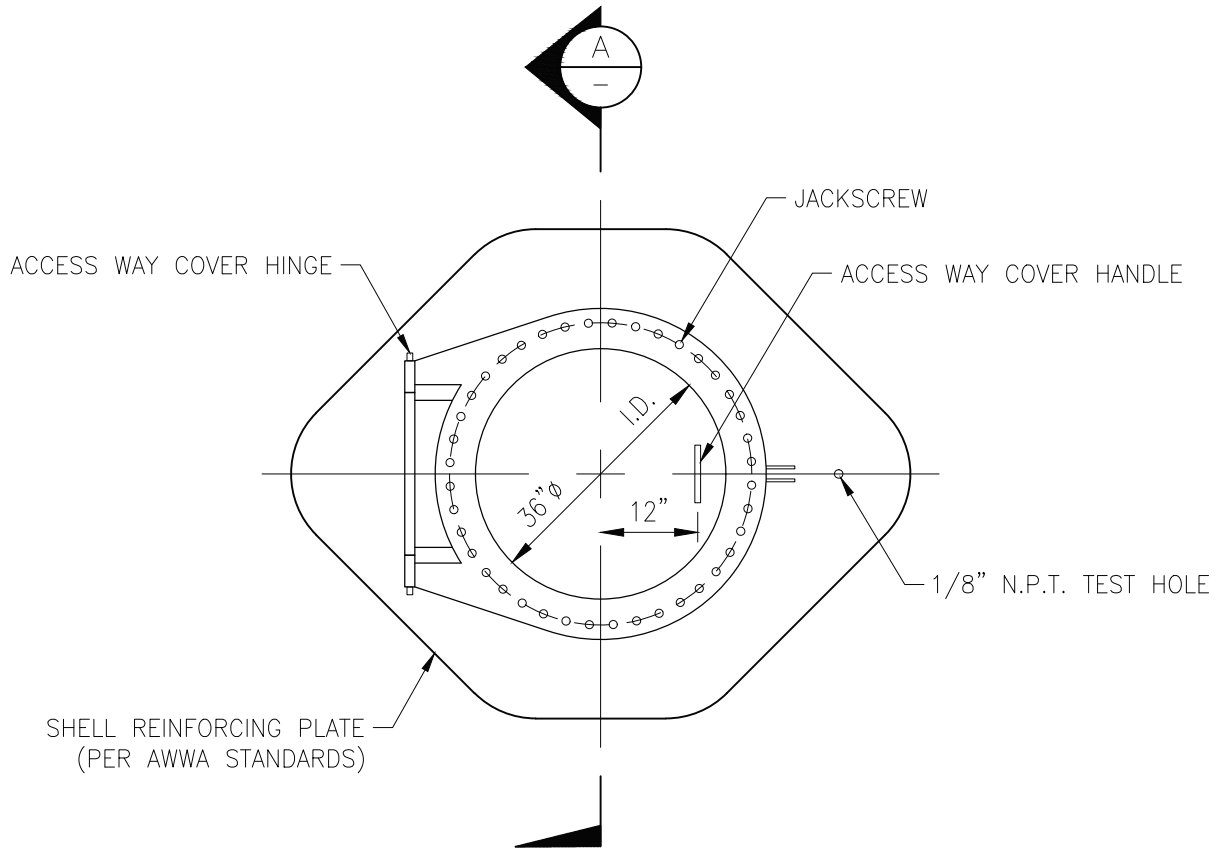

PLAN

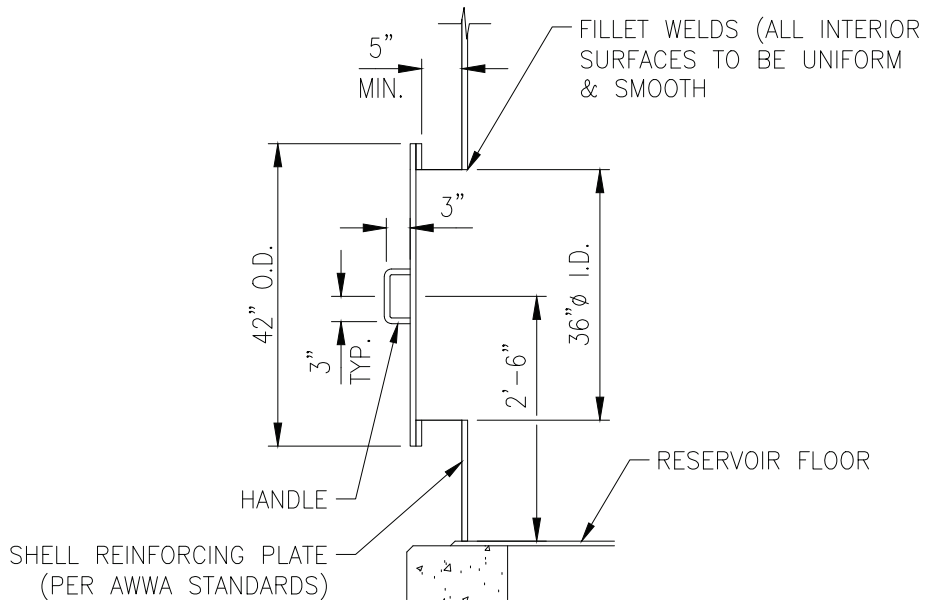

SECTION A

APPROVED BY:
GSWC STANDARDS COMMITTEE

Alison Sweet

EDC MANAGER

6/15/26
DATE



Golden State
Water Company

A Subsidiary of American States Water Company

TITLE:

**36-INCH ACCESS WAY
AND SECTION**

SCALE:
NONE

DATE:
07/31/23

REV
2024

STANDARD DWG NO.
T-7

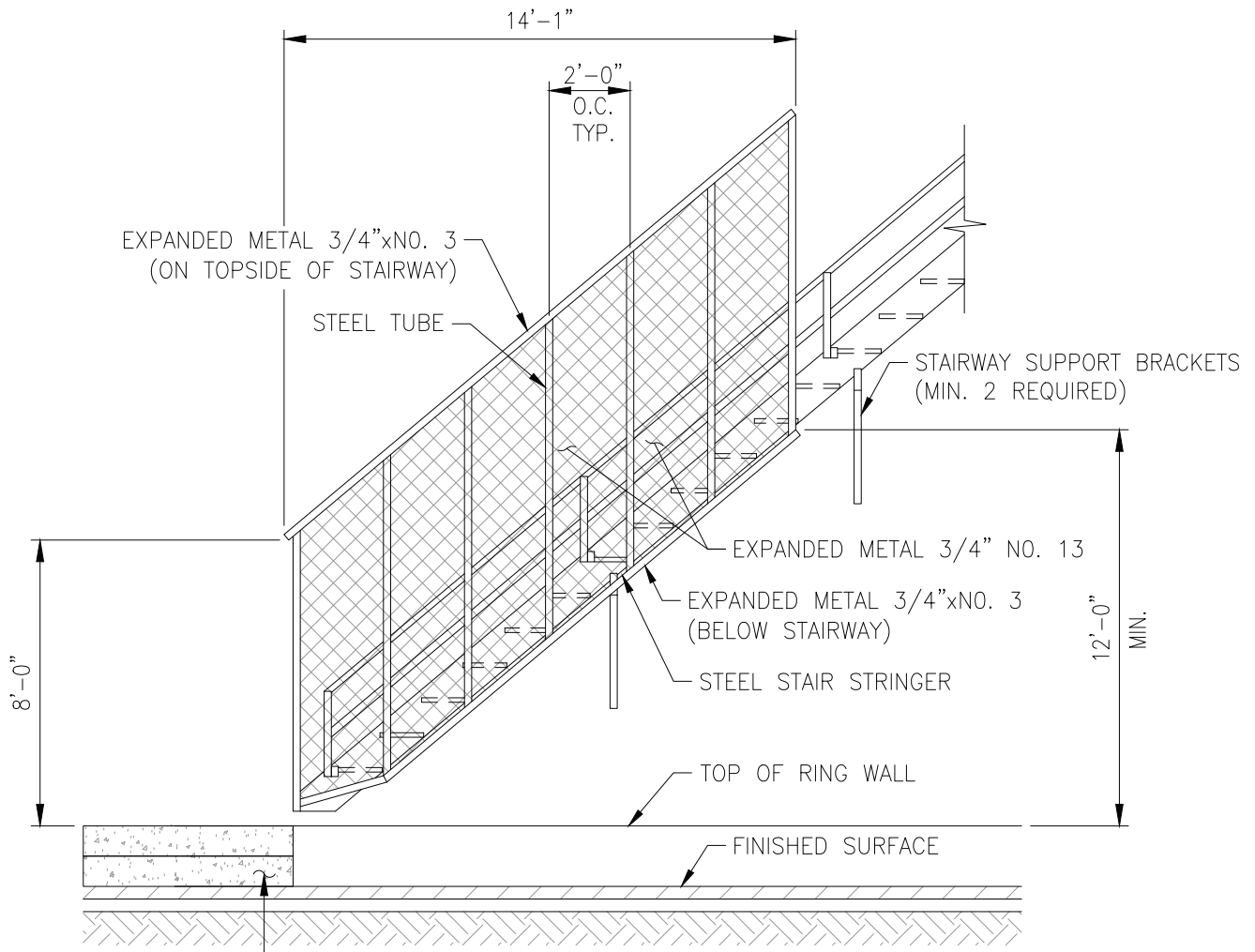

ANTI-CLIMB STAIRWAT CAGE (1)
N.T.S.

CONSTRUCT 2'-4"W x 4'-10" LONG CONCRETE PAD WITH 6" RISE x 10" RUN STEPS. NUMBER OF STEPS DEPENDS ON VERTICAL DISTANCE BETWEEN BOTTOM OF LADDER AND FINISHED PAVEMENT

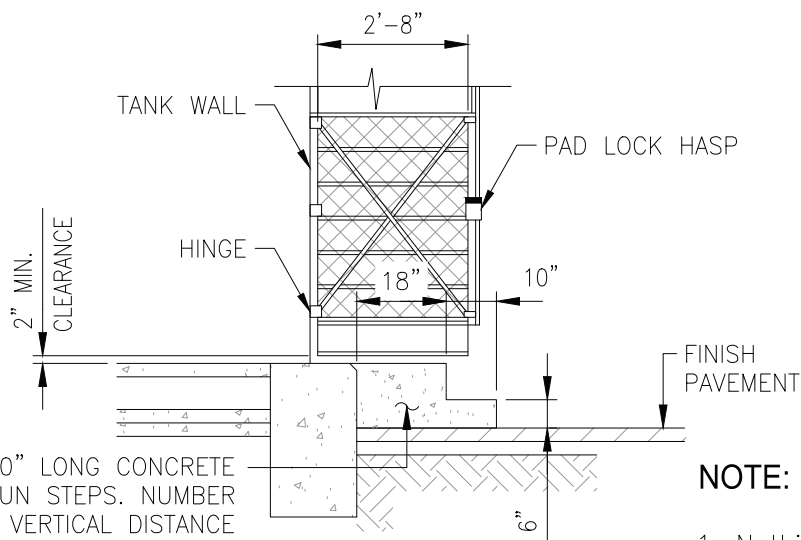

ANTI-CLIMB STAIRWAT GATE (2)
N.T.S.

CONSTRUCT 2'-4"W x 4'-10" LONG CONCRETE PAD WITH 6" RISE x 10" RUN STEPS. NUMBER OF STEPS DEPENDS ON VERTICAL DISTANCE BETWEEN BOTTOM OF LADDER AND FINISHED PAVEMENT

NOTE:
1. Nothing to be installed under stair cage that could be used to assist climbing efforts.

APPROVED BY:
GSWC STANDARDS COMMITTEE
Alison Sweet
EDC MANAGER
6/15/26
DATE



TITLE: STAIRWAY & ANTI-CLIMB CAGE			
SCALE: NONE	DATE: 07/31/23	REV: 2024	STANDARD DWG NO. T-8

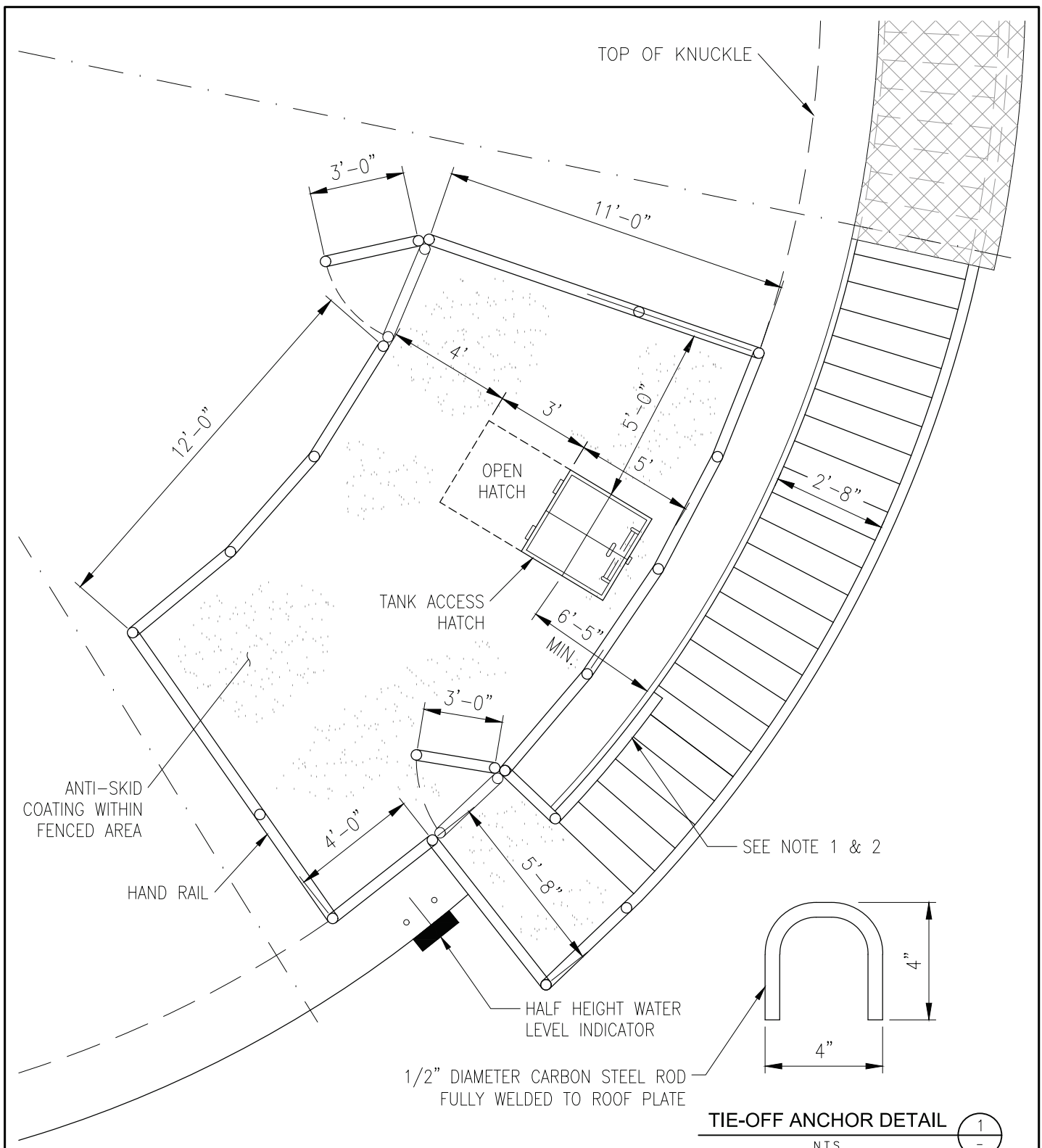

NOTES:

1. Construct handrail against tank from top of platform to 1 foot below bottom of knuckle.
2. Handrail to extend 1-1/2" min. away from the tank shell at all locations.
3. Locate tie-off anchors 90° apart around center vent.
4. Construct 4" high toe kick plate under all handrail. Leave 1/4" gap at bottom for drainage.

APPROVED BY:
GSWC STANDARDS COMMITTEE

Alison Sweet

EDC MANAGER

6/15/26
DATE



Golden State
Water Company

A Subsidiary of American States Water Company

TITLE:

TANK ROOF WORKING AREA

SCALE:
NONE

DATE:
07/31/23

REV
2024

STANDARD DWG NO.
T-9

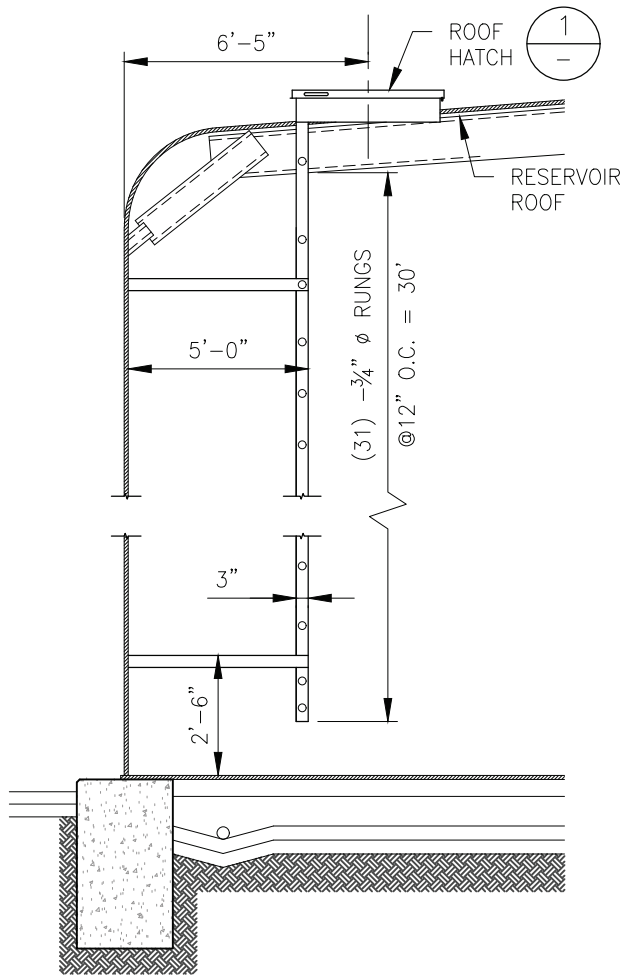

NOTES:

1. Ladder, brackets, & hardware shall be type 316 stainless steel.
2. Carbon steel brackets shall be welded to tank shell and bolted to ladder.
3. Ladder shall be equipped with type 316 stainless steel saf-t-climb fall prevention system.
4. All dissimilar metals shall be electrically isolated from each other.
5. A rubberized water proof gasket shall be installed on the interior of the hatch that prevents dust and dirt from entering the tank.
6. All steel plate for roof hatch and neck shall be $\frac{3}{8}$ " thick min.

INTERNAL LADDER
N.T.S.

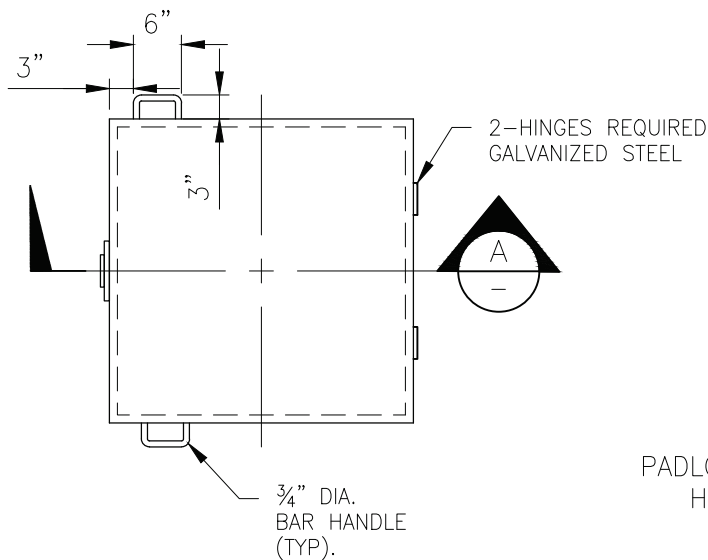

1 36" HINGED ROOF HATCH
N.T.S.

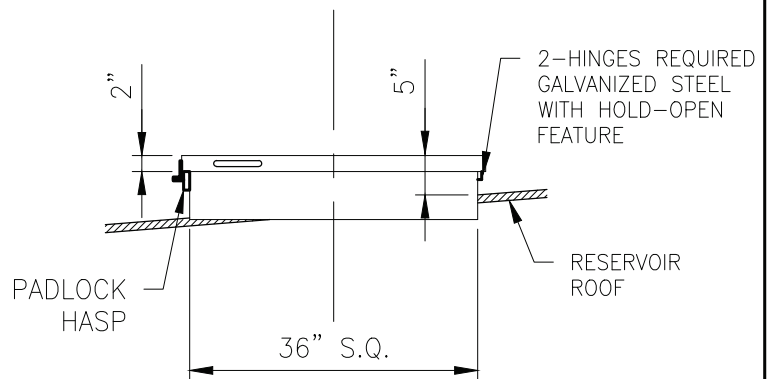

A ROOF HATCH SECTION
N.T.S.

APPROVED BY:
GSWC STANDARDS COMMITTEE

Alison Sweet

EDC MANAGER

6/15/26
DATE



Golden State
Water Company

A Subsidiary of American States Water Company

TITLE:

ROOF HATCH AND
INTERIOR LADDER

SCALE:	DATE:	REV	STANDARD DWG NO.
NONE	07/31/23	2024	T-10

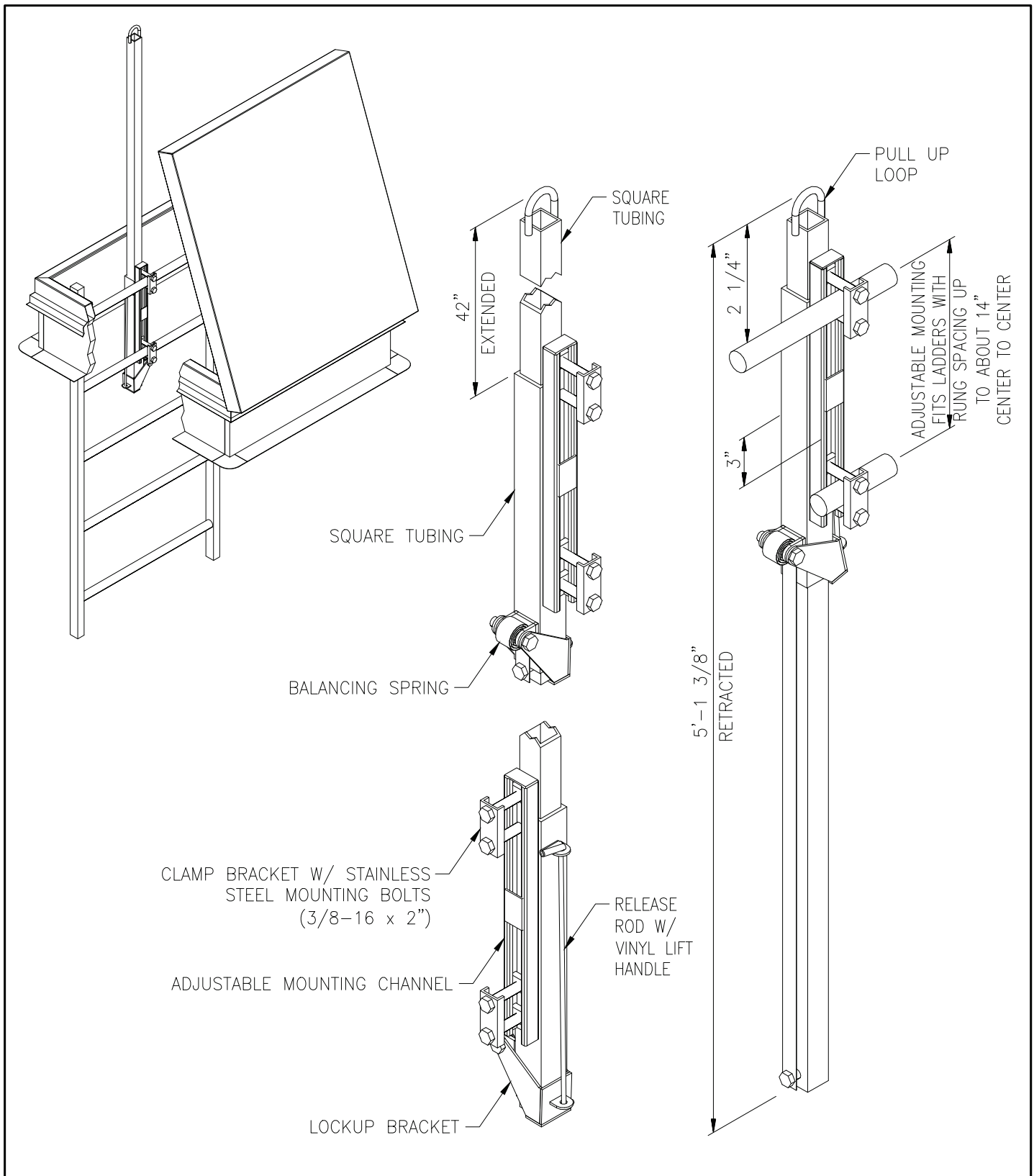

NOTE:

CLAMP BRACKET MAY BE REVERSED TO ACCOMMODATE RUNG SIZES OF 3/4" TO 1 1/4" WITH STANDARD 2" BOLTS FURNISHED. LARGER RUNGS WILL REQUIRE LONGER BOLTS.

APPROVED BY:
 GSWC STANDARDS COMMITTEE
Alison Sweet
 EDC MANAGER
 6/15/26
 DATE



TITLE: INTERIOR LADDER SAFETY POST			
SCALE: NONE	DATE: 07/31/23	REV 2024	STANDARD DWG NO. T-11

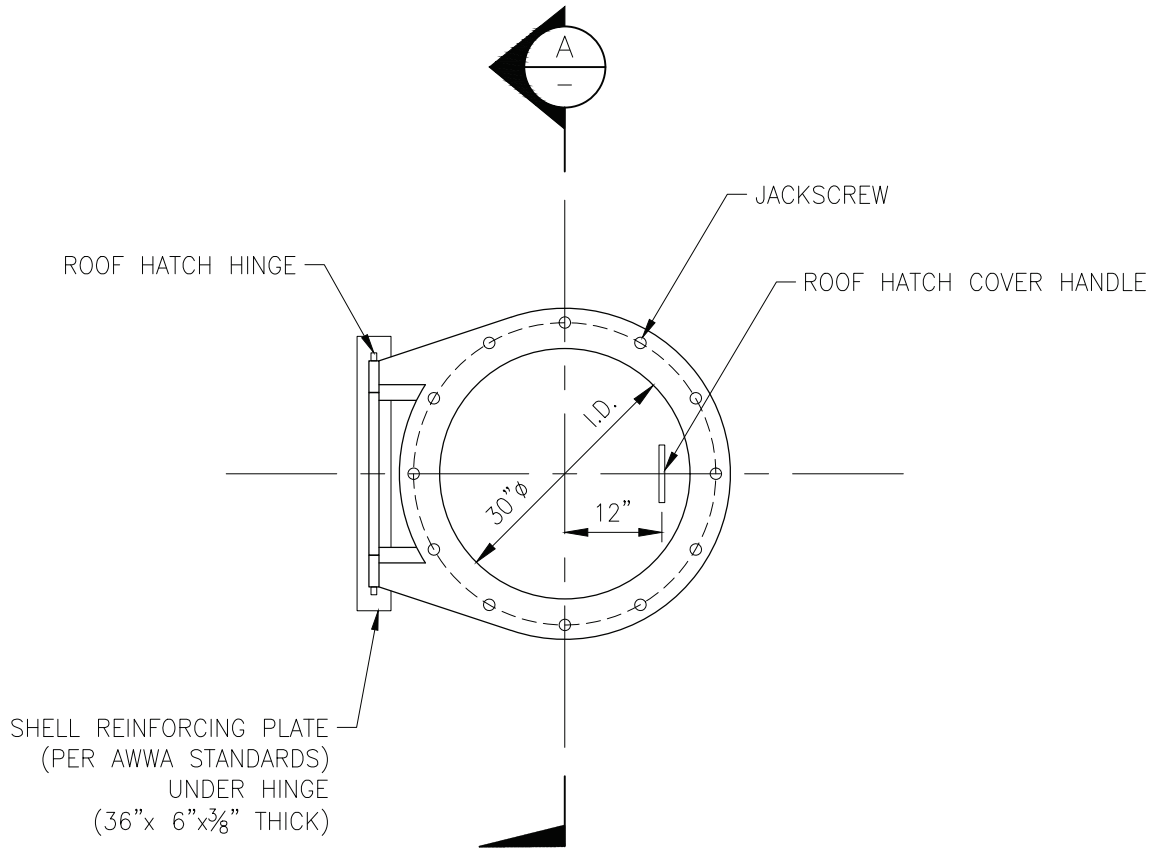

PLAN

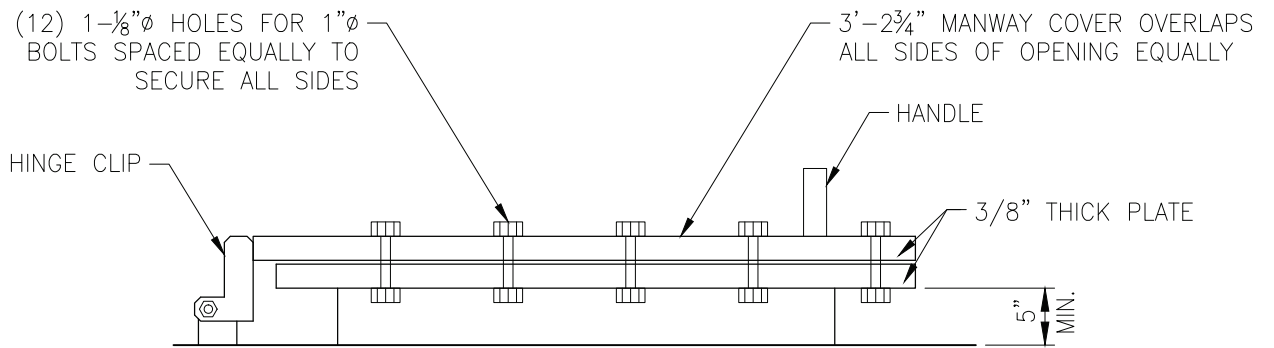

NOTE: Full faced gasket shall be installed between the roof hatch cover and shell flange.

SECTION A

APPROVED BY:
GSWC STANDARDS COMMITTEE

Alison Sweet

EDC MANAGER

6/15/26
DATE



Golden State
Water Company

A Subsidiary of American States Water Company

TITLE:

SEALED FLANGED
ROOF HATCH

SCALE:
NONE

DATE:
07/31/23

REV
2024

STANDARD DWG NO.
T-12

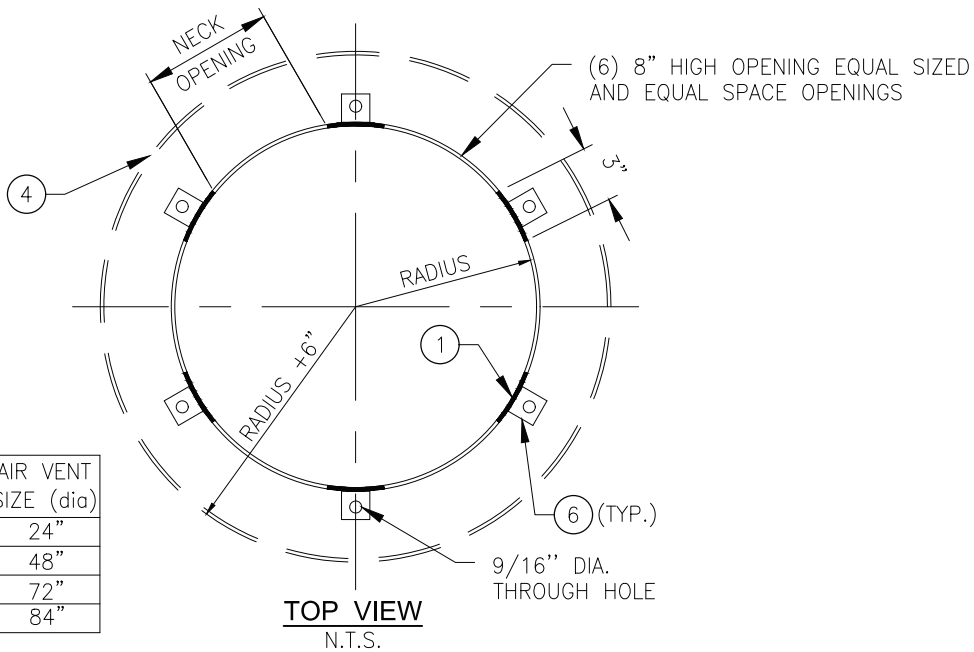

SIZE (MG)	TANK DIA (ft)	AIR VENT SIZE (dia)
less than 0.5	60	24"
0.5 to 2.0	68-113	48"
2.1 to 4.0	113-159	72"
larger than 4.0	160+	84"

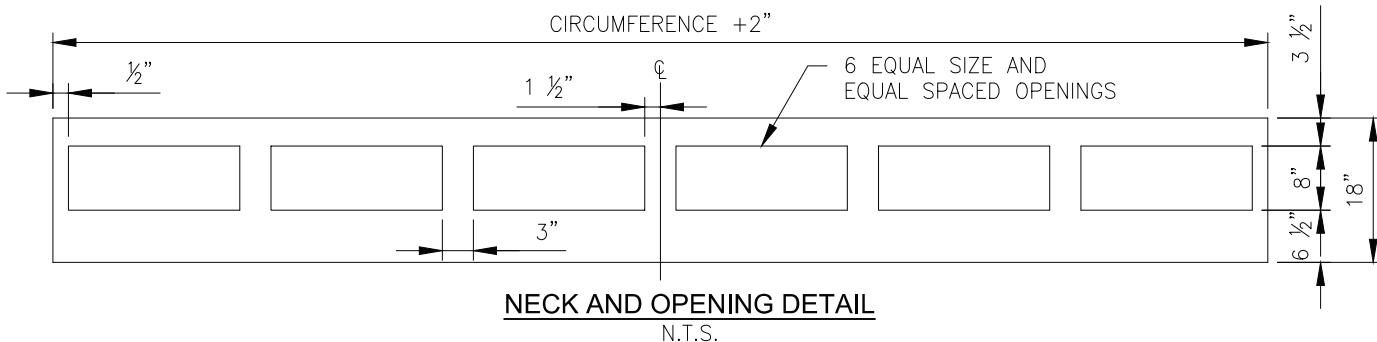
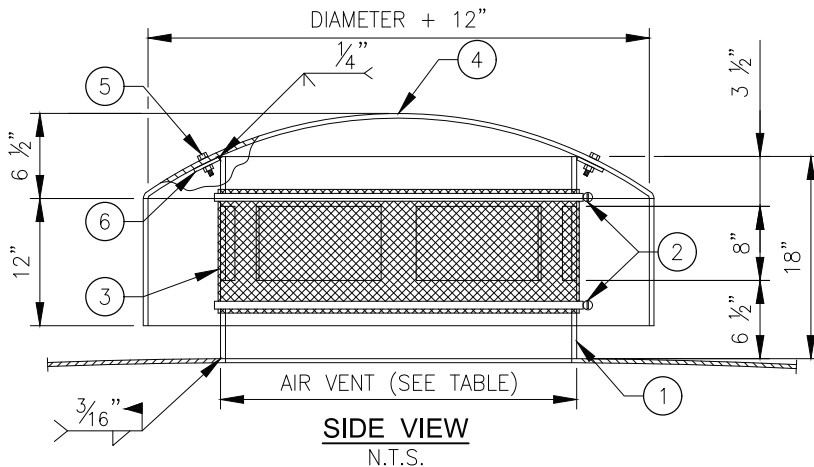

MATERIALS LIST		
ITEM	DESCRIPTION	QTY
1	NECK: 1/4" THK. x 18" WIDE x CIRCUMFERENCE + 2"	A36 1
2	1/2" WORM DRIVE BAND	316 S.S. 2
3	20 MESH INSECT SCREEN ON INSIDE AND 2x2 MESH ON OUTSIDE	316 S.S. 1
4	3/16" THK. DISHED HEAD	A36 1
5	BOLTS WITH NUT, 1/2" DIA., 1 1/4" LONG	HDG 6
6	PLATE: 1/4" x 2" x 2" W/ 9/16" DIA. THROUGH HOLE	A36 6

APPROVED BY:
GSWC STANDARDS COMMITTEE

Alison Sweet

EDC MANAGER

6/15/26
DATE



Golden State
Water Company

A Subsidiary of American States Water Company

TITLE:

CENTER ROOF VENT

SCALE:	DATE:	REV	STANDARD DWG NO.
NONE	07/31/23	2024	T-13

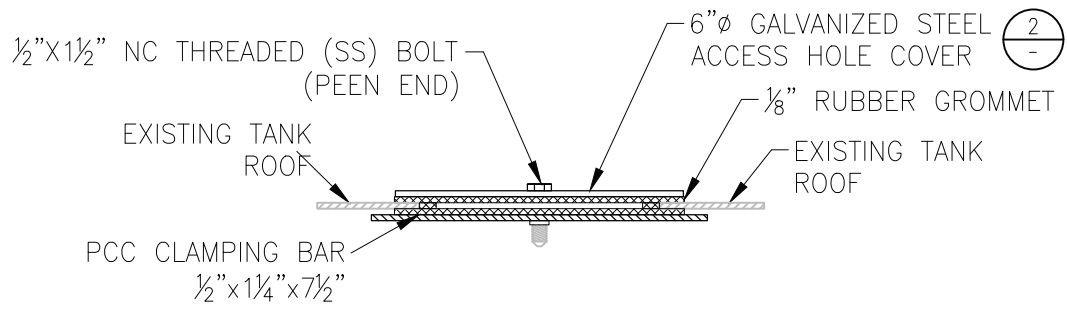

TANK ROOF CP AND HOLE COVER AND RUBBER GROMMET 1
-
N.T.S.

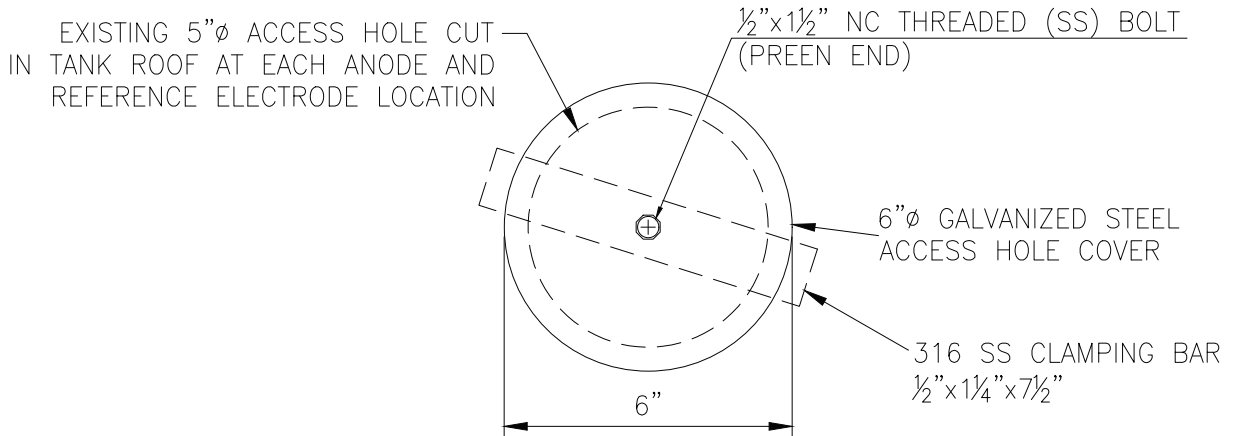

6" GALVANIZED STEEL ACCESS HOLE COVER 2
-
N.T.S.

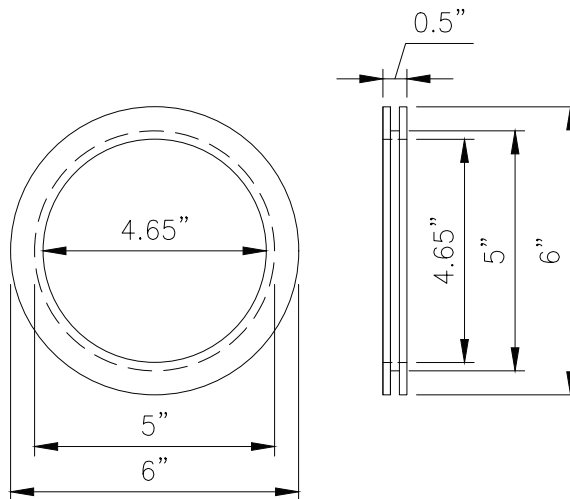

CP AND HOLE COVER AND RUBBER GROMMET DETAIL 3
-
N.T.S.

APPROVED BY:
GSWC STANDARDS COMMITTEE

Alison Sweet

EDC MANAGER

6/15/26
DATE



Golden State
Water Company

A Subsidiary of American States Water Company

TITLE:

TANK ROOF CP HAND HOLE COVER

SCALE:
NONE

DATE:
07/31/23

REV
2024

STANDARD DWG NO.
T-14

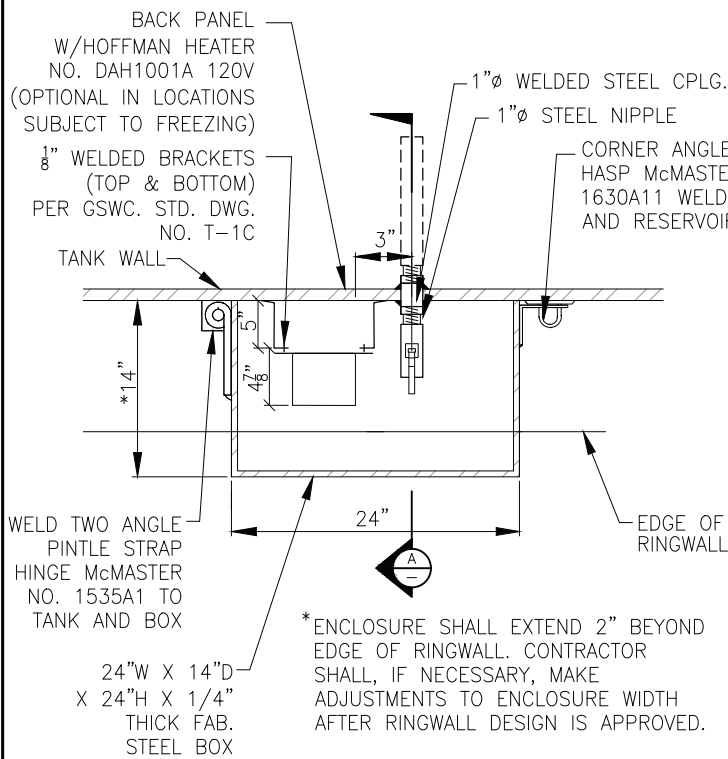

ENCLOSURE DETAIL

N.T.S.

(LEVEL TRANSMITTER TO BE INSTALLED BY OTHERS)

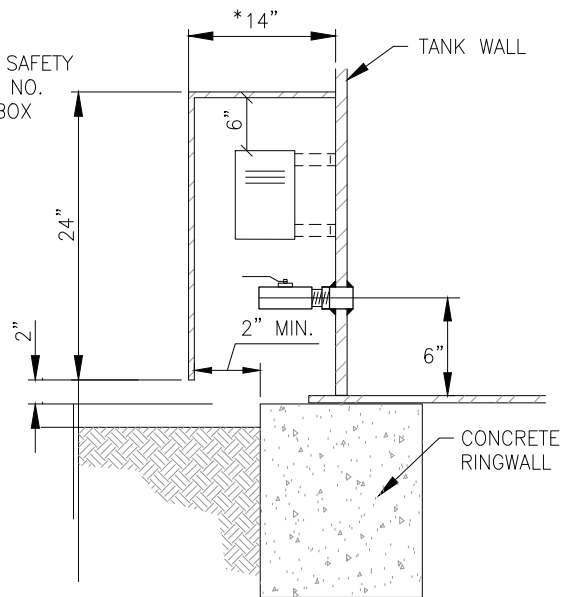

SECTION A

N.T.S.

(SHOWING SENSING LINE)

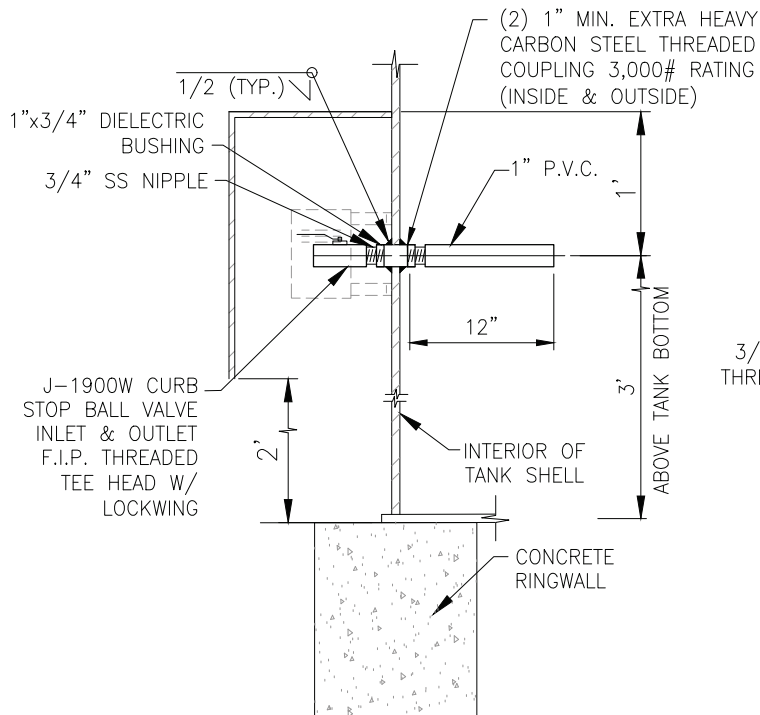

WATER SAMPLING CONNECTION

N.T.S.

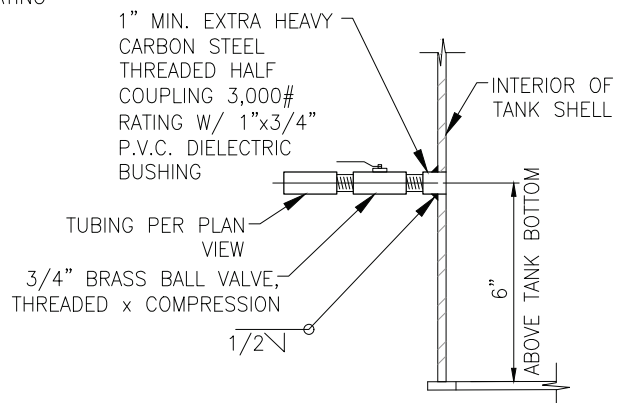

SENSING LINE CONNECTION

N.T.S.

NOTES:

1. Sensing line for altitude valve control and water level depth sensing shall be 6" above the tank bottom.

APPROVED BY:
GSWC STANDARDS COMMITTEE

Alison Sweet

EDC MANAGER

6/15/26
DATE



Golden State
Water Company

A Subsidiary of American States Water Company

TITLE:

**WATER SAMPLING CONNECTION AND
SENSING LINE CONNECTION**

SCALE:
NONE

DATE:
07/31/23

REV
2024

STANDARD DWG NO.
T-15A

CONSTRUCTION NOTES:

- ① ADAPTER 90 BRS 1/2" CMPX 1/2" MPT.
- ② ADAPTER SAMPLE PORT WELDMENT 316SS.
- ③ BOLT 1/4" x 1" HDG GR A325 WITH INSULATING WASHER BETWEEN BOLT HEAD AND S.S. CLAMP.
- ④ BOLT, HEX; HVY; 0.625 DIA; UNC; 3.25" LG; CS; RH.
- ⑤ FLANGE 2" x 1/2" RD 316SS NPT S40 I.
- ⑥ CLAMP 1/2" SS TUBING W/RL 1/4" BN.
- ⑦ GASKET FLG 2 RED RUBBER RING 0.125 THICK 150# RING.
- ⑧ NOZZLE 3/4" 316SS L 1" EFF x 0.010 SLOT FNPT PER DRAWING SAMPLE SCREEN.DWG.
- ⑨ NUT;HH;0.25" DIAMETER GALVANIZED DH (INCLUDED W/ BOLT).
- ⑩ NUT;HH;0.75" DIAMETER; STEEL; GALVANIZED DH (INCLUDED W/BOLT).
- ⑪ TUBE;RND;SS;316/316L;0.5" 0.035";RND.
- ⑫ TUBE;RND;SS;316/316L;0.5" 0.035";RND.
- ⑬ VALVE; BALL FULL PT 0.5" 316SS BDY NPT:
- ⑭ WASHER 1/4" HOT DIPPED GALVANIZED FLAT.
- ⑮ WASHER;FLAT;0.625";CS; GALVANIZED.
- ⑯ WASHER;SPLIT;0.25";OD;STEEL;GALVANIZED.
- ⑰ WELDED BRACKET AND STRUT (8" LONG x 2" WIDE x 1/4" THICK) SIMILAR TO DETAIL (LOCATED 4' VERTICAL O.C.)

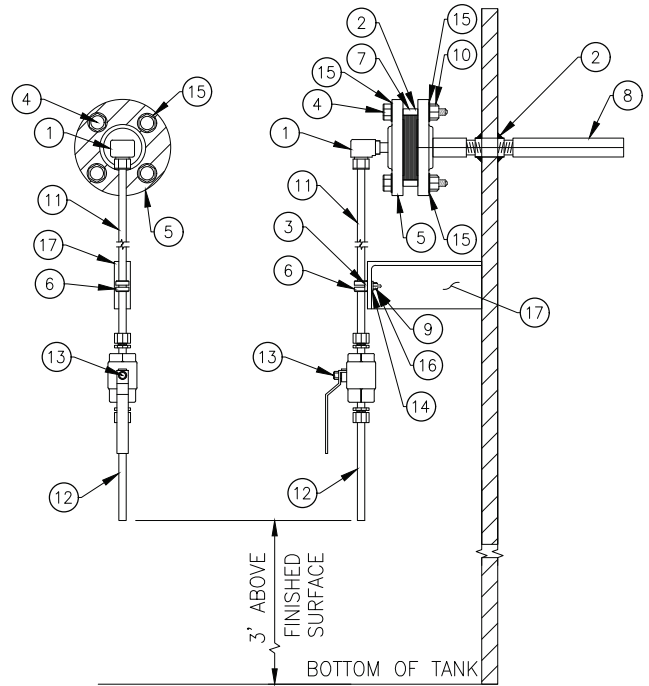

TANK SAMPLE PORT
N.T.S.

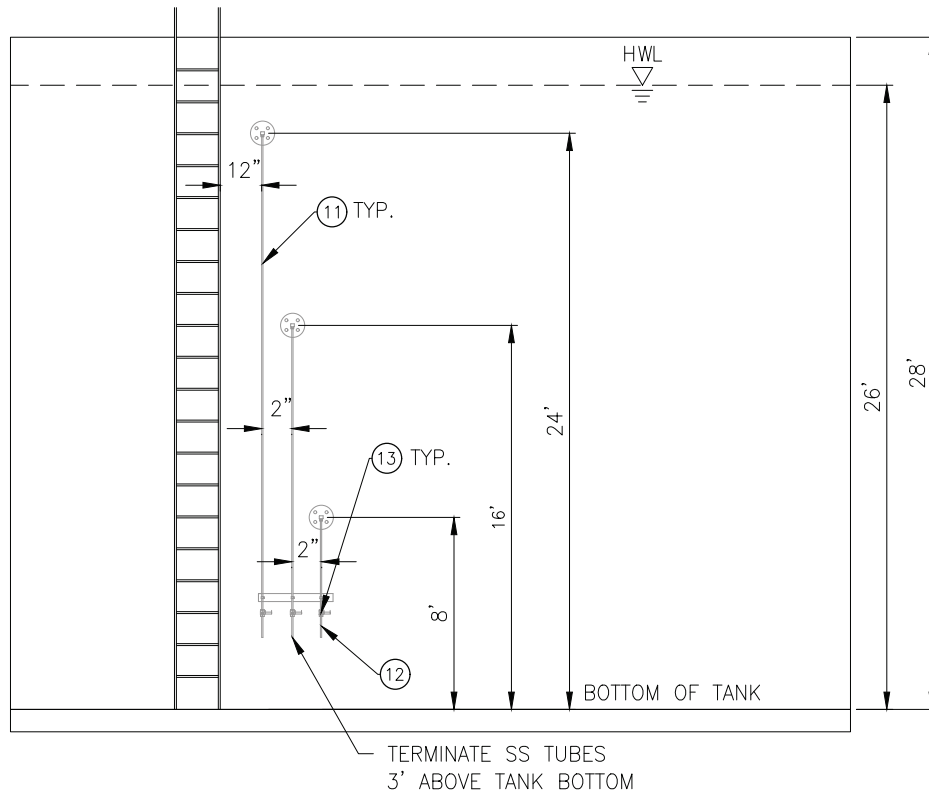

LOCATION OF TANK SAMPLE PORTS ON TANK SHELL
(HORIZONTAL DISTANCE BETWEEN S.S. TUBES)
N.T.S.

APPROVED BY:
GSWC STANDARDS COMMITTEE

Alison Sweet

EDC MANAGER

6/15/26
DATE



Golden State
Water Company

A Subsidiary of American States Water Company

TITLE:

TANK MULTIPLE SAMPLE PORTS

SCALE:
NONE

DATE:
07/31/23

REV
2024

STANDARD DWG NO.
T-15B

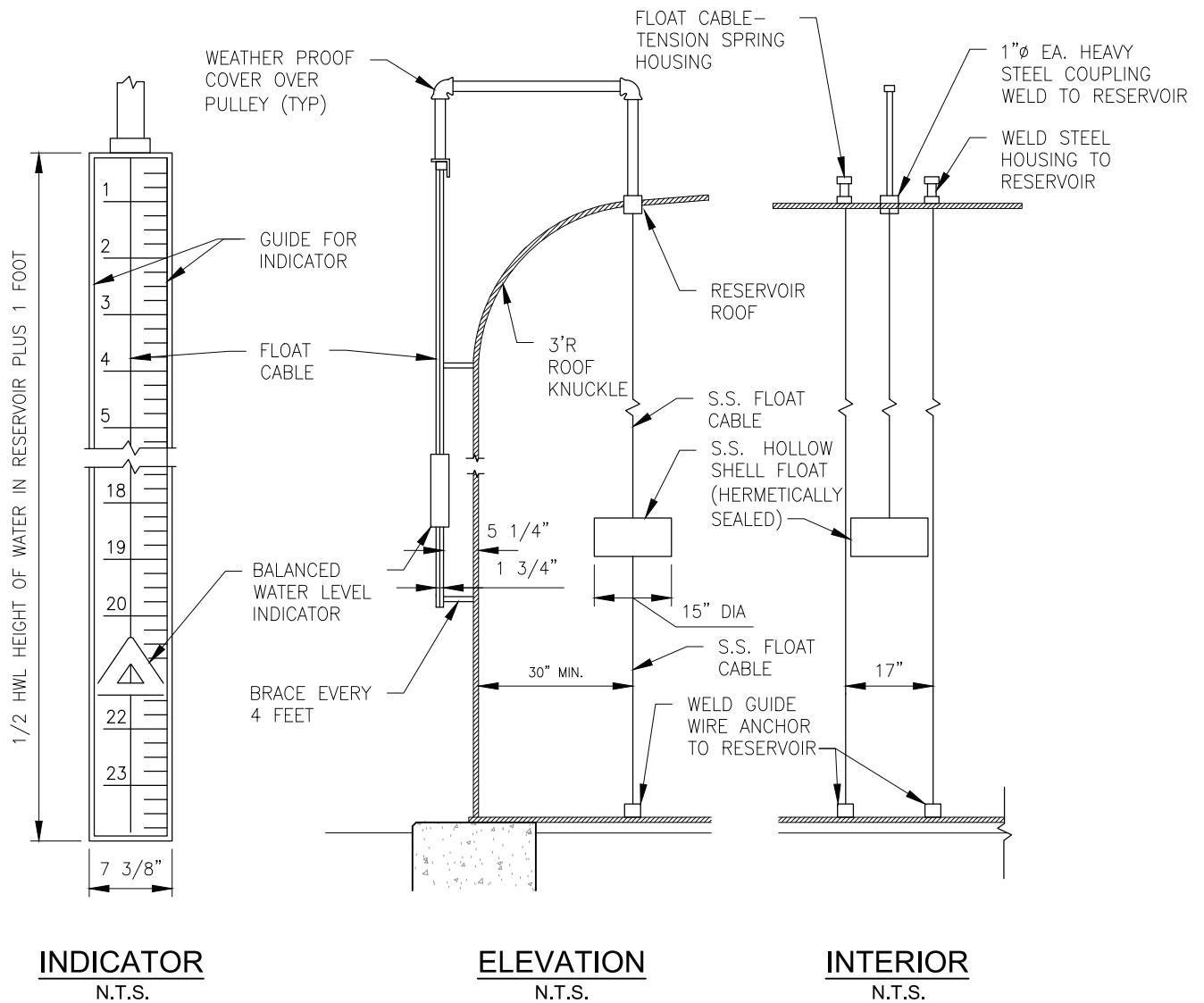

HALF HEIGHT WATER LEVEL INDICATOR
N.T.S.

NOTES:

1. See plans for location of level indicator on tank.
2. Locate level indicator as close to roof hatch as possible for maintenance access.

APPROVED BY:
GSWC STANDARDS COMMITTEE

Alison Sweet

EDC MANAGER

6/15/26
DATE



Golden State
Water Company

A Subsidiary of American States Water Company

TITLE:

**HALF HEIGHT WATER
LEVEL INDICATOR**

SCALE:	DATE:	REV	STANDARD DWG NO.
NONE	07/31/23	2024	T-16

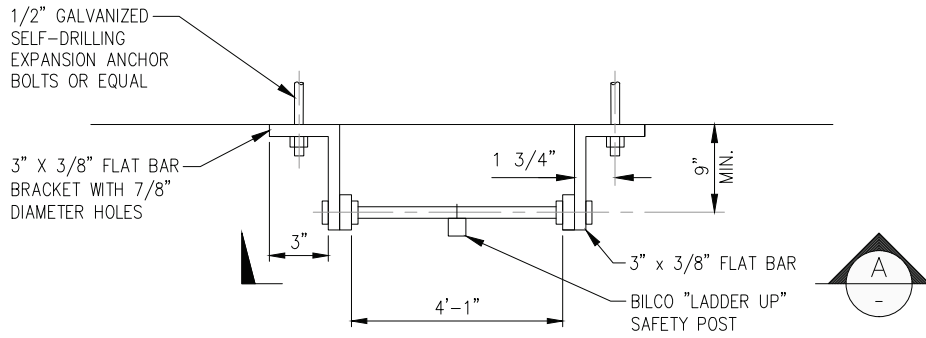

LADDER TIE-DOWN TOP VIEW 1
N.T.S.

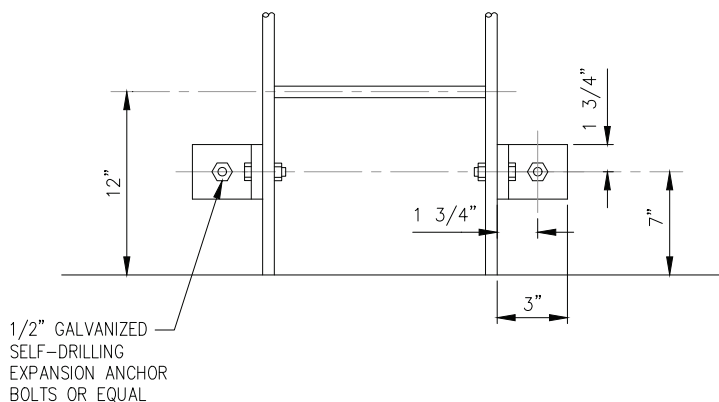

SECTION A
N.T.S.

NOTE:

1. Ladder and brackets to be carbon steel that is galvanized after fabrication.

APPROVED BY:
GSWC STANDARDS COMMITTEE
Alison Sweet
EDC MANAGER
6/15/26
DATE



TITLE: ALTITUDE VAULT LADDER TIE-DOWN DETAIL			
SCALE: NONE	DATE: 07/31/23	REV 2024	STANDARD DWG NO. T-18

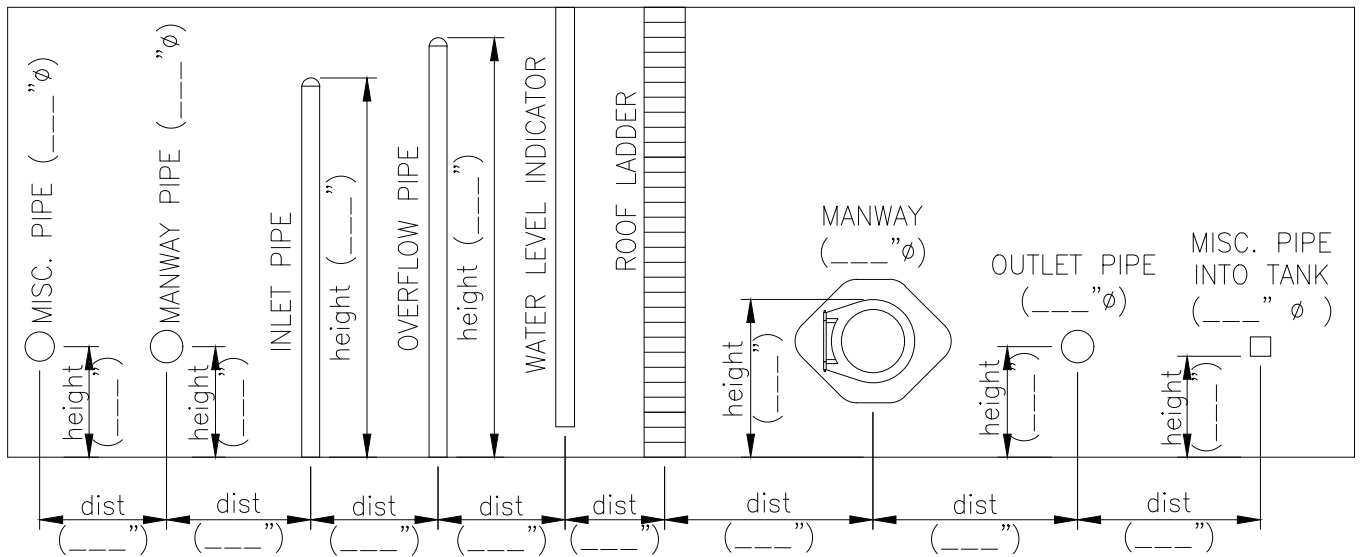
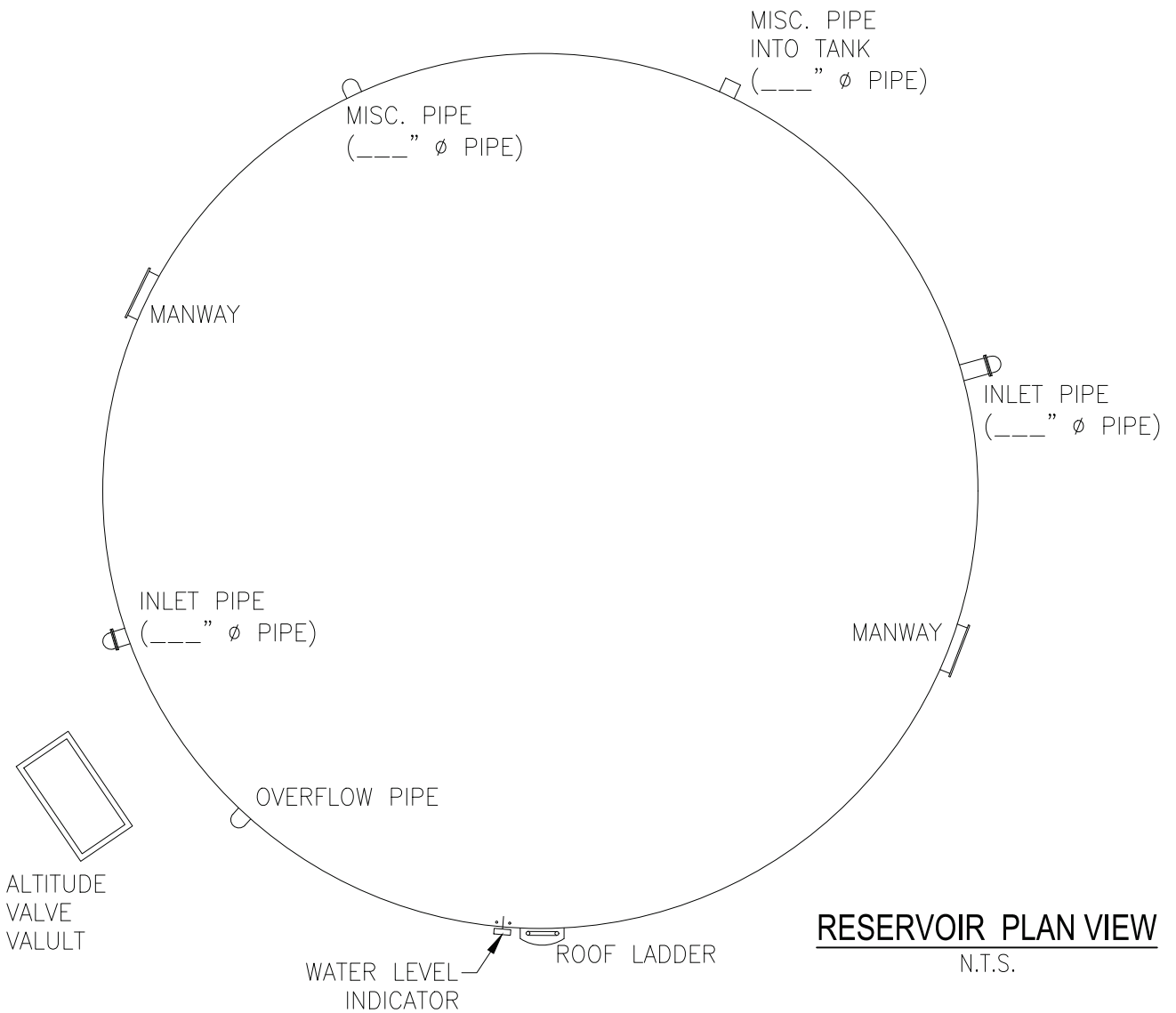

APPROVED BY:
GSWC STANDARDS COMMITTEE

Alison Sweet

EDC MANAGER

6/15/26
DATE



Golden State
Water Company

A Subsidiary of American States Water Company

TITLE:

EXAMPLE OF
TYPICAL TANK SURVEY
APPURTENANCE LOCATIONS

SCALE:
NONE

DATE:
07/31/23

REV
2024

STANDARD DWG NO.
T-19A

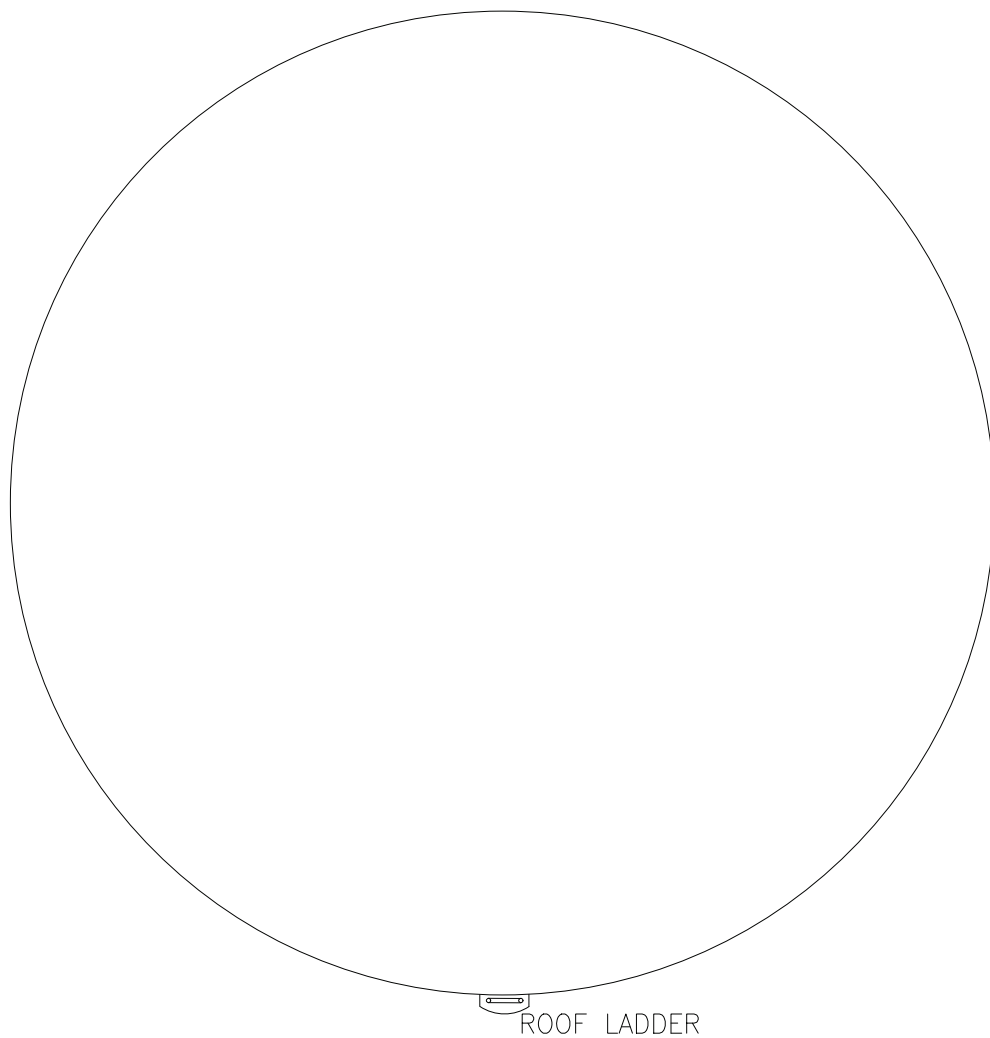

ROOF LADDER



APPROVED BY:
GSWC STANDARDS COMMITTEE

Alison Sweet

EDC MANAGER

6/15/26
DATE



Golden State
Water Company

A Subsidiary of American States Water Company

TITLE:

BLANK
TYPICAL TANK SURVEY
APPURTENANCE LOCATIONS

SCALE:	DATE:	REV	STANDARD DWG NO.
NONE	07/31/23	2024	T-19B